



# Dealers Industrial Equipment

No.:

Date: 29-SEP-2016

Customer :

## TECHNICAL PROPOSAL

### Three-phase induction motor - Squirrel cage rotor

Product line : W40 - Open Induction Motors – NEMA Premium Efficiency

Catalog Number : 35018OT3G447/9T-W40

List Price : \$25,174

#### Notes:

Downloaded from <http://dealerselectric.com>

Generated for Model #35018OT3G447/9T-W40

Performed by:

Checked:



# Dealers Industrial Equipment

No.:

Date: 29-SEP-2016

## DATA SHEET Three-phase induction motor - Squirrel cage rotor

Customer :  
 Product line : W40 - Open Induction Motors – NEMA Premium Efficiency

Frame : 447/9T  
 Output : 350 HP  
 Frequency : 60 Hz  
 Poles : 4  
 Full load speed : 1780 rpm  
 Slip : 1.11 %  
 Voltage : 460 V  
 Rated current : 396 A  
 Locked rotor current : 2610 A  
 Locked rotor current (I<sub>L</sub>/I<sub>n</sub>) : 6.6  
 No-load current : 125 A  
 Full load torque : 1019 lb.ft  
 Locked rotor torque : 200 %  
 Breakdown torque : 230 %  
 Design : B  
 Insulation class : F  
 Temperature rise : 80 K  
 Locked rotor time : 10 s (hot)  
 Service factor : 1.15  
 Duty cycle : S1  
 Ambient temperature : -20°C - +40°C  
 Altitude : 1000 m  
 Degree of Protection : IP23  
 Approximate weight : 2315 lb  
 Moment of inertia : 66.055 sq.ft.lb  
 Noise level : 77 dB(A)

	D.E.	N.D.E.
Bearings	6319 C3	6314 C3
Regreasing interval	20000 h	20000 h
Grease amount	45 g	27 g

Load	Power factor	Efficiency (%)
100%	0.86	95.8
75%	0.83	95.8
50%	0.76	95.8

Notes:  
 Downloaded from <http://dealerselectric.com>  
 Generated for Model #35018OT3G447/9T-W40

Performed by

Checked



# Dealers Industrial Equipment

No.:

Date: 29-SEP-2016

## PERFORMANCE CURVES RELATED TO RATED OUTPUT

Three-phase induction motor - Squirrel cage rotor

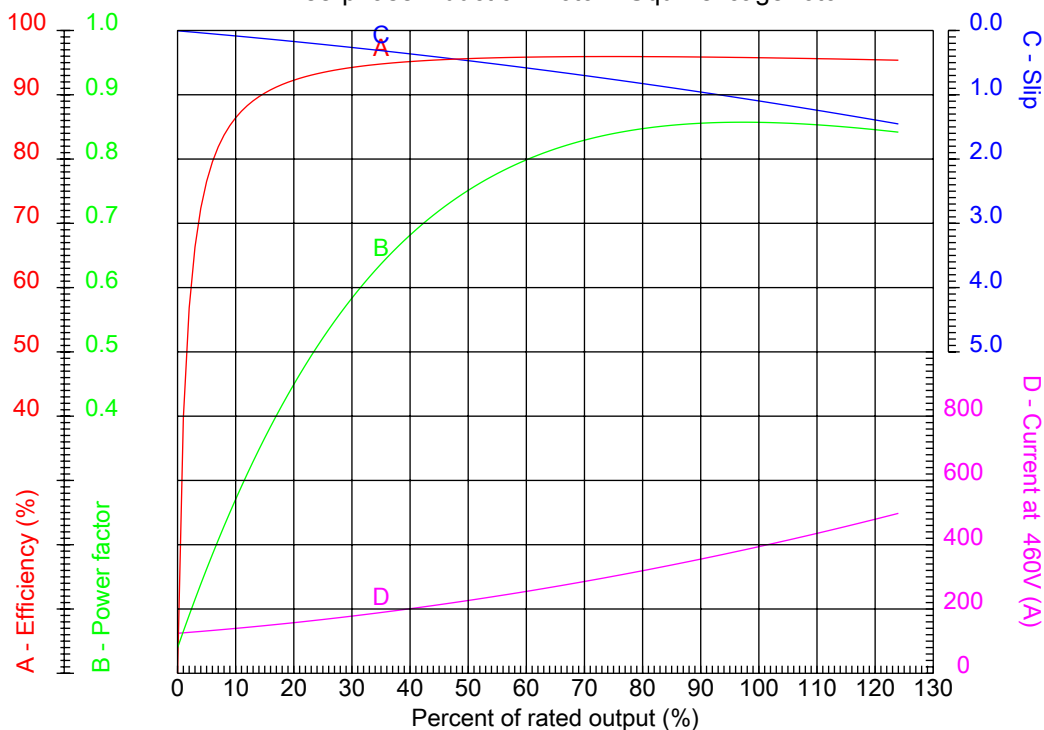

Customer :  
Product line : W40 - Open Induction Motors - NEMA Premium Efficiency

Frame : 447/9T	Locked rotor current (I <sub>L</sub> /I <sub>n</sub> ) : 6.6
Output : 350 HP	Duty cycle : S1
Frequency : 60 Hz	Service factor : 1.15
Full load speed : 1780 rpm	Design : B
Voltage : 460 V	Locked rotor torque : 200 %
Rated current : 396 A	Breakdown torque : 230 %
Insulation class : F	

Notes:  
Downloaded from <http://dealerselectric.com>  
Generated for Model #35018OT3G447/9T-W40

Performed by

Checked



# Dealers Industrial Equipment

No.:

Date: 29-SEP-2016

## CHARACTERISTIC CURVES RELATED TO SPEED

Three-phase induction motor - Squirrel cage rotor

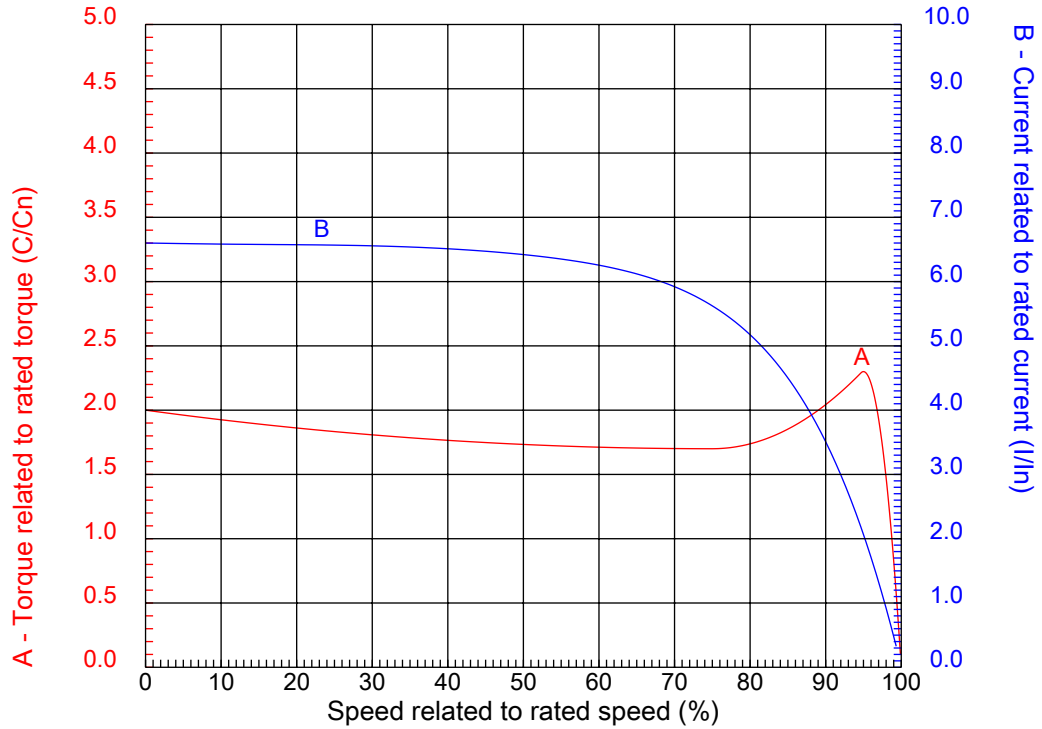

Customer :  
Product line : W40 - Open Induction Motors – NEMA Premium Efficiency

Frame	: 447/9T	Locked rotor current (I <sub>l</sub> /I <sub>n</sub> )	: 6.6
Output	: 350 HP	Duty cycle	: S1
Frequency	: 60 Hz	Service factor	: 1.15
Full load speed	: 1780 rpm	Design	: B
Voltage	: 460 V	Locked rotor torque	: 200 %
Rated current	: 396 A	Breakdown torque	: 230 %
Insulation class	: F		

Notes:  
Downloaded from <http://dealerselectric.com>  
Generated for Model #35018OT3G447/9T-W40

Performed by

Checked

1 2 3 4 5 6 7 8

A

B

C

D

E

F

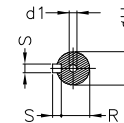
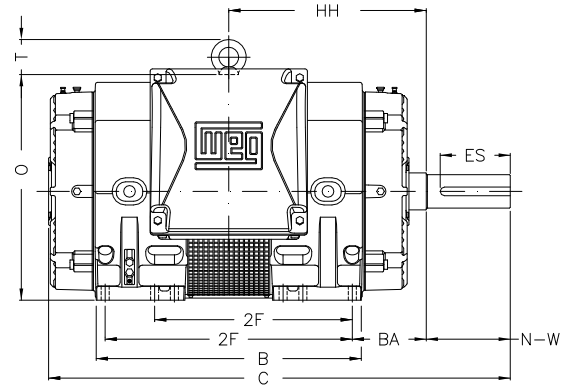
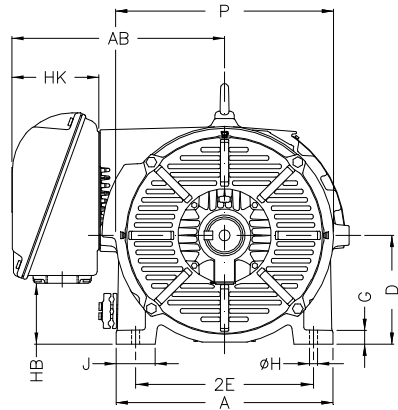
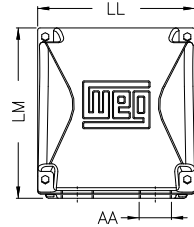

Notes: Downloaded from <http://dealerselectric.com>  
Generated for Model #35018OT3G447/9T-W40

2E 18.000	J 3.983	A 21.929	P 25.197	AB 21.505
2F 20.000/25.000	K 8.971	B 26.820	FK 8.971	EV 0.910
BA 7.480	U 3.375	d1 DUNC 7/8"-9	N-W 8.500	ES 7.087
S 0.875	R 2.882	depth 0.875	D 11.000	G 1.397
O 22.811	T 3.543	HH 19.980	H 0.810	C 46.709
AA 2xNPT 3"	DM NPT 3/4"	LL 15.904	LM 17.225	HK 8.907
HB 6.158				

Performed by:

Checked:

Customer:

W40 - Open Induction Motors – NEMA Premium Efficiency

Three-phase induction motor  
Frame 447/9T - IP23

29-SEP-2016

