



Dealers Industrial Equipment

No.:

Date: 28-SEP-2016

Customer :

TECHNICAL PROPOSAL

Three-phase induction motor - Squirrel cage rotor

Product line : W40 - Open Induction Motors – NEMA Premium Efficiency

Catalog Number : 20012OT3G447/9T-W40

List Price : \$23,380

Notes:

Downloaded from <http://dealerselectric.com>

Generated for Model #20012OT3G447/9T-W40

Performed by:

Checked:



Dealers Industrial Equipment

No.:

Date: 28-SEP-2016

DATA SHEET Three-phase induction motor - Squirrel cage rotor

Customer :
 Product line : W40 - Open Induction Motors – NEMA Premium Efficiency

Frame : 447/9T
 Output : 200 HP
 Frequency : 60 Hz
 Poles : 6
 Full load speed : 1185 rpm
 Slip : 1.25 %
 Voltage : 460 V
 Rated current : 241 A
 Locked rotor current : 1400 A
 Locked rotor current (I_L/I_n) : 5.8
 No-load current : 95.0 A
 Full load torque : 874 lb.ft
 Locked rotor torque : 200 %
 Breakdown torque : 220 %
 Design : A
 Insulation class : F
 Temperature rise : 80 K
 Locked rotor time : 18 s (hot)
 Service factor : 1.15
 Duty cycle : S1
 Ambient temperature : -20°C - +40°C
 Altitude : 1000 m
 Degree of Protection : IP23
 Approximate weight : 2205 lb
 Moment of inertia : 98.166 sq.ft.lb
 Noise level : 79 dB(A)

	D.E.	N.D.E.
Bearings	6319 C3	6314 C3
Regreasing interval	20000 h	20000 h
Grease amount	45 g	27 g

Load	Power factor	Efficiency (%)
100%	0.82	95.4
75%	0.78	95.4
50%	0.69	95.0

Notes:
 Downloaded from <http://dealerselectric.com>
 Generated for Model #20012OT3G447/9T-W40

Performed by

Checked



Dealers Industrial Equipment

No.:

Date: 28-SEP-2016

PERFORMANCE CURVES RELATED TO RATED OUTPUT

Three-phase induction motor - Squirrel cage rotor

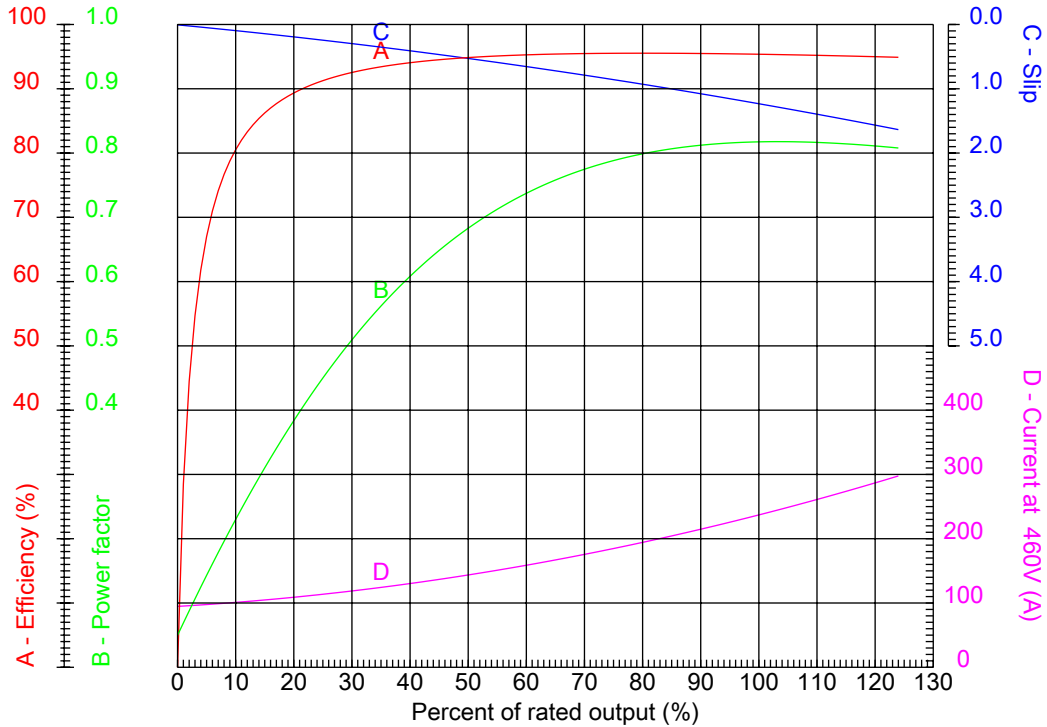

Customer :
 Product line : W40 - Open Induction Motors – NEMA Premium Efficiency

Frame : 447/9T	Locked rotor current (I _L /I _n) : 5.8
Output : 200 HP	Duty cycle : S1
Frequency : 60 Hz	Service factor : 1.15
Full load speed : 1185 rpm	Design : A
Voltage : 460 V	Locked rotor torque : 200 %
Rated current : 241 A	Breakdown torque : 220 %
Insulation class : F	

Notes:
 Downloaded from <http://dealerselectric.com>
 Generated for Model #20012OT3G447/9T-W40

Performed by

Checked



Dealers Industrial Equipment

No.:

Date: 28-SEP-2016

CHARACTERISTIC CURVES RELATED TO SPEED

Three-phase induction motor - Squirrel cage rotor

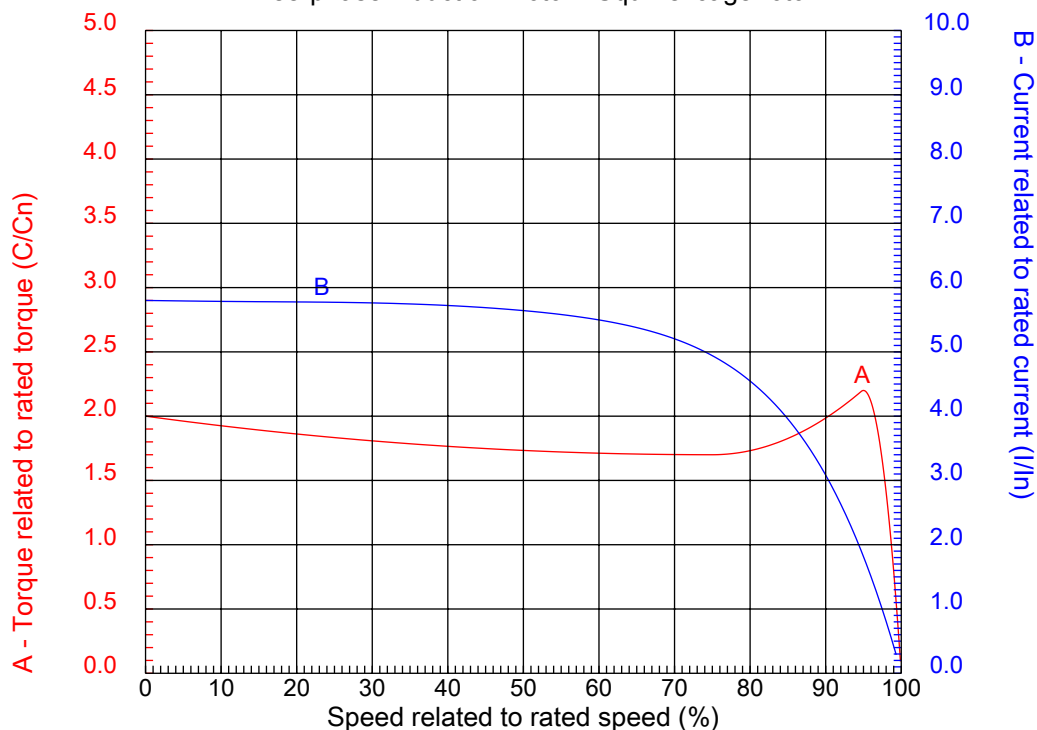

Customer :
Product line : W40 - Open Induction Motors – NEMA Premium Efficiency

Frame	: 447/9T	Locked rotor current (I _l /I _n)	: 5.8
Output	: 200 HP	Duty cycle	: S1
Frequency	: 60 Hz	Service factor	: 1.15
Full load speed	: 1185 rpm	Design	: A
Voltage	: 460 V	Locked rotor torque	: 200 %
Rated current	: 241 A	Breakdown torque	: 220 %
Insulation class	: F		

Notes:
Downloaded from <http://dealerselectric.com>
Generated for Model #20012OT3G447/9T-W40

Performed by

Checked

1 2 3 4 5 6 7 8

A

B

C

D

E

F

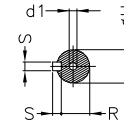
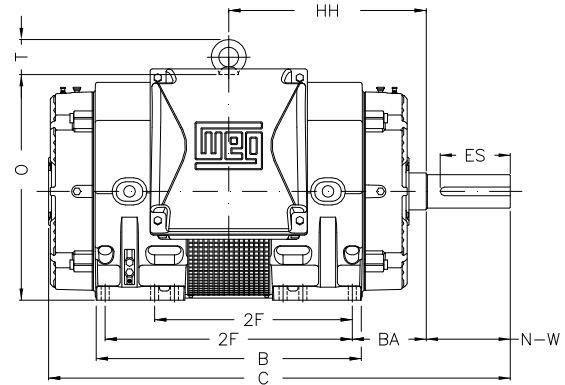
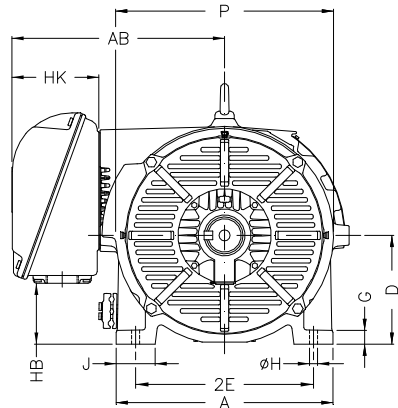
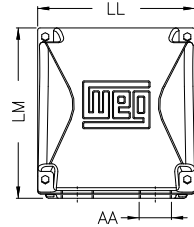

Notes: Downloaded from <http://dealerselectric.com>
Generated for Model #200120T3G447/9T-W40

2E 18.000	J 3.983	A 21.929	P 25.197	AB 21.505
2F 20.000/25.000	K 8.971	B 26.820	FK 8.971	EV 0.910
BA 7.480	U 3.375	d1 DUNC 7/8"-9	N-W 8.500	ES 7.087
S 0.875	R 2.882	depth 0.875	D 11.000	G 1.397
O 22.811	T 3.543	HH 19.980	H 0.810	C 46.709
AA 2xNPT 3"	DM NPT 3/4"	LL 15.904	LM 17.225	HK 8.907
HB 6.158				

Performed by:

Checked:

Customer:

W40 - Open Induction Motors – NEMA Premium Efficiency

Three-phase induction motor
Frame 447/9T - IP23

28-SEP-2016

