



Dealers Industrial Equipment

No.:

Date: 28-SEP-2016

Customer :

TECHNICAL PROPOSAL

Three-phase induction motor - Squirrel cage rotor

Product line : ODP – Open Induction Motors – NEMA Premium Efficiency

Catalog Number : 10036OT3V365TS

List Price : \$6,644

Notes:

Downloaded from <http://dealerselectric.com>

Generated for Model #10036OT3V365TS

Performed by:

Checked:



Dealers Industrial Equipment

No.:

Date: 28-SEP-2016

DATA SHEET Three-phase induction motor - Squirrel cage rotor

Customer :
 Product line : ODP – Open Induction Motors – NEMA Premium Efficiency

Frame : 365TS
 Output : 100 HP
 Frequency : 60 Hz
 Poles : 2
 Full load speed : 3550 rpm
 Slip : 1.39 %
 Voltage : 200/400 V
 Rated current : 255/128 A
 Locked rotor current : 1710/855 A
 Locked rotor current (I_L/I_n) : 6.7
 No-load current : 78.2/39.1 A
 Full load torque : 146 lb.ft
 Locked rotor torque : 190 %
 Breakdown torque : 280 %
 Design : B
 Insulation class : F
 Temperature rise : 80 K
 Locked rotor time : 12 s (hot)
 Service factor : 1.15
 Duty cycle : S1
 Ambient temperature : -20°C - +40°C
 Altitude : 1000 m
 Degree of Protection : IP23
 Approximate weight : 587 lb
 Moment of inertia : 8.3008 sq.ft.lb
 Noise level : 83 dB(A)

	D.E.	N.D.E.
Bearings	6314 C3	6314 C3
Regreasing interval	14418 h	14418 h
Grease amount	27 g	27 g

Load	Power factor	Efficiency (%)
100%	0.90	94.5
75%	0.89	94.5
50%	0.84	94.1

Notes:
 Downloaded from <http://dealerselectric.com>
 Generated for Model #10036OT3V365TS

Performed by

Checked



Dealers Industrial Equipment

No.:

Date: 28-SEP-2016

PERFORMANCE CURVES RELATED TO RATED OUTPUT

Three-phase induction motor - Squirrel cage rotor

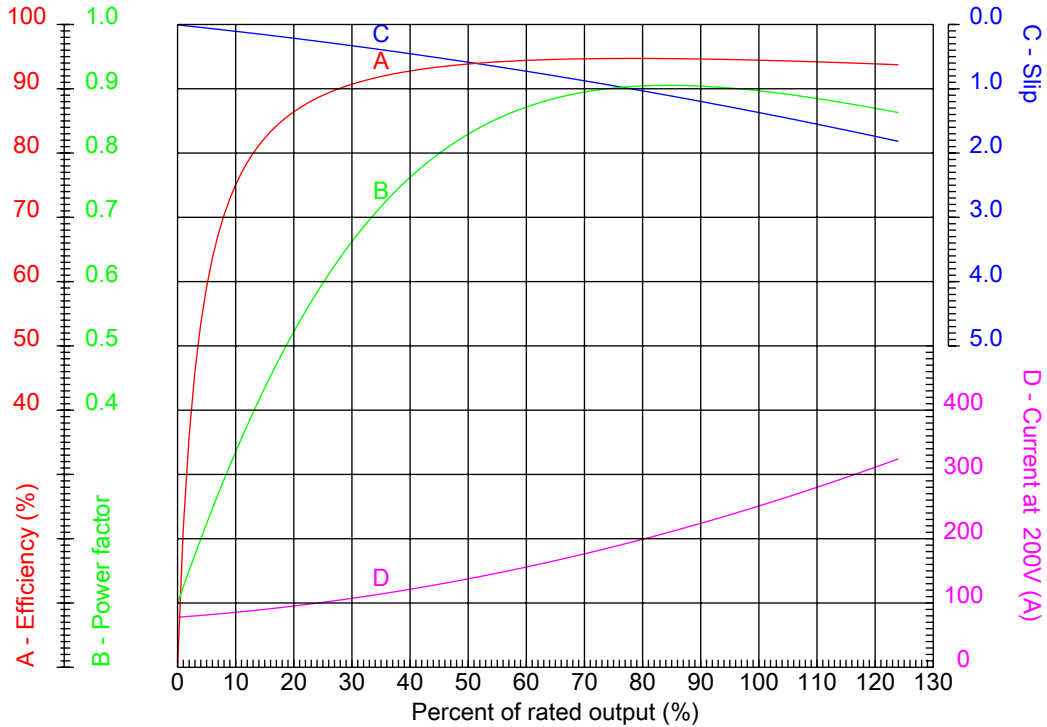

Customer :
 Product line : ODP – Open Induction Motors – NEMA Premium Efficiency

Frame	: 365TS	Locked rotor current (I _l /I _n)	: 6.7
Output	: 100 HP	Duty cycle	: S1
Frequency	: 60 Hz	Service factor	: 1.15
Full load speed	: 3550 rpm	Design	: B
Voltage	: 200/400 V	Locked rotor torque	: 190 %
Rated current	: 255/128 A	Breakdown torque	: 280 %
Insulation class	: F		

Notes:
 Downloaded from <http://dealerselectric.com>
 Generated for Model #10036OT3V365TS

Performed by

Checked



Dealers Industrial Equipment

No.:

Date: 28-SEP-2016

CHARACTERISTIC CURVES RELATED TO SPEED

Three-phase induction motor - Squirrel cage rotor

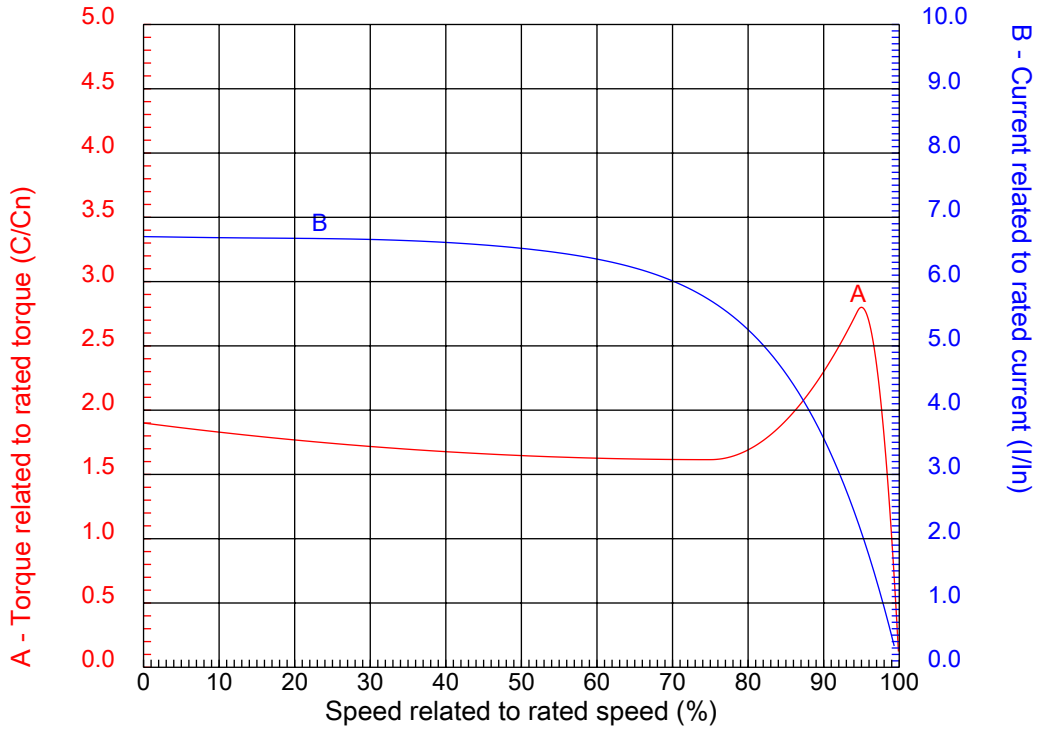

Customer :
Product line : ODP – Open Induction Motors – NEMA Premium Efficiency

Frame	: 365TS	Locked rotor current (I _l /I _n)	: 6.7
Output	: 100 HP	Duty cycle	: S1
Frequency	: 60 Hz	Service factor	: 1.15
Full load speed	: 3550 rpm	Design	: B
Voltage	: 200/400 V	Locked rotor torque	: 190 %
Rated current	: 255/128 A	Breakdown torque	: 280 %
Insulation class	: F		

Notes:
Downloaded from <http://dealerselectric.com>
Generated for Model #10036OT3V365TS

Performed by

Checked

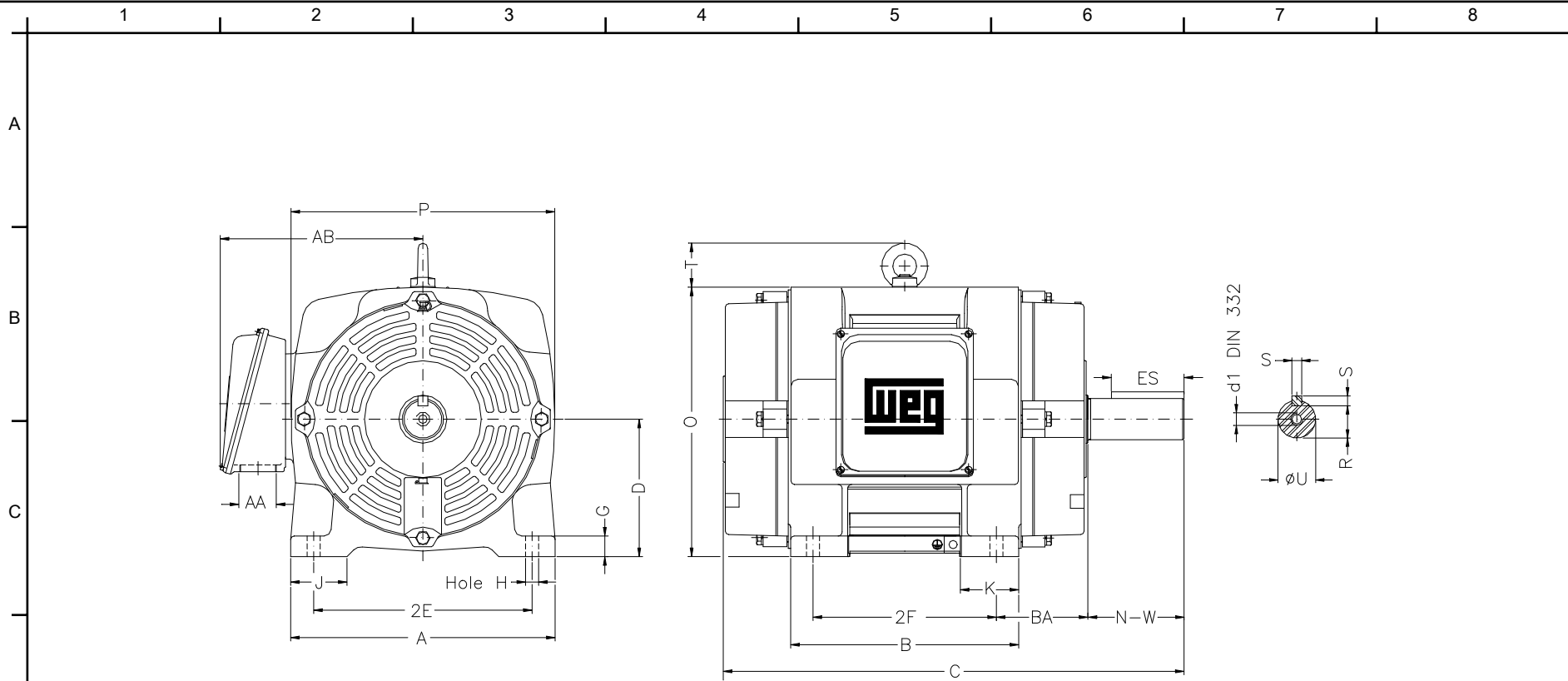

Notes: Downloaded from <http://dealerselectric.com>
 Generated for Model #100360T3V365TS

Performed by:

Checked:

Customer:

ODP – Open Induction Motors – NEMA Premium Efficiency

Three-phase induction motor
 Frame 365TS - IP23

28-SEP-2016



2E 14.000	J 3.150	A 17.170	P 17.874	AB 16.378
2F 11.250/12.250	K 4.140	B 15.400	BA 5.875	U 1.875
d1 DUNC 3/4"-10	N-W 3.748	ES 1.968	S 0.500	R 1.591
depth 0.500	D 9.000	G 1.480	O 18.425	T 2.795
H 0.657	C 27.638	AA NPT 3"		