



Dealers Industrial Equipment

No.:

Date: 28-SEP-2016

Customer :

TECHNICAL PROPOSAL

Three-phase induction motor - Squirrel cage rotor

Product line : ODP General Purpose

Catalog Number : 10018OT3E404T-G

List Price : \$8,341

Notes:

Downloaded from <http://dealerselectric.com>

Generated for Model #10018OT3E404T-G

Performed by:

Checked:



Dealers Industrial Equipment

No.:

Date: 28-SEP-2016

DATA SHEET

Three-phase induction motor - Squirrel cage rotor

Customer :
 Product line : ODP General Purpose

Frame : 404T
 Output : 100 HP
 Frequency : 60 Hz
 Poles : 4
 Full load speed : 1780 rpm
 Slip : 1.11 %
 Voltage : 208-230/460 V
 Rated current : 254-226/113 A
 Locked rotor current : 1510/757 A
 Locked rotor current (I_L/I_n) : 6.7
 No-load current : 84.0/42.0 A
 Full load torque : 291 lb.ft
 Locked rotor torque : 230 %
 Breakdown torque : 270 %
 Design : B
 Insulation class : F
 Temperature rise : 80 K
 Locked rotor time : 10 s (hot)
 Service factor : 1.15
 Duty cycle : S1
 Ambient temperature : -20°C - +40°C
 Altitude : 1000 m
 Degree of Protection : IP23
 Approximate weight : 1003 lb
 Moment of inertia : 22.836 sq.ft.lb
 Noise level : 69 dB(A)

	D.E.	N.D.E.	Load	Power factor	Efficiency (%)
Bearings	6316 C3	6314 C3	100%	0.87	95.4
Regreasing interval	20000 h	20000 h	75%	0.84	95.4
Grease amount	34 g	27 g	50%	0.77	95.0

Notes:
 Downloaded from <http://dealerselectric.com>
 Generated for Model #10018OT3E404T-G

Performed by

Checked



Dealers Industrial Equipment

No.:

Date: 28-SEP-2016

PERFORMANCE CURVES RELATED TO RATED OUTPUT

Three-phase induction motor - Squirrel cage rotor

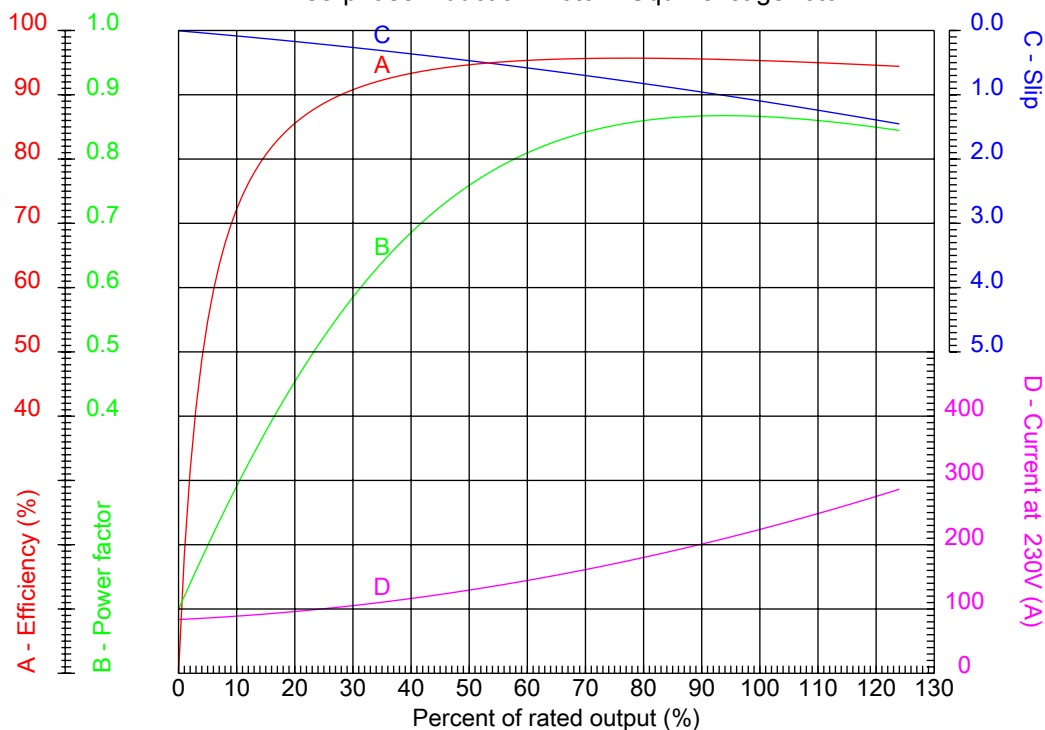

Customer :
Product line : ODP General Purpose

Frame : 404T	Locked rotor current (I _l /I _n) : 6.7
Output : 100 HP	Duty cycle : S1
Frequency : 60 Hz	Service factor : 1.15
Full load speed : 1780 rpm	Design : B
Voltage : 208-230/460 V	Locked rotor torque : 230 %
Rated current : 254-226/113 A	Breakdown torque : 270 %
Insulation class : F	

Notes:
Downloaded from <http://dealerselectric.com>
Generated for Model #10018OT3E404T-G

Performed by

Checked



CHARACTERISTIC CURVES RELATED TO SPEED

Three-phase induction motor - Squirrel cage rotor

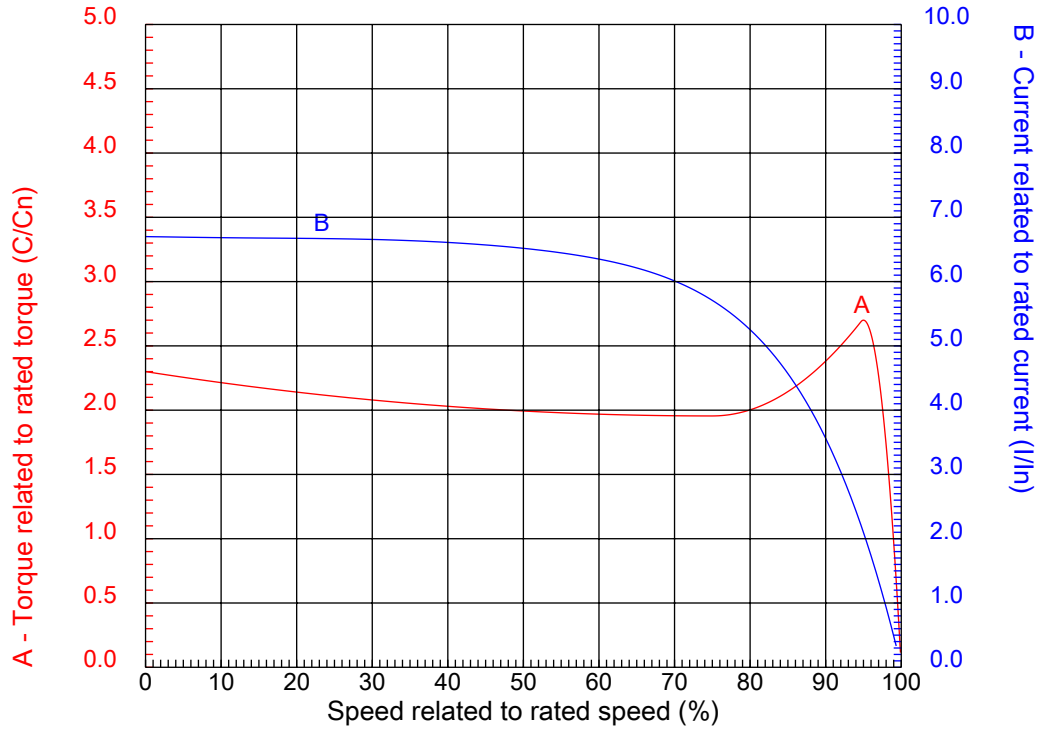

Customer :
Product line : ODP General Purpose

Frame	: 404T	Locked rotor current (I _l /I _n)	: 6.7
Output	: 100 HP	Duty cycle	: S1
Frequency	: 60 Hz	Service factor	: 1.15
Full load speed	: 1780 rpm	Design	: B
Voltage	: 208-230/460 V	Locked rotor torque	: 230 %
Rated current	: 254-226/113 A	Breakdown torque	: 270 %
Insulation class	: F		

Notes:
Downloaded from <http://dealerselectric.com>
Generated for Model #10018OT3E404T-G

Performed by

Checked

1 2 3 4 5 6 7 8

A

B

C

D

E

F

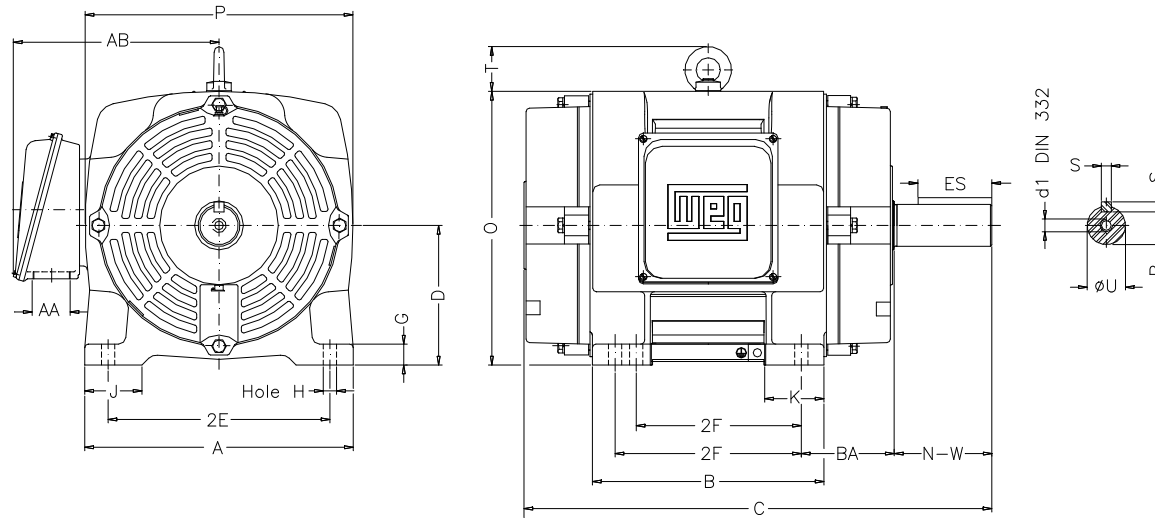

Notes: Downloaded from <http://dealerselectric.com>
Generated for Model #100180T3E404T-G

Performed by:

Checked:

Customer:

ODP General Purpose

Three-phase induction motor
Frame 404T - IP23

28-SEP-2016



2E 16.000	A 19.950	2F 12.250/13.750	B 17.700	BA 6.625
J 3.950	K 5.440	P 17.874	ES 5.512	depth 0.750
S 0.750	D 10.000	N-W 7.250	G 1.968	U 2.875
O 19.409	T 2.800	R 2.449	H 0.810	AB 16.378
C 34.133	AA NPT 3"	d1 DUNC 3/4"-10		