



Dealers Industrial Equipment

No.:

Date: 27-SEP-2016

Customer :

TECHNICAL PROPOSAL

Three-phase induction motor - Squirrel cage rotor

Product line : Three-Phase : Explosion Proof - High Efficiency

Catalog Number : 07509XP3E444T

List Price : \$21,094

Notes:

Downloaded from <http://dealerselectric.com>

Generated for Model #07509XP3E444T

Performed by:

Checked:



Dealers Industrial Equipment

No.:

Date: 27-SEP-2016

DATA SHEET Three-phase induction motor - Squirrel cage rotor

Customer :
 Product line : Three-Phase : Explosion Proof - High Efficiency

Frame : 444T
 Output : 75 HP
 Frequency : 60 Hz
 Poles : 8
 Full load speed : 890 rpm
 Slip : 1.11 %
 Voltage : 208-230/460 V
 Rated current : 200-181/90.5 A
 Locked rotor current : 1100/552 A
 Locked rotor current (I_L/I_n) : 6.1
 No-load current : 72.5/36.3 A
 Full load torque : 437 lb.ft
 Locked rotor torque : 170 %
 Breakdown torque : 210 %
 Design : B
 Insulation class : F
 Temperature rise : 80 K
 Locked rotor time : 28 s (hot)
 Service factor : 1.15
 Duty cycle : S1
 Ambient temperature : -20°C - +40°C
 Altitude : 1000 m
 Degree of Protection : IP54
 Approximate weight : 1911 lb
 Moment of inertia : 73.625 sq.ft.lb
 Noise level : 64 dB(A)

	D.E.	N.D.E.	Load	Power factor	Efficiency (%)
Bearings	6219 C3	6316 C3	100%	0.82	93.0
Regreasing interval	15247 h	15904 h	75%	0.78	92.4
Grease amount	27 g	34 g	50%	0.69	91.7

Notes:
 Downloaded from <http://dealerselectric.com>
 Generated for Model #07509XP3E444T

Performed by

Checked



Dealers Industrial Equipment

No.:

Date: 27-SEP-2016

PERFORMANCE CURVES RELATED TO RATED OUTPUT

Three-phase induction motor - Squirrel cage rotor

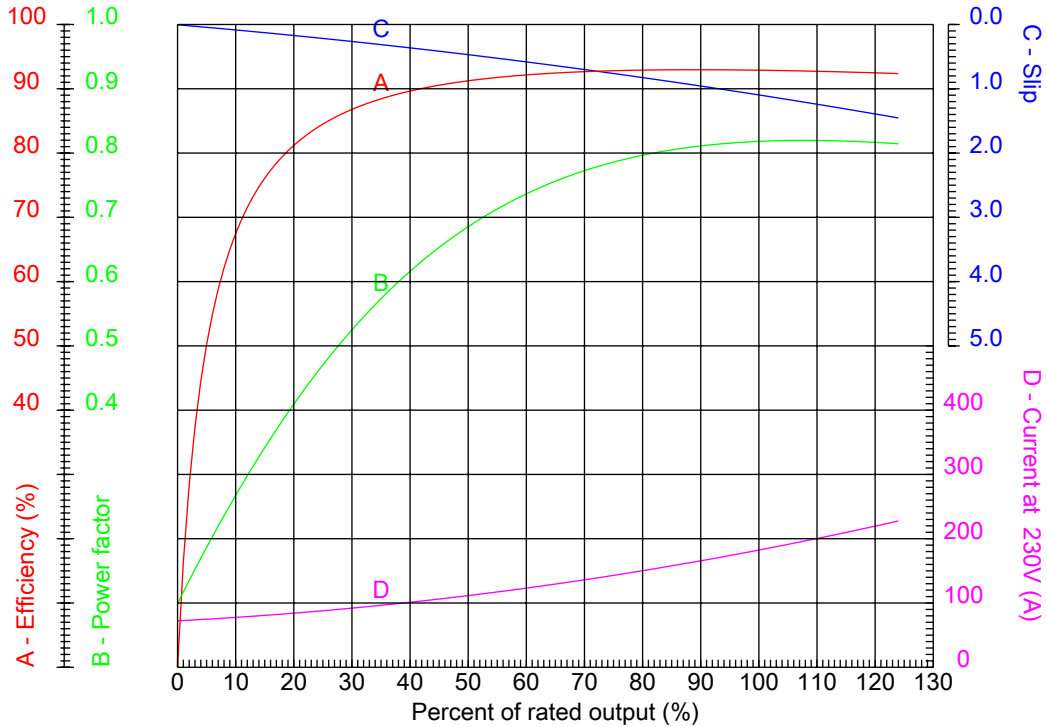

Customer :
 Product line : Three-Phase : Explosion Proof - High Efficiency

Frame	: 444T	Locked rotor current (I _l /I _n)	: 6.1
Output	: 75 HP	Duty cycle	: S1
Frequency	: 60 Hz	Service factor	: 1.15
Full load speed	: 890 rpm	Design	: B
Voltage	: 208-230/460 V	Locked rotor torque	: 170 %
Rated current	: 200-181/90.5 A	Breakdown torque	: 210 %
Insulation class	: F		

Notes:
 Downloaded from <http://dealerselectric.com>
 Generated for Model #07509XP3E444T

Performed by

Checked



CHARACTERISTIC CURVES RELATED TO SPEED

Three-phase induction motor - Squirrel cage rotor

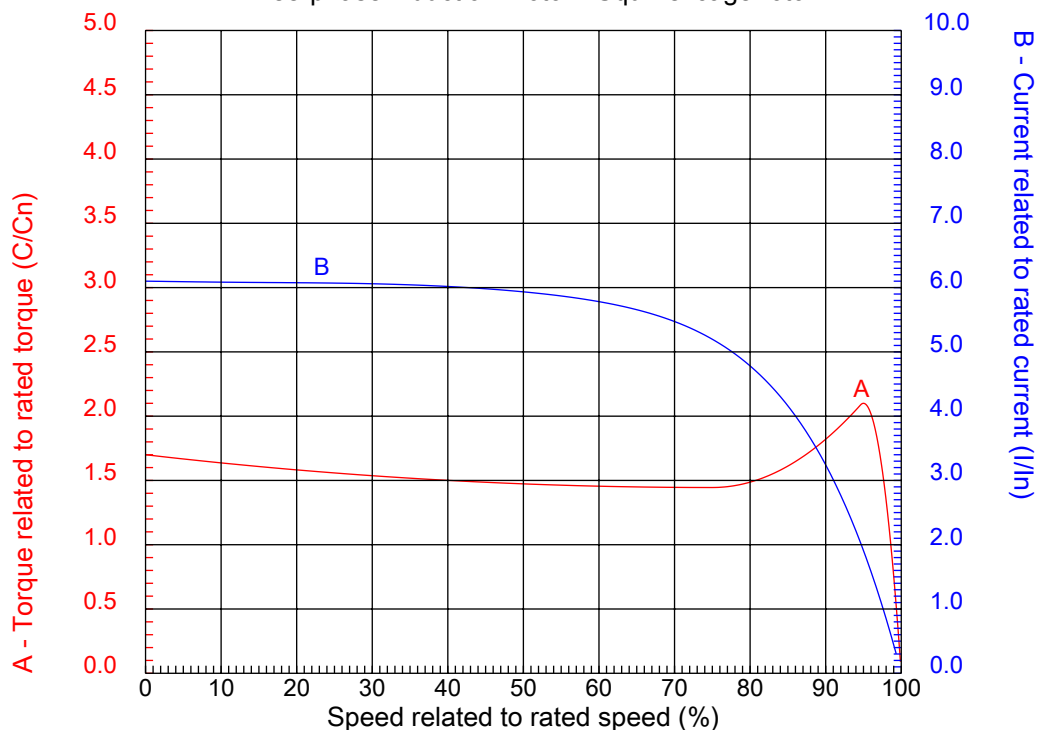

Customer :
Product line : Three-Phase : Explosion Proof - High Efficiency

Frame	: 444T	Locked rotor current (I _l /I _n)	: 6.1
Output	: 75 HP	Duty cycle	: S1
Frequency	: 60 Hz	Service factor	: 1.15
Full load speed	: 890 rpm	Design	: B
Voltage	: 208-230/460 V	Locked rotor torque	: 170 %
Rated current	: 200-181/90.5 A	Breakdown torque	: 210 %
Insulation class	: F		

Notes:
Downloaded from <http://dealerselectric.com>
Generated for Model #07509XP3E444T

Performed by

Checked

1 2 3 4 5 6 7 8

A
B
C
D
E
F

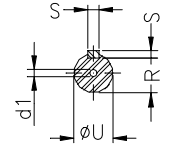
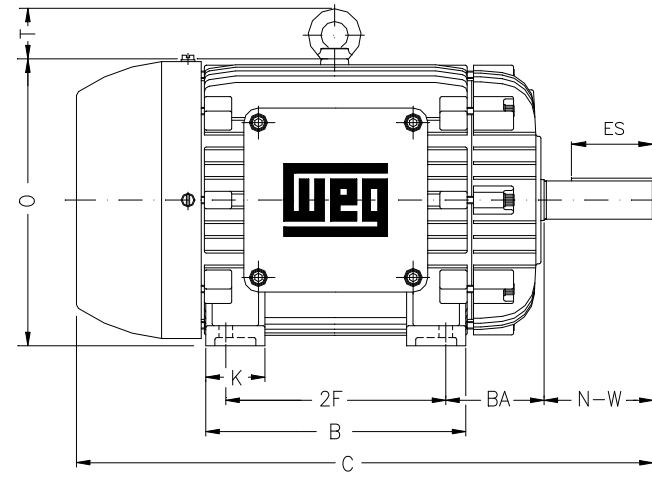
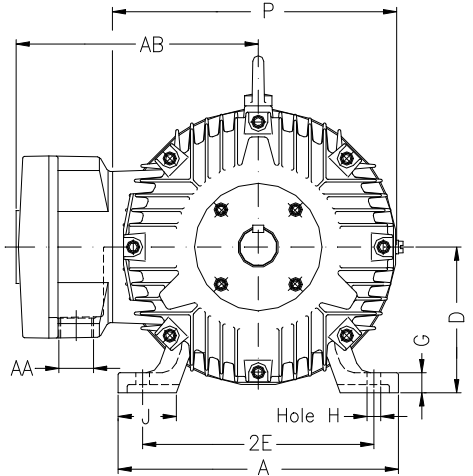

Notes: Downloaded from <http://dealerselectric.com>
Generated for Model #07509XP3E444T

Performed by:

Checked:

Customer:

Three-Phase : Explosion Proof - High Efficiency

2E 18.000	A 21.929	2F 14.500/16.500	B 20.079	BA 7.500
J 3.937	FBA 11.769/13.769	K 5.591	P 24.016	ES 7.087
depth 0.875	S 0.875	N-W 8.500	U 3.375	R 2.880
AB 21.732	D 11.000	G 1.630	O 23.622	H 0.807
C 43.797	FC 50.143	AA 2xNPT 3"	d1 DUNC 3/4"-10	d2 DUNC 3/4"-10
T 3.543				

Three-phase induction motor
Frame 444T - IP54

27-SEP-2016

