



Dealers Industrial Equipment

No.:

Date: 23-SEP-2016

Customer :

TECHNICAL PROPOSAL

Three-phase induction motor - Squirrel cage rotor

Product line : Three-Phase : Explosion Proof - NEMA Premium

Catalog Number : 03018XT3ER286TC

List Price : \$4,758

Notes:

Downloaded from <http://dealerselectric.com>

Generated for Model #03018XT3ER286TC

Performed by:

Checked:



Dealers Industrial Equipment

No.:

Date: 23-SEP-2016

DATA SHEET Three-phase induction motor - Squirrel cage rotor

Customer :
 Product line : Three-Phase : Explosion Proof - NEMA Premium

Frame : 286T
 Output : 30 HP
 Frequency : 60 Hz
 Poles : 4
 Full load speed : 1770 rpm
 Slip : 1.67 %
 Voltage : 208-230/460 V
 Rated current : 79.6-72.0/36.0 A
 Locked rotor current : 590/295 A
 Locked rotor current (I_L/I_n) : 8.2
 No-load current : 32.0/16.0 A
 Full load torque : 87.8 lb.ft
 Locked rotor torque : 300 %
 Breakdown torque : 300 %
 Design : B
 Insulation class : F
 Temperature rise : 80 K
 Locked rotor time : 17 s (hot)
 Service factor : 1.15
 Duty cycle : S1
 Ambient temperature : -20°C - +40°C
 Altitude : 1000 m
 Degree of Protection : IP55
 Approximate weight : 512 lb
 Moment of inertia : 5.1620 sq.ft.lb
 Noise level : 68 dB(A)

	D.E.	N.D.E.
Bearings	6311 2RS-C3	6211 2RS-C3
Regreasing interval	---	---
Grease amount	---	---

Load	Power factor	Efficiency (%)
100%	0.82	93.6
75%	0.77	93.6
50%	0.66	93.0

Notes:
 Downloaded from <http://dealerselectric.com>
 Generated for Model #03018XT3ER286TC

Performed by

Checked



Dealers Industrial Equipment

No.:

Date: 23-SEP-2016

PERFORMANCE CURVES RELATED TO RATED OUTPUT

Three-phase induction motor - Squirrel cage rotor

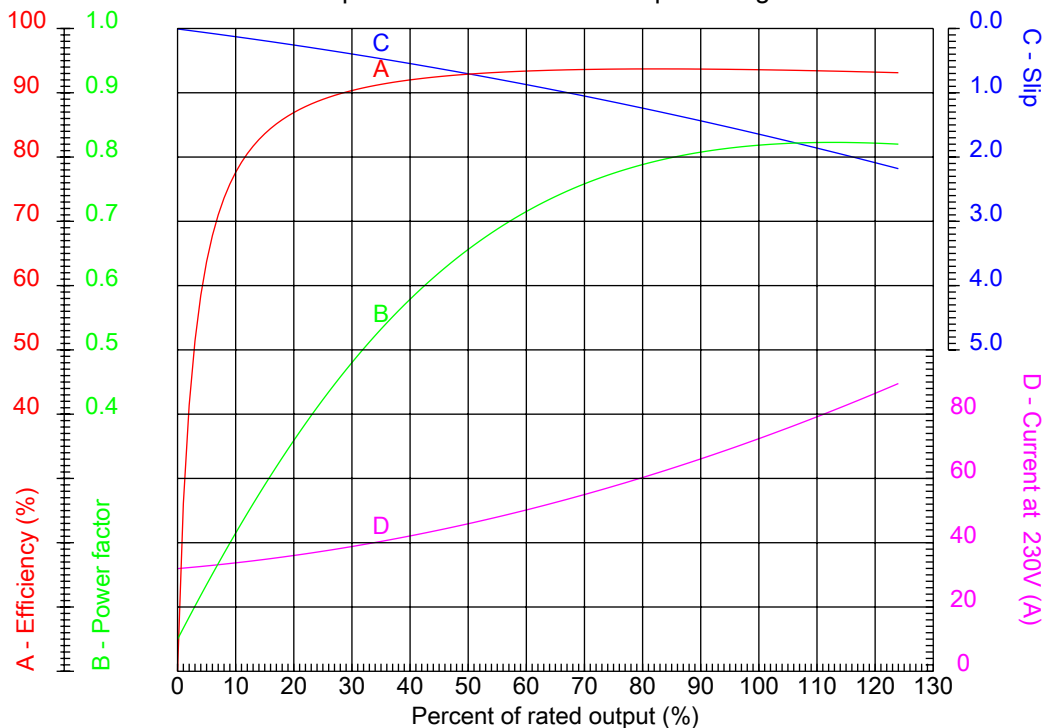

Customer :
 Product line : Three-Phase : Explosion Proof - NEMA Premium

Frame	: 286T	Locked rotor current (I _L /I _n)	: 8.2
Output	: 30 HP	Duty cycle	: S1
Frequency	: 60 Hz	Service factor	: 1.15
Full load speed	: 1770 rpm	Design	: B
Voltage	: 208-230/460 V	Locked rotor torque	: 300 %
Rated current	: 79.6-72.0/36.0 A	Breakdown torque	: 300 %
Insulation class	: F		

Notes:
 Downloaded from <http://dealerselectric.com>
 Generated for Model #03018XT3ER286TC

Performed by

Checked



Dealers Industrial Equipment

No.:

Date: 23-SEP-2016

CHARACTERISTIC CURVES RELATED TO SPEED

Three-phase induction motor - Squirrel cage rotor

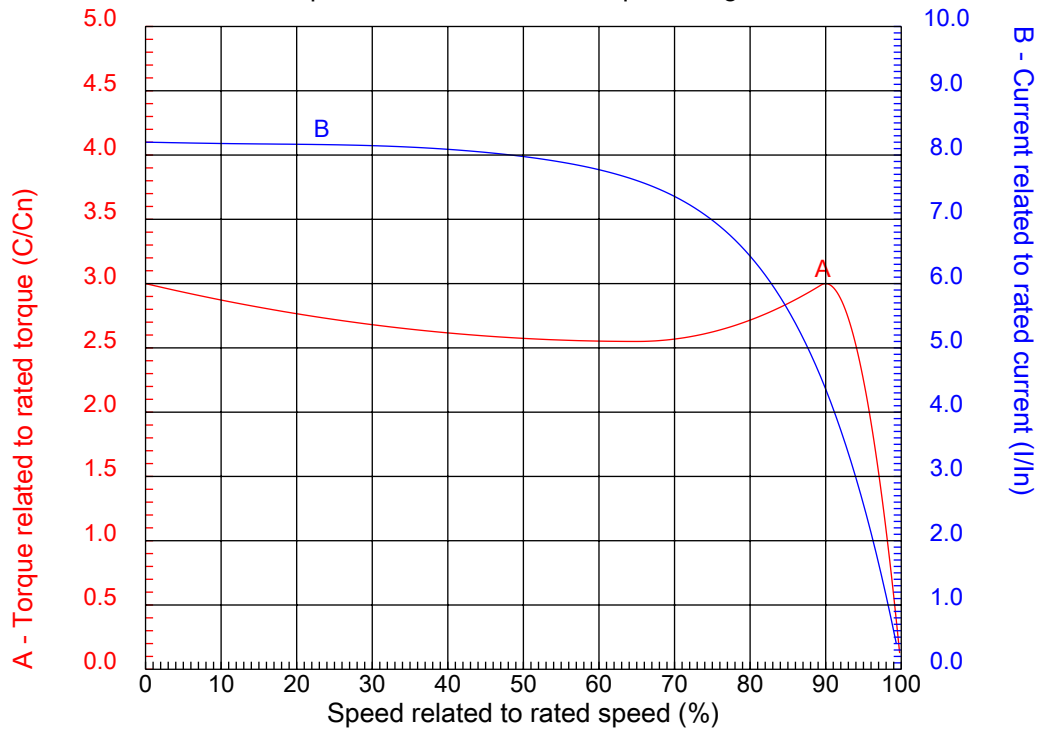

Customer :
Product line : Three-Phase : Explosion Proof - NEMA Premium

Frame	: 286T	Locked rotor current (I _l /I _n)	: 8.2
Output	: 30 HP	Duty cycle	: S1
Frequency	: 60 Hz	Service factor	: 1.15
Full load speed	: 1770 rpm	Design	: B
Voltage	: 208-230/460 V	Locked rotor torque	: 300 %
Rated current	: 79.6-72.0/36.0 A	Breakdown torque	: 300 %
Insulation class	: F		

Notes:
Downloaded from <http://dealerselectric.com>
Generated for Model #03018XT3ER286TC

Performed by

Checked

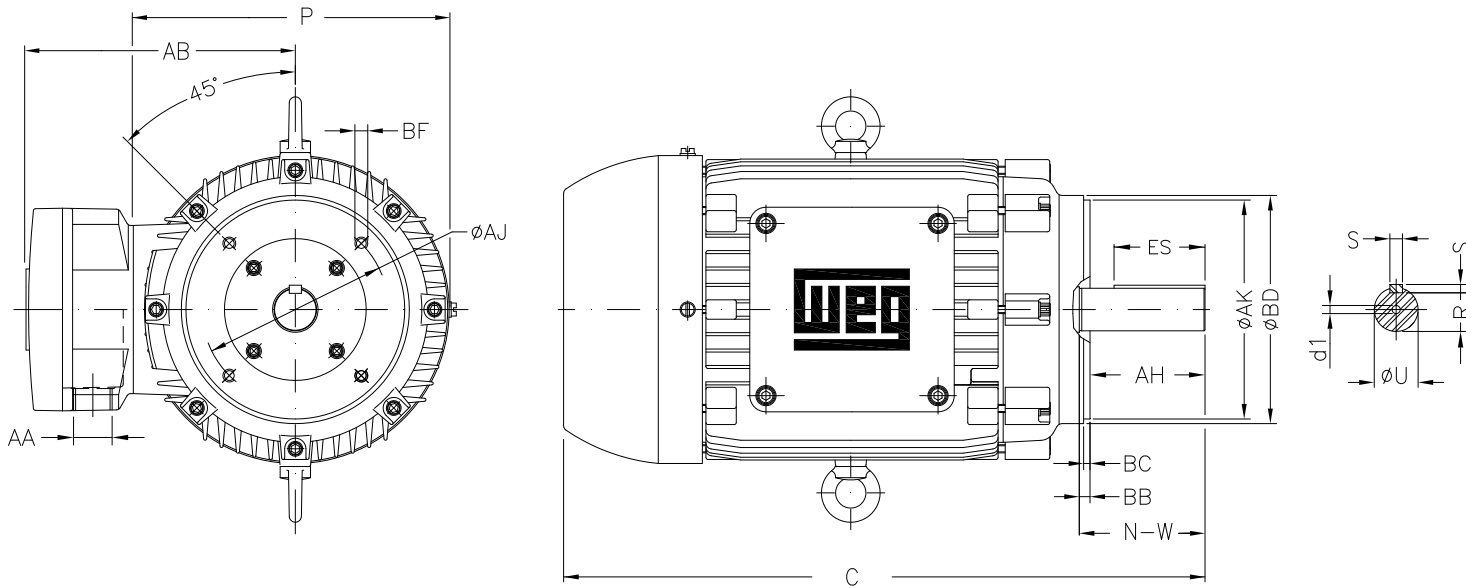

Notes: Downloaded from <http://dealerselectric.com>
 Generated for Model #03018XT3ER286TC

Performed by:

Checked:

Customer:

Three-Phase : Explosion Proof - NEMA Premium

P	ES	S	depth	N-W
14.094	3.149	0.500	0.500	4.622
U	R	AB	C	AA
1.875	1.594	11.850	27.905	NPT 1 1/2"
d1	d2	Flange	AJ	AK
A 4	A 4	FC-228	9.000	10.500
BD	BF	BB	BC	AH
11.031	UNC 1/2"x13	0.250	0.250	4.375

Three-phase induction motor
 Frame 286T - IP55

23-SEP-2016



1 2 3 4 5 6 7 8

A
B
C
D
E
F

LOW VOLTAGE

HIGH VOLTAGE



CONNECTIONS FOR STARTING ONLY:

LOW VOLTAGE

HIGH VOLTAGE



Notes: Downloaded from <http://dealerselectric.com>
Generated for Model #03018XT3ER286TC

Performed by:

Checked:

Customer:

Three-Phase : Explosion Proof - NEMA Premium

Three-phase induction motor
Frame 286T - IP55

23-SEP-2016

