



Dealers Industrial Equipment

No.:

Date: 23-SEP-2016

Customer :

TECHNICAL PROPOSAL

Three-phase induction motor - Squirrel cage rotor

Product line : Three-Phase: W22 IE2 IEC Tru-Metric - TEFC (IP55) Cast Iron Frame

Catalog Number : 03009EP3Y250S/M-W22

List Price : \$7,909

Notes:

Downloaded from <http://dealerselectric.com>

Generated for Model #03009EP3Y250S/M-W22

Performed by:

Checked:



Dealers Industrial Equipment

No.:

Date: 23-SEP-2016

DATA SHEET

Three-phase induction motor - Squirrel cage rotor

Customer :
 Product line : Three-Phase: W22 IE2 IEC Tru-Metric - TEFC (IP55) Cast Iron Frame

Frame : 250S/M
 Output : 40 HP
 Frequency : 60 Hz
 Poles : 8
 Full load speed : 880 rpm
 Slip : 2.22 %
 Voltage : 460 V
 Rated current : 49.1 A
 Locked rotor current : 383 A
 Locked rotor current (I_L/I_n) : 7.8
 No-load current : 22.9 A
 Full load torque : 235 lb.ft
 Locked rotor torque : 220 %
 Breakdown torque : 300 %
 Design : ---
 Insulation class : F
 Temperature rise : 80 K
 Locked rotor time : 13 s (hot)
 Service factor : 1.15
 Duty cycle : S1
 Ambient temperature : -20°C - +40°C
 Altitude : 1000 m
 Degree of Protection : IP55
 Approximate weight : 955 lb
 Moment of inertia : 25.216 sq.ft.lb
 Noise level : 60 dB(A)

	D.E.	N.D.E.
Bearings	6314 C3	6314 C3
Regreasing interval	20000 h	20000 h
Grease amount	27 g	27 g

Load	Power factor	Efficiency (%)
100%	0.83	92.4
75%	0.78	92.4
50%	0.66	91.7

Notes:
 Downloaded from <http://dealerselectric.com>
 Generated for Model #03009EP3Y250S/M-W22

Performed by

Checked



Dealers Industrial Equipment

No.:

Date: 23-SEP-2016

PERFORMANCE CURVES RELATED TO RATED OUTPUT Three-phase induction motor - Squirrel cage rotor

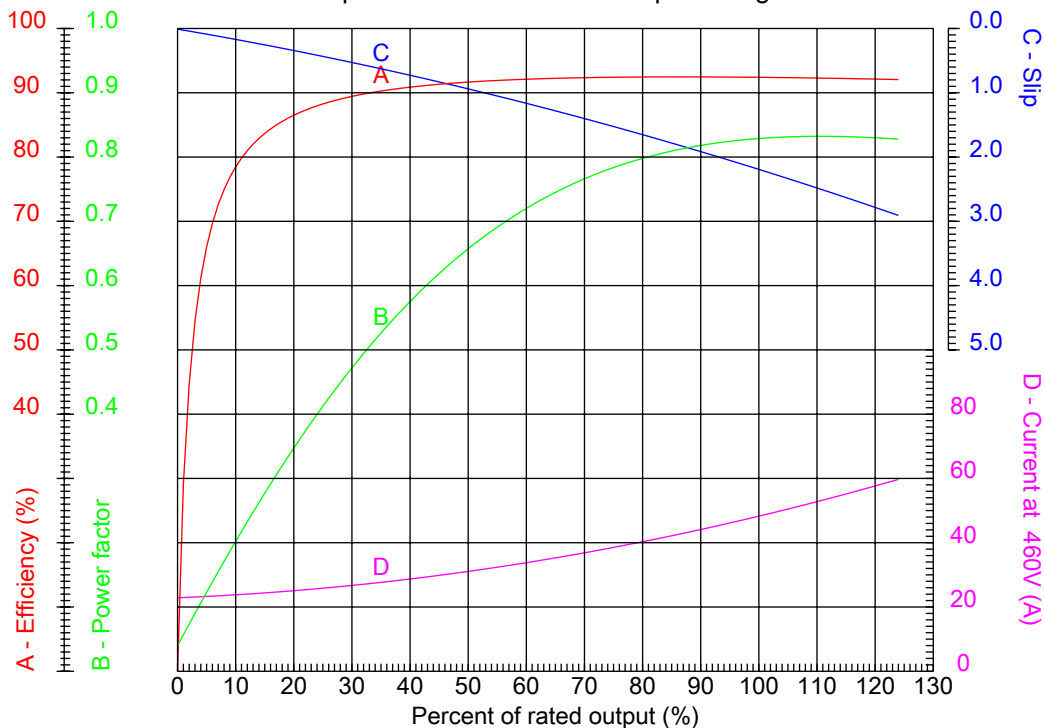

Customer :
 Product line : Three-Phase: W22 IE2 IEC Tru-Metric - TEFC (IP55) Cast Iron Frame

Frame	: 250S/M	Locked rotor current (I _l /I _n)	: 7.8
Output	: 40 HP	Duty cycle	: S1
Frequency	: 60 Hz	Service factor	: 1.15
Full load speed	: 880 rpm	Design	: ---
Voltage	: 460 V	Locked rotor torque	: 220 %
Rated current	: 49.1 A	Breakdown torque	: 300 %
Insulation class	: F		

Notes:
 Downloaded from <http://dealerselectric.com>
 Generated for Model #03009EP3Y250S/M-W22

Performed by

Checked



Dealers Industrial Equipment

No.:

Date: 23-SEP-2016

CHARACTERISTIC CURVES RELATED TO SPEED

Three-phase induction motor - Squirrel cage rotor

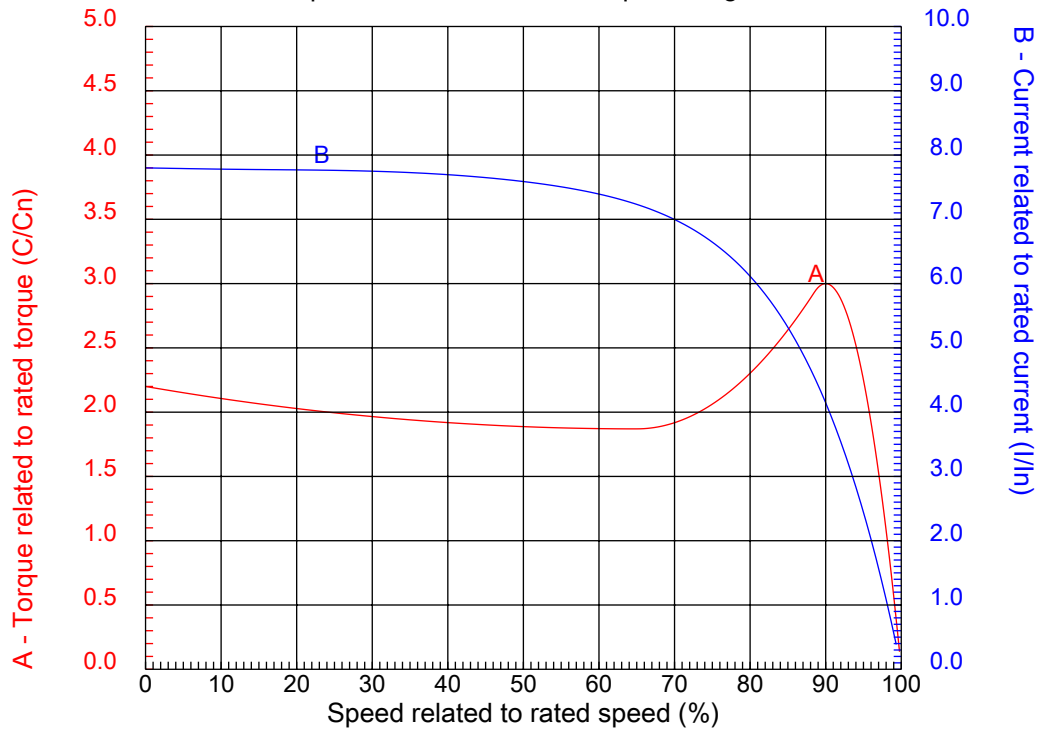

Customer :
Product line : Three-Phase: W22 IE2 IEC Tru-Metric - TEFC (IP55) Cast Iron Frame

Frame	: 250S/M	Locked rotor current (I _l /I _n)	: 7.8
Output	: 40 HP	Duty cycle	: S1
Frequency	: 60 Hz	Service factor	: 1.15
Full load speed	: 880 rpm	Design	: ---
Voltage	: 460 V	Locked rotor torque	: 220 %
Rated current	: 49.1 A	Breakdown torque	: 300 %
Insulation class	: F		

Notes:
Downloaded from <http://dealerselectric.com>
Generated for Model #03009EP3Y250S/M-W22

Performed by

Checked

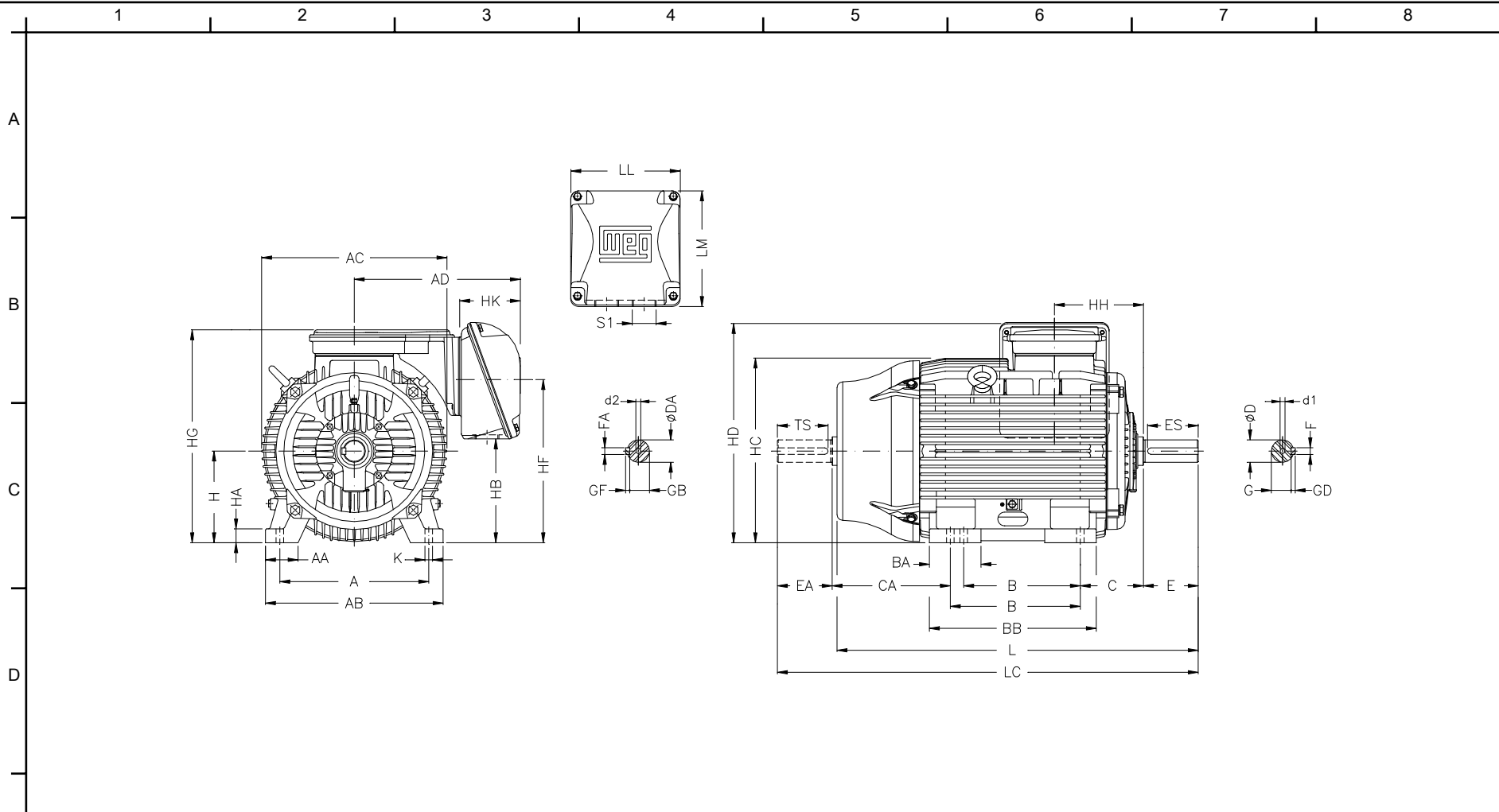

Notes: Downloaded from <http://dealerselectric.com>
 Generated for Model #03009EP3Y250S/M-W22

E	A 406	AA 100	AB 506	AC 486	AD 410
	B 311/349	BA 146	BB 467	C 168	CA 354/316
	D 65m6	E 140	ES 125	F 18	G 58
	GD 11	DA 60m6	EA 140	TS 125	FA 18
	GB 53	GF 11	H 250	HA 43	HB 297
F	HC 493	HD 583	HF 463	HG 577	HH 214
	HK 153	K 24	L 965	LC 1113	LL 269
	LM 285	S1 2xM63x1.5	d1 DM20	d2 DM20	

Performed by:

Checked:

Customer:

Three-Phase: W22 IE2 IEC Tru-Metric - TEFC (IP55) Cast Iron Frame

Three-phase induction motor
 Frame 250S/M - IP55

23-SEP-2016

