



Dealers Industrial Equipment

No.:

Date: 23-SEP-2016

Customer :

TECHNICAL PROPOSAL

Three-phase induction motor - Squirrel cage rotor

Product line : W01 (Rolled Steel) General Purpose TEFC

Catalog Number : 01536ET3H254T-SG

List Price : \$1,869

Notes:

Downloaded from <http://dealerselectric.com>

Generated for Model #01536ET3H254T-SG

Performed by:

Checked:



# Dealers Industrial Equipment

No.:

Date: 23-SEP-2016

## DATA SHEET Three-phase induction motor - Squirrel cage rotor

Customer :  
 Product line : W01 (Rolled Steel) General Purpose TEFC

Frame : 254/6T  
 Output : 15 HP  
 Frequency : 60 Hz  
 Poles : 2  
 Full load speed : 3525 rpm  
 Slip : 2.08 %  
 Voltage : 575 V  
 Rated current : 13.9 A  
 Locked rotor current : 97.4 A  
 Locked rotor current (I<sub>L</sub>/I<sub>n</sub>) : 7.0  
 No-load current : 5.20 A  
 Full load torque : 22.0 lb.ft  
 Locked rotor torque : 200 %  
 Breakdown torque : 300 %  
 Design : B  
 Insulation class : F  
 Temperature rise : 80 K  
 Locked rotor time : 14 s (hot)  
 Service factor : 1.15  
 Duty cycle : S1  
 Ambient temperature : -20°C - +40°C  
 Altitude : 1000 m  
 Degree of Protection : IP55  
 Approximate weight : 175 lb  
 Moment of inertia : 0.87184 sq.ft.lb  
 Noise level : 75 dB(A)

	D.E.	N.D.E.	Load	Power factor	Efficiency (%)
Bearings	6309 Z-C3	6208 Z-C3	100%	0.87	91.0
Regreasing interval	15797 h	20000 h	75%	0.83	91.0
Grease amount	13 g	8 g	50%	0.73	89.5

Notes:  
 Downloaded from <http://dealerselectric.com>  
 Generated for Model #01536ET3H254T-SG

Performed by

Checked



# Dealers Industrial Equipment

No.:

Date: 23-SEP-2016

## PERFORMANCE CURVES RELATED TO RATED OUTPUT

Three-phase induction motor - Squirrel cage rotor

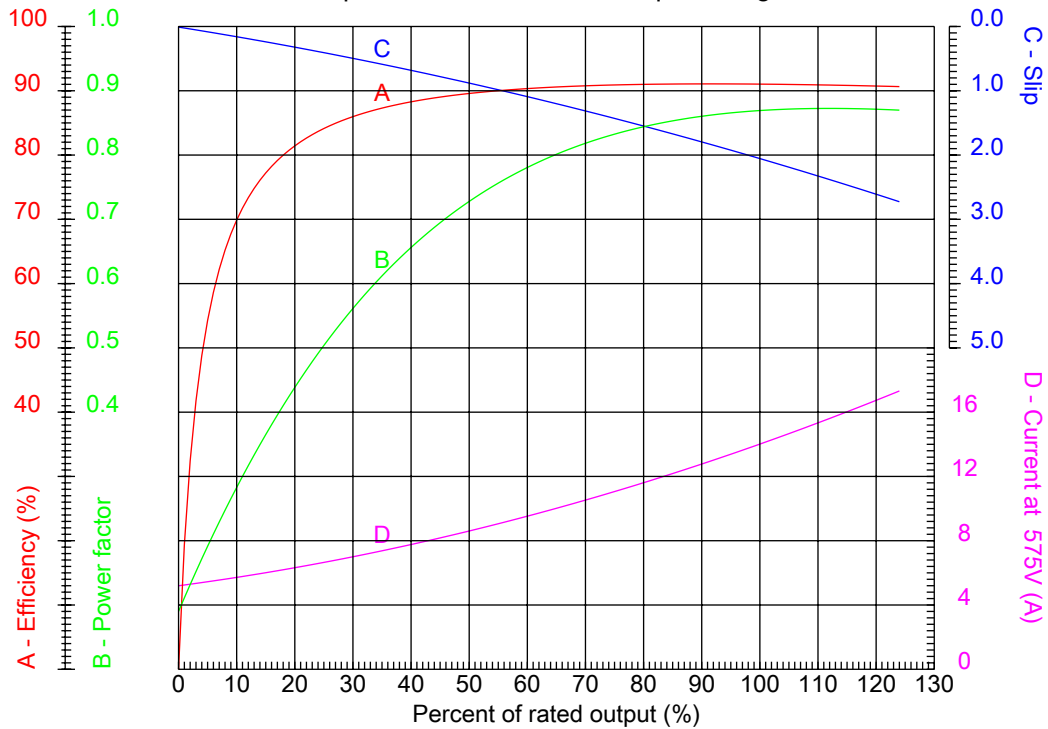

Customer :  
Product line : W01 (Rolled Steel) General Purpose TEFC

Frame : 254/6T	Locked rotor current (I <sub>l</sub> /I <sub>n</sub> ) : 7.0
Output : 15 HP	Duty cycle : S1
Frequency : 60 Hz	Service factor : 1.15
Full load speed : 3525 rpm	Design : B
Voltage : 575 V	Locked rotor torque : 200 %
Rated current : 13.9 A	Breakdown torque : 300 %
Insulation class : F	

Notes:  
Downloaded from <http://dealerselectric.com>  
Generated for Model #01536ET3H254T-SG

Performed by

Checked



# Dealers Industrial Equipment

No.:

Date: 23-SEP-2016

## CHARACTERISTIC CURVES RELATED TO SPEED

Three-phase induction motor - Squirrel cage rotor

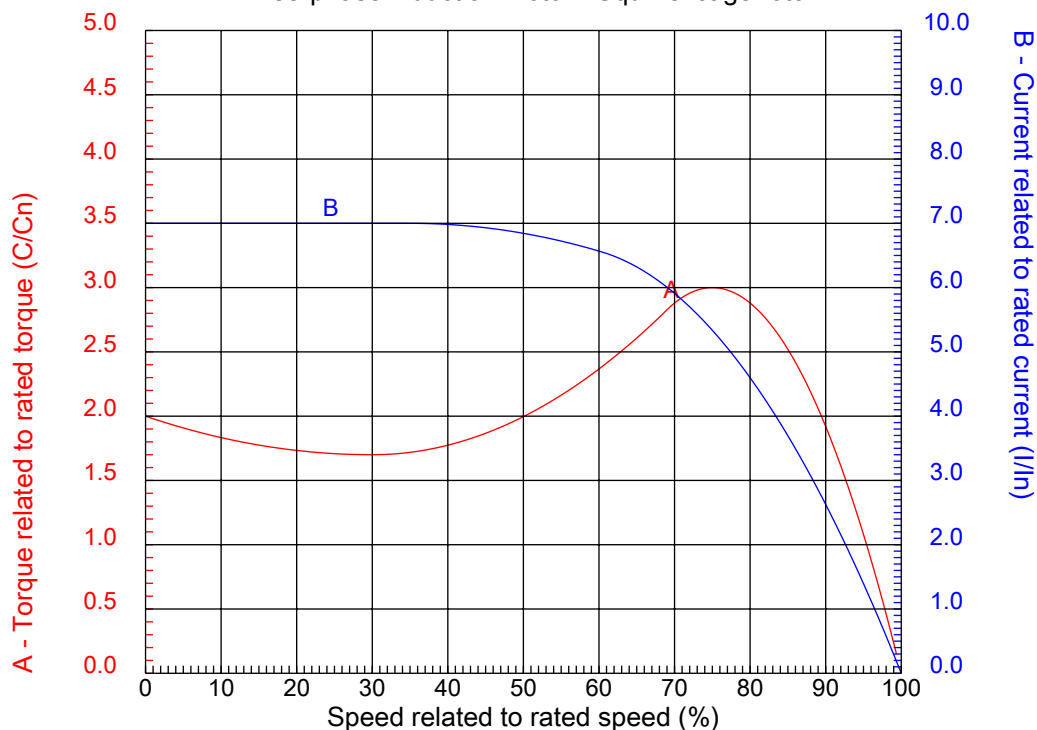

Customer :  
Product line : W01 (Rolled Steel) General Purpose TEFC

Frame	: 254/6T	Locked rotor current (I <sub>l</sub> /I <sub>n</sub> )	: 7.0
Output	: 15 HP	Duty cycle	: S1
Frequency	: 60 Hz	Service factor	: 1.15
Full load speed	: 3525 rpm	Design	: B
Voltage	: 575 V	Locked rotor torque	: 200 %
Rated current	: 13.9 A	Breakdown torque	: 300 %
Insulation class	: F		

Notes:  
Downloaded from <http://dealerselectric.com>  
Generated for Model #01536ET3H254T-SG

Performed by

Checked

1 2 3 4 5 6 7 8

A

B

C

D

E

F

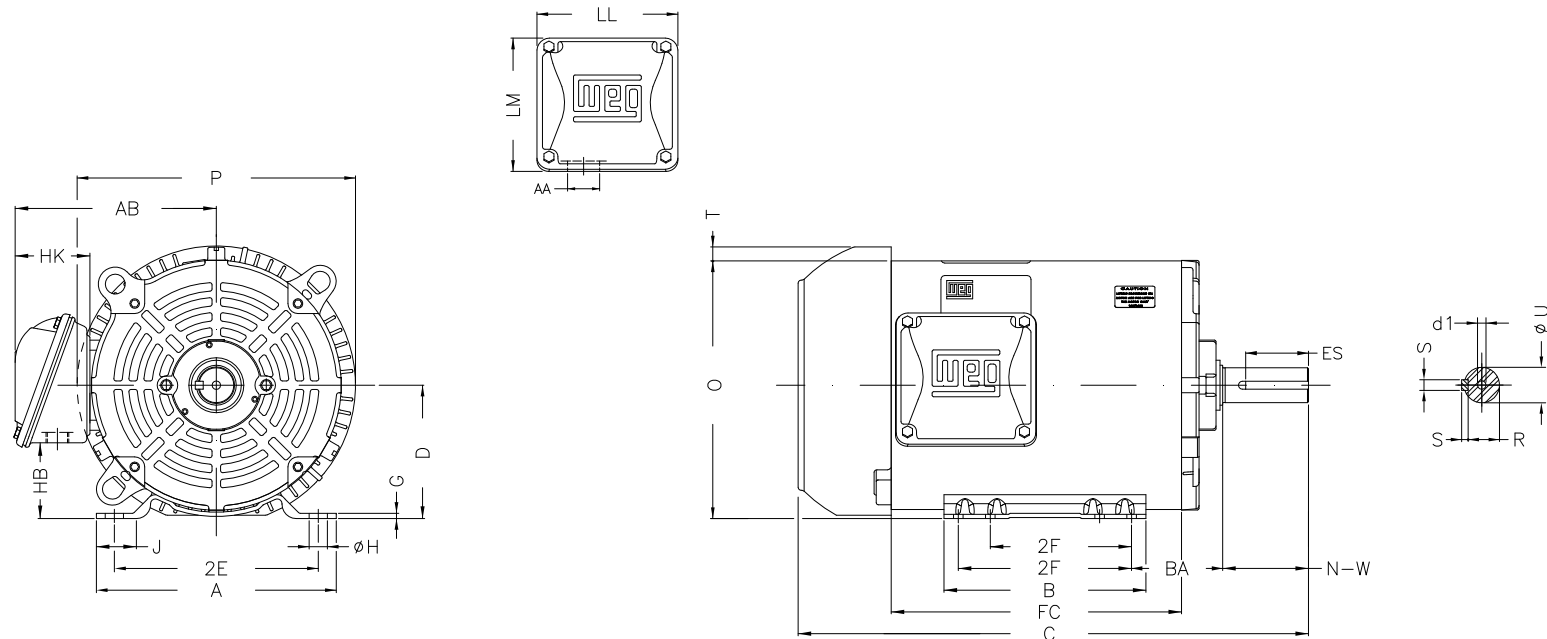

Notes: Downloaded from <http://dealerselectric.com>  
Generated for Model #01536ET3H254T-SG

Performed by:

Checked:

Customer:

W01 (Rolled Steel) General Purpose TEFC

Three-phase induction motor  
Frame 254/6T - IP55

23-SEP-2016



P	AB	J	2E	A
13.180	9.448	1.693	10.000	11.417
H	G	HB	HK	T
0.530	0.187	3.631	3.645	0.830
O	FC	2F	B	C
12.010	12.992	8.252/10.000	11.417	22.559
BA	N-W	ES	d1	S
4.250	4.000	2.756	A4	0.375
U	AA	depth	R	LL
1.625	1.732"	0.375	1.416	6.299
LM	BB	D	CH	
6.017	0.830	6.250	1.929	

1 2 3 4 5 6 7 8

A  
B  
C  
D  
E  
F

### RUN



### ONLY FOR START



Notes: Downloaded from <a href="http://dealerselectric.com">http://dealerselectric.com</a> Generated for Model #01536ET3H254T-SG		
Performed by:		
Checked:		
Customer:		
W01 (Rolled Steel) General Purpose TEFC		
Three-phase induction motor Frame 254/6T - IP55	23-SEP-2016	