



Dealers Industrial Equipment

No.:

Date: 23-SEP-2016

Customer :

TECHNICAL PROPOSAL

Three-phase induction motor - Squirrel cage rotor

Product line : Three-Phase: W22 IE2 IEC Tru-Metric - TEFC (IP55) Cast Iron Frame

Catalog Number : 01509EP3Y200L-W22

List Price : \$4,485

Notes:

Downloaded from <http://dealerselectric.com>

Generated for Model #01509EP3Y200L-W22

Performed by:

Checked:



Dealers Industrial Equipment

No.:

Date: 23-SEP-2016

DATA SHEET

Three-phase induction motor - Squirrel cage rotor

Customer :
 Product line : Three-Phase: W22 IE2 IEC Tru-Metric - TEFC (IP55) Cast Iron Frame

Frame : 200L
 Output : 20 HP
 Frequency : 60 Hz
 Poles : 8
 Full load speed : 880 rpm
 Slip : 2.22 %
 Voltage : 460 V
 Rated current : 28.0 A
 Locked rotor current : 151 A
 Locked rotor current (I_L/I_n) : 5.4
 No-load current : 14.8 A
 Full load torque : 118 lb.ft
 Locked rotor torque : 230 %
 Breakdown torque : 230 %
 Design : ---
 Insulation class : F
 Temperature rise : 80 K
 Locked rotor time : 30 s (hot)
 Service factor : 1.15
 Duty cycle : S1
 Ambient temperature : -20°C - +40°C
 Altitude : 1000 m
 Degree of Protection : IP55
 Approximate weight : 498 lb
 Moment of inertia : 10.014 sq.ft.lb
 Noise level : 56 dB(A)

	D.E.	N.D.E.	Load	Power factor	Efficiency (%)
Bearings	6312 C3	6212 C3	100%	0.74	91.0
Regreasing interval	20000 h	20000 h	75%	0.68	91.0
Grease amount	21 g	13 g	50%	0.55	90.2

Notes:
 Downloaded from <http://dealerselectric.com>
 Generated for Model #01509EP3Y200L-W22

Performed by

Checked



Dealers Industrial Equipment

No.:

Date: 23-SEP-2016

PERFORMANCE CURVES RELATED TO RATED OUTPUT

Three-phase induction motor - Squirrel cage rotor

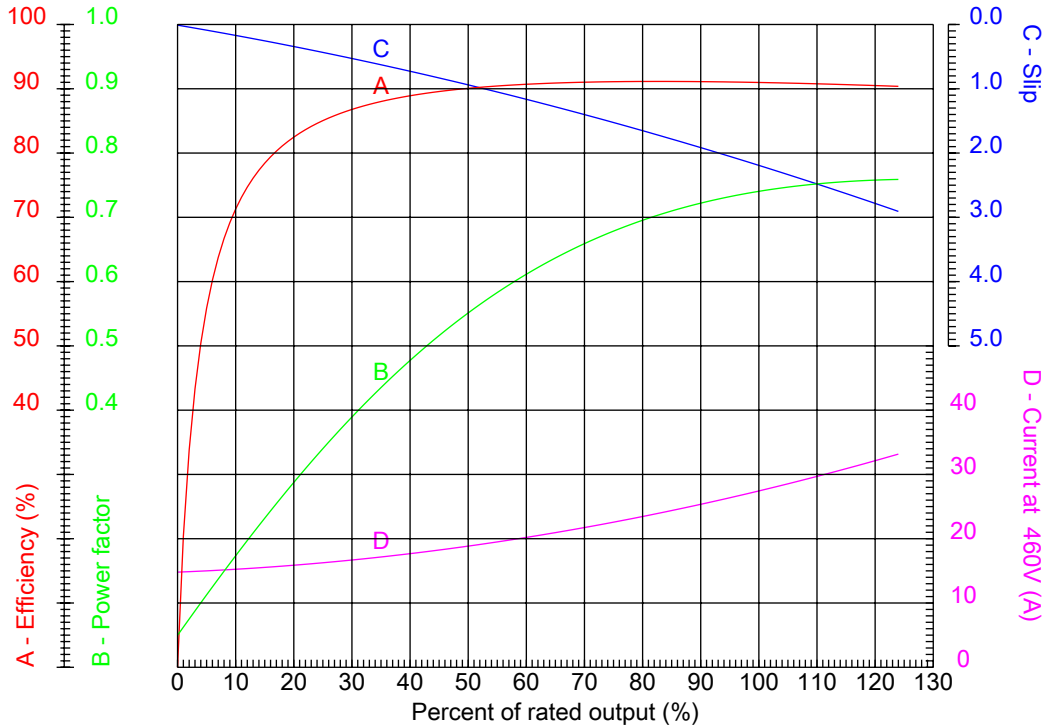

Customer :
 Product line : Three-Phase: W22 IE2 IEC Tru-Metric - TEFC (IP55) Cast Iron Frame

Frame	: 200L	Locked rotor current (I _l /I _n)	: 5.4
Output	: 20 HP	Duty cycle	: S1
Frequency	: 60 Hz	Service factor	: 1.15
Full load speed	: 880 rpm	Design	: ---
Voltage	: 460 V	Locked rotor torque	: 230 %
Rated current	: 28.0 A	Breakdown torque	: 230 %
Insulation class	: F		

Notes:
 Downloaded from <http://dealerselectric.com>
 Generated for Model #01509EP3Y200L-W22

Performed by

Checked



CHARACTERISTIC CURVES RELATED TO SPEED

Three-phase induction motor - Squirrel cage rotor

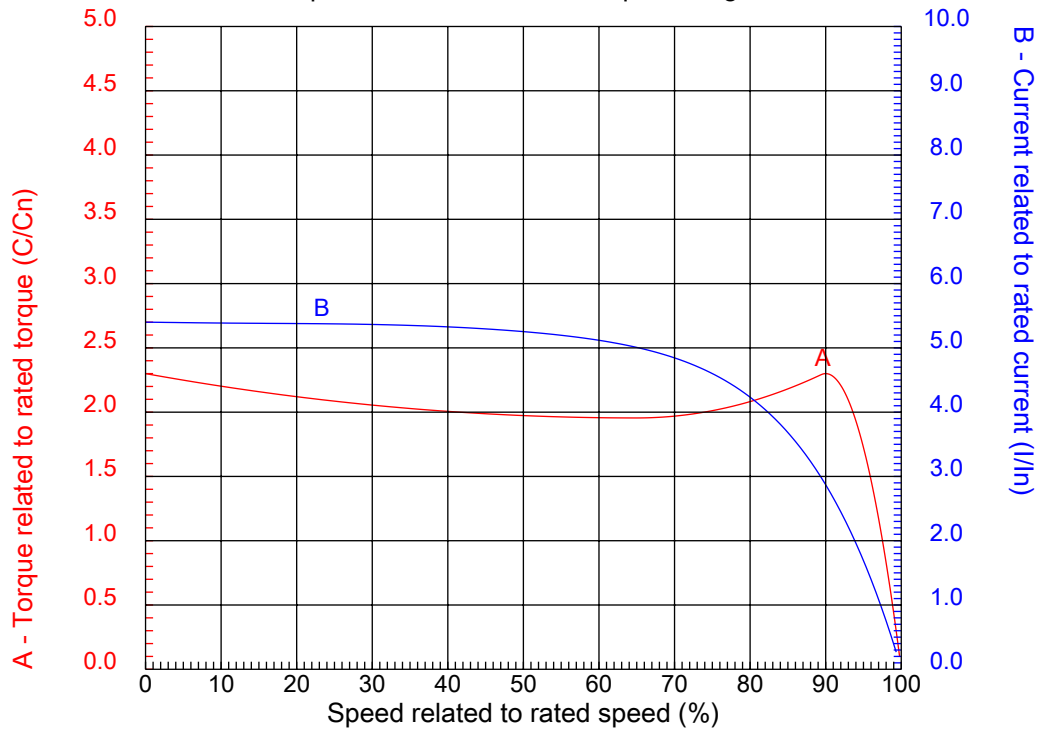

Customer :
Product line : Three-Phase: W22 IE2 IEC Tru-Metric - TEFC (IP55) Cast Iron Frame

Frame	: 200L	Locked rotor current (I _l /I _n)	: 5.4
Output	: 20 HP	Duty cycle	: S1
Frequency	: 60 Hz	Service factor	: 1.15
Full load speed	: 880 rpm	Design	: ---
Voltage	: 460 V	Locked rotor torque	: 230 %
Rated current	: 28.0 A	Breakdown torque	: 230 %
Insulation class	: F		

Notes:
Downloaded from <http://dealerselectric.com>
Generated for Model #01509EP3Y200L-W22

Performed by

Checked

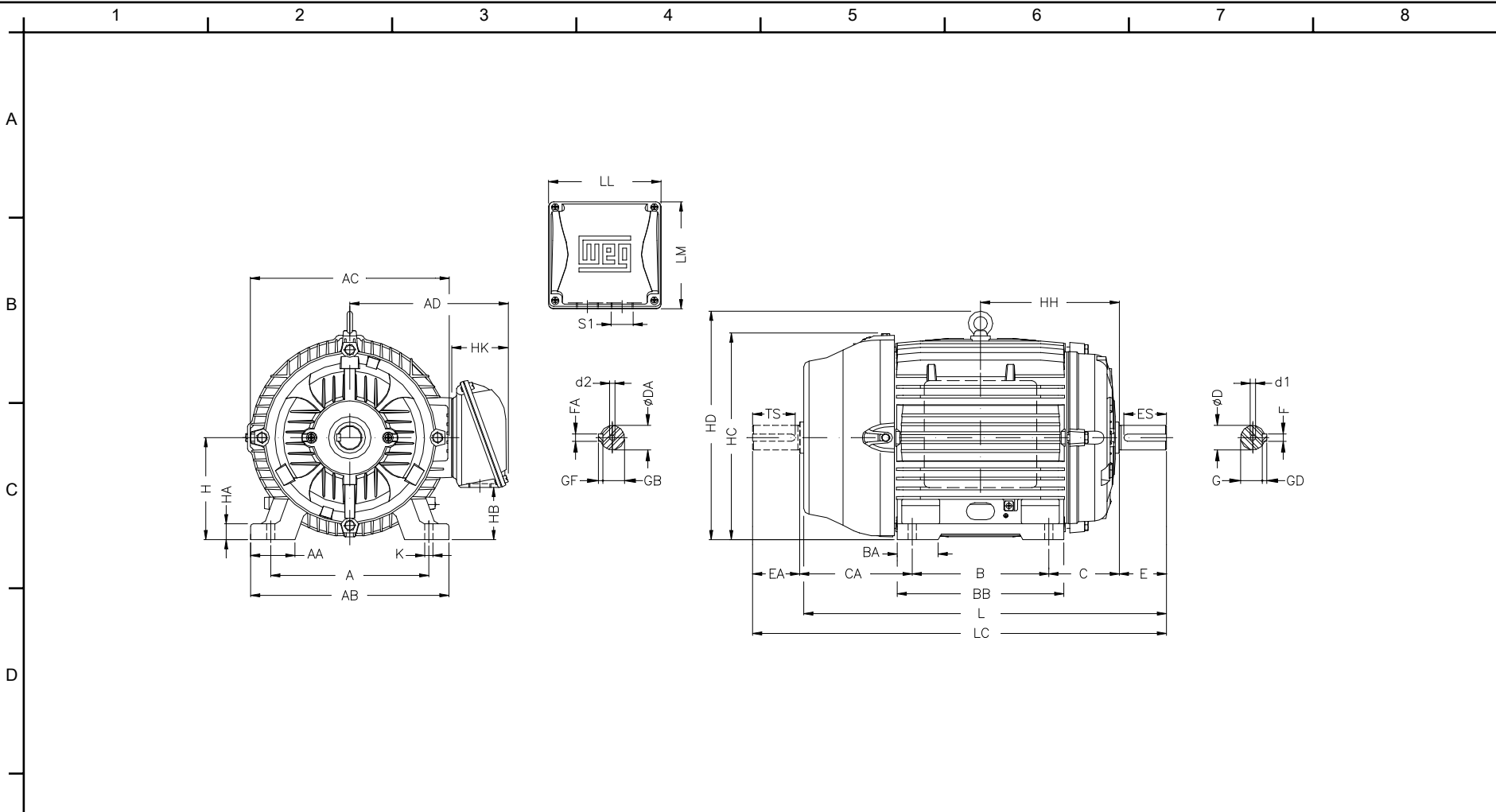

Notes: Downloaded from <http://dealerselectric.com>
Generated for Model #01509EP3Y200L-W22

E	A 318	AA 82	AB 385	AC 402	AD 319
	B 305	BA 82	BB 370	C 133	CA 222
	D 55m6	E 110	ES 80	F 16	G 49
	GD 10	DA 48k6	EA 110	TS 80	FA 14
	GB 42.5	GF 9	H 200	HA 30	HB 119
F	HC 407	HD 464	HF 218	HH 285.5	HK 119.5
	K 18.5	L 767	LC 880	LL 230	LM 220
	S1 2xM50x1.5	d1 DM20	d2 DM20		

Performed by:

Checked:

Customer:

Three-Phase: W22 IE2 IEC Tru-Metric - TEFC (IP55) Cast Iron Frame

Three-phase induction motor
Frame 200L - IP55

23-SEP-2016

