



Dealers Industrial Equipment

No.:

Date: 13-SEP-2016

Customer :

TECHNICAL PROPOSAL

Three-phase induction motor - Squirrel cage rotor

Product line : Saw Arbor Motors : Single and Double Shaft End

Catalog Number : 01018ES3ESA90LL

List Price : \$2,176

Notes:

Downloaded from <http://dealerselectric.com>

Generated for Model #01018ES3ESA90LL

Performed by:

Checked:



Dealers Industrial Equipment

No.:

Date: 13-SEP-2016

DATA SHEET

Three-phase induction motor - Squirrel cage rotor

Customer :
 Product line : Saw Arbor Motors : Single and Double Shaft End

Frame : 90L
 Output : 10 HP
 Frequency : 60 Hz
 Poles : 4
 Full load speed : 1715 rpm
 Slip : 4.72 %
 Voltage : 208-230/460 V
 Rated current : 32.5-29.4/14.7 A
 Locked rotor current : 235/117 A
 Locked rotor current (I_L/I_n) : 8.0
 No-load current : 16.3/8.13 A
 Full load torque : 30.2 lb.ft
 Locked rotor torque : 400 %
 Breakdown torque : 400 %
 Design : ---
 Insulation class : F
 Temperature rise : 80 K
 Locked rotor time : 6 s (hot)
 Service factor : 1.15
 Duty cycle : S6 50%
 Ambient temperature : -20°C - +40°C
 Altitude : 1000 m
 Degree of Protection : IP54
 Approximate weight : 178 lb
 Moment of inertia : 0.39890 sq.ft.lb
 Noise level : 51 dB(A)

	D.E.	N.D.E.
Bearings	6308 ZZ	6208 ZZ
Regreasing interval	---	---
Grease amount	---	---

Load	Power factor	Efficiency (%)
100%	0.75	85.5
75%	0.67	85.5
50%	0.54	84.5

Notes:
 Downloaded from <http://dealerselectric.com>
 Generated for Model #01018ES3ESA90LL

Performed by

Checked



Dealers Industrial Equipment

No.:

Date: 13-SEP-2016

PERFORMANCE CURVES RELATED TO RATED OUTPUT

Three-phase induction motor - Squirrel cage rotor

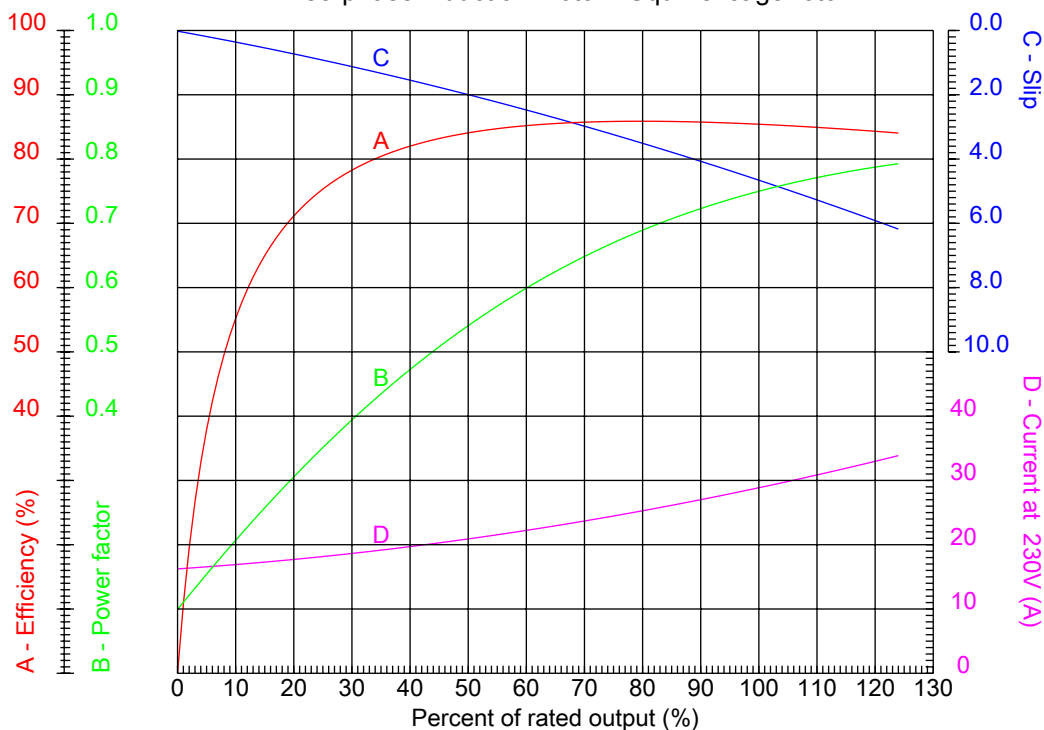

Customer :
 Product line : Saw Arbor Motors : Single and Double Shaft End

Frame	: 90L	Locked rotor current (I _l /I _n)	: 8.0
Output	: 10 HP	Duty cycle	: S6 50%
Frequency	: 60 Hz	Service factor	: 1.15
Full load speed	: 1715 rpm	Design	: ---
Voltage	: 208-230/460 V	Locked rotor torque	: 400 %
Rated current	: 32.5-29.4/14.7 A	Breakdown torque	: 400 %
Insulation class	: F		

Notes:
 Downloaded from <http://dealerselectric.com>
 Generated for Model #01018ES3ESA90LL

Performed by

Checked



Dealers Industrial Equipment

No.:

Date: 13-SEP-2016

CHARACTERISTIC CURVES RELATED TO SPEED

Three-phase induction motor - Squirrel cage rotor

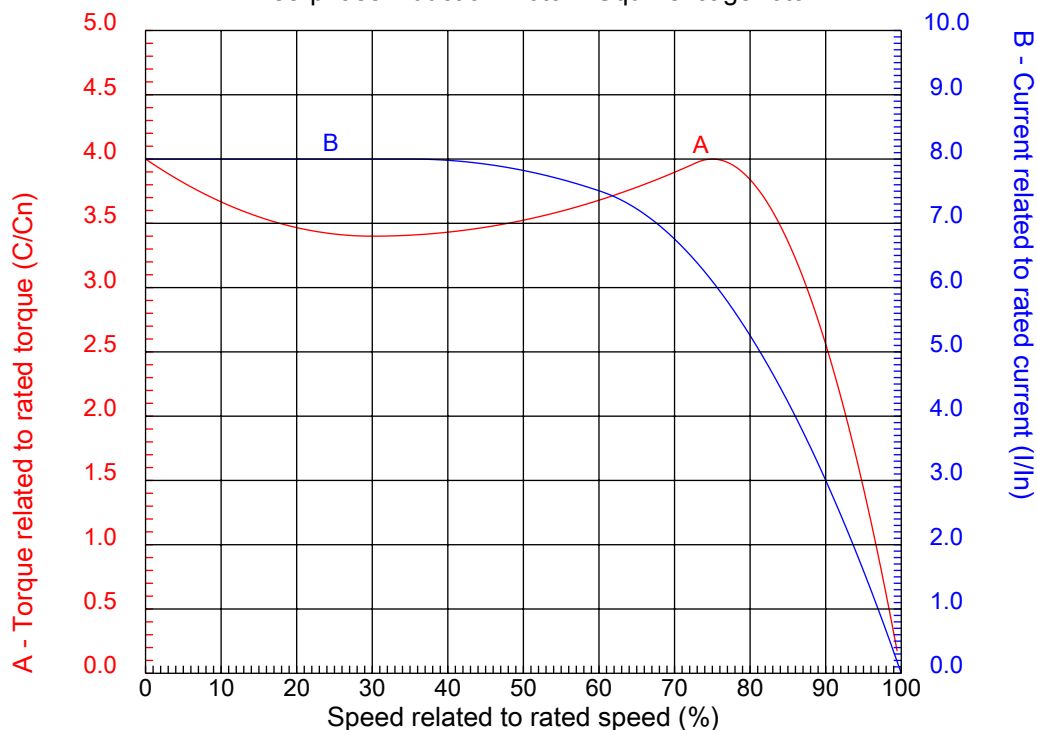

Customer :
Product line : Saw Arbor Motors : Single and Double Shaft End

Frame	: 90L	Locked rotor current (I/I _n)	: 8.0
Output	: 10 HP	Duty cycle	: S6 50%
Frequency	: 60 Hz	Service factor	: 1.15
Full load speed	: 1715 rpm	Design	: ---
Voltage	: 208-230/460 V	Locked rotor torque	: 400 %
Rated current	: 32.5-29.4/14.7 A	Breakdown torque	: 400 %
Insulation class	: F		

Notes:
Downloaded from <http://dealerselectric.com>
Generated for Model #01018ES3ESA90LL

Performed by

Checked

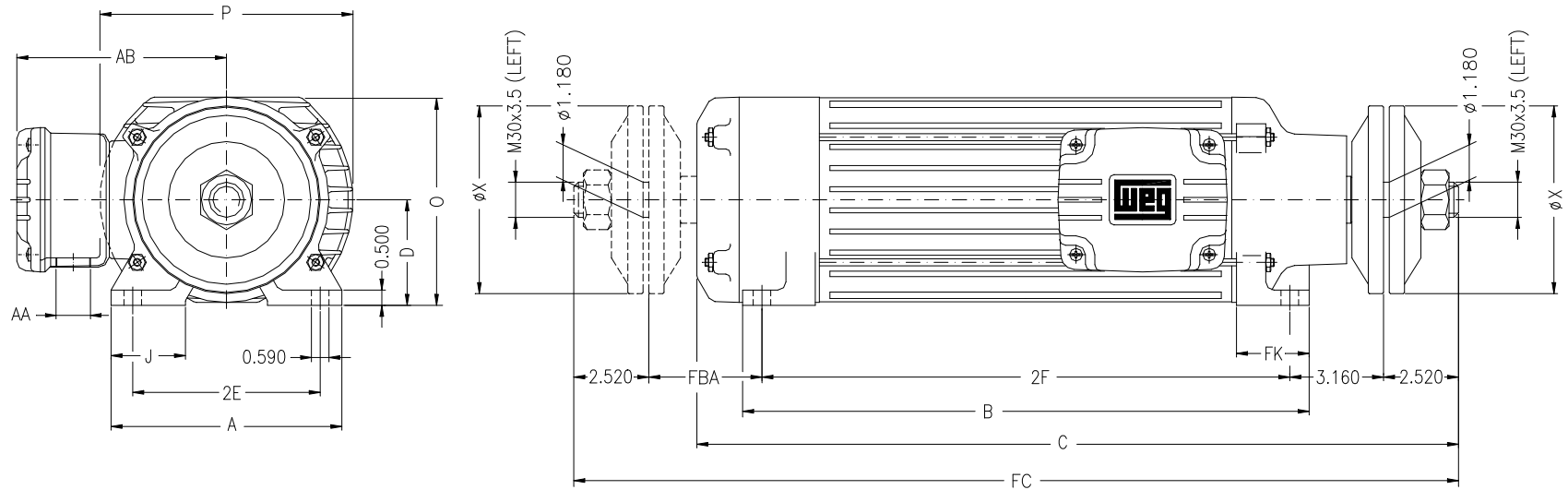

Notes: Downloaded from <http://dealerselectric.com>
 Generated for Model #01018ES3ESA90LL

Performed by:

Checked:

Customer:

Saw Arbor Motors : Single and Double Shaft End

A	B	AB	BB	BA
160	510	197	543	62
CA	L	LC	H	AA
43	672.5	758.0	90	63
HC	AC	AD	S1	
177	208	179	NPT 1"	

Three-phase induction motor
 Frame 90L - IP54

13-SEP-2016



1 2 3 4 5 6 7 8

A

B

C

D

E

F

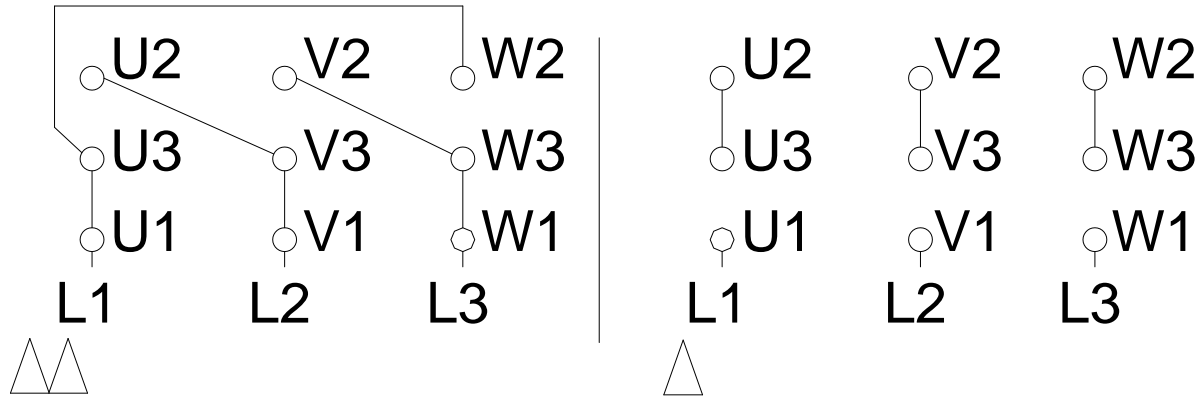

Notes: Downloaded from <http://dealerselectric.com>
Generated for Model #01018ES3ESA90LL

Performed by:

Checked:

Customer:

Saw Arbor Motors : Single and Double Shaft End

Three-phase induction motor
Frame 90L - IP54

13-SEP-2016

