



Dealers Industrial Equipment

No.:

Date: 13-SEP-2016

Customer :

TECHNICAL PROPOSAL

Three-phase induction motor - Squirrel cage rotor

Product line : W01 (Rolled Steel) General Purpose TEFC

Catalog Number : 00736ET3H213T-SG

List Price : \$1,180

Notes:

Downloaded from <http://dealerselectric.com>

Generated for Model #00736ET3H213T-SG

Performed by:

Checked:



# Dealers Industrial Equipment

No.:

Date: 13-SEP-2016

## DATA SHEET Three-phase induction motor - Squirrel cage rotor

Customer :  
 Product line : W01 (Rolled Steel) General Purpose TEFC

Frame : 213/5T  
 Output : 7.5 HP  
 Frequency : 60 Hz  
 Poles : 2  
 Full load speed : 3530 rpm  
 Slip : 1.94 %  
 Voltage : 575 V  
 Rated current : 6.94 A  
 Locked rotor current : 52.7 A  
 Locked rotor current (I<sub>L</sub>/I<sub>n</sub>) : 7.6  
 No-load current : 2.65 A  
 Full load torque : 11.0 lb.ft  
 Locked rotor torque : 260 %  
 Breakdown torque : 300 %  
 Design : B  
 Insulation class : F  
 Temperature rise : 80 K  
 Locked rotor time : 15 s (hot)  
 Service factor : 1.15  
 Duty cycle : S1  
 Ambient temperature : -20°C - +40°C  
 Altitude : 1000 m  
 Degree of Protection : IP55  
 Approximate weight : 133 lb  
 Moment of inertia : 0.54959 sq.ft.lb  
 Noise level : 70 dB(A)

	D.E.	N.D.E.
Bearings	6208 ZZ	6206 ZZ
Regreasing interval	---	---
Grease amount	---	---

Load	Power factor	Efficiency (%)
100%	0.89	89.5
75%	0.85	88.5
50%	0.76	87.5

Notes:  
 Downloaded from <http://dealerselectric.com>  
 Generated for Model #00736ET3H213T-SG

Performed by

Checked



# Dealers Industrial Equipment

No.:

Date: 13-SEP-2016

## PERFORMANCE CURVES RELATED TO RATED OUTPUT

Three-phase induction motor - Squirrel cage rotor

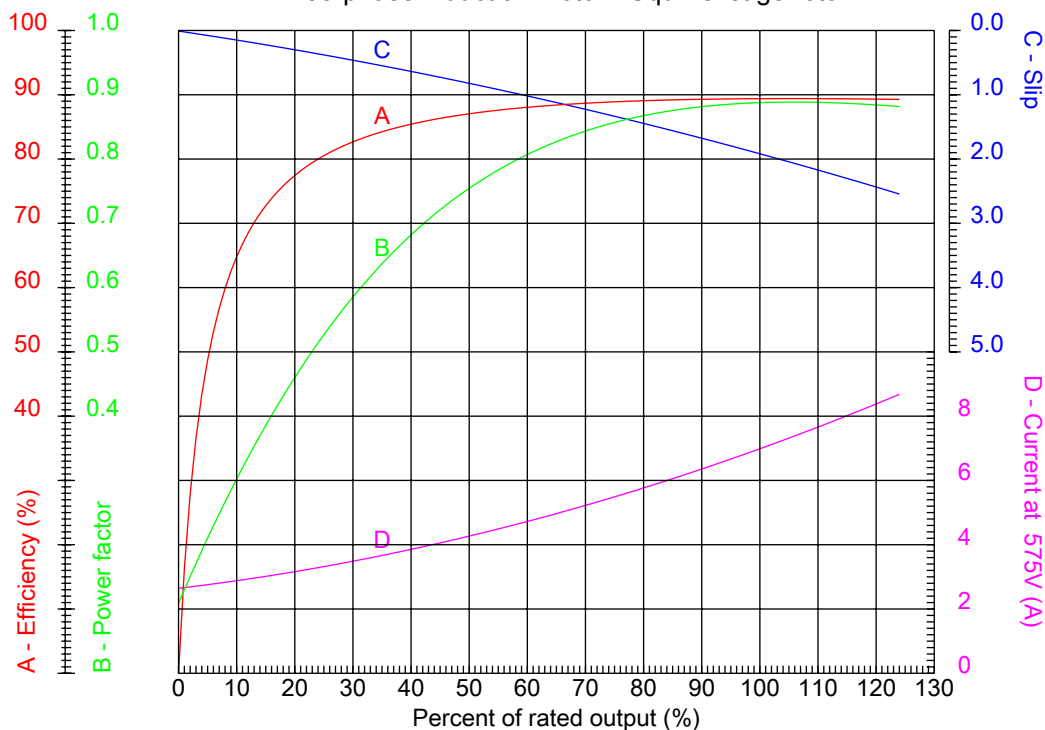

Customer :  
Product line : W01 (Rolled Steel) General Purpose TEFC

Frame	: 213/5T	Locked rotor current (I <sub>l</sub> /I <sub>n</sub> )	: 7.6
Output	: 7.5 HP	Duty cycle	: S1
Frequency	: 60 Hz	Service factor	: 1.15
Full load speed	: 3530 rpm	Design	: B
Voltage	: 575 V	Locked rotor torque	: 260 %
Rated current	: 6.94 A	Breakdown torque	: 300 %
Insulation class	: F		

Notes:  
Downloaded from <http://dealerselectric.com>  
Generated for Model #00736ET3H213T-SG

Performed by

Checked



# Dealers Industrial Equipment

No.:

Date: 13-SEP-2016

## CHARACTERISTIC CURVES RELATED TO SPEED

Three-phase induction motor - Squirrel cage rotor

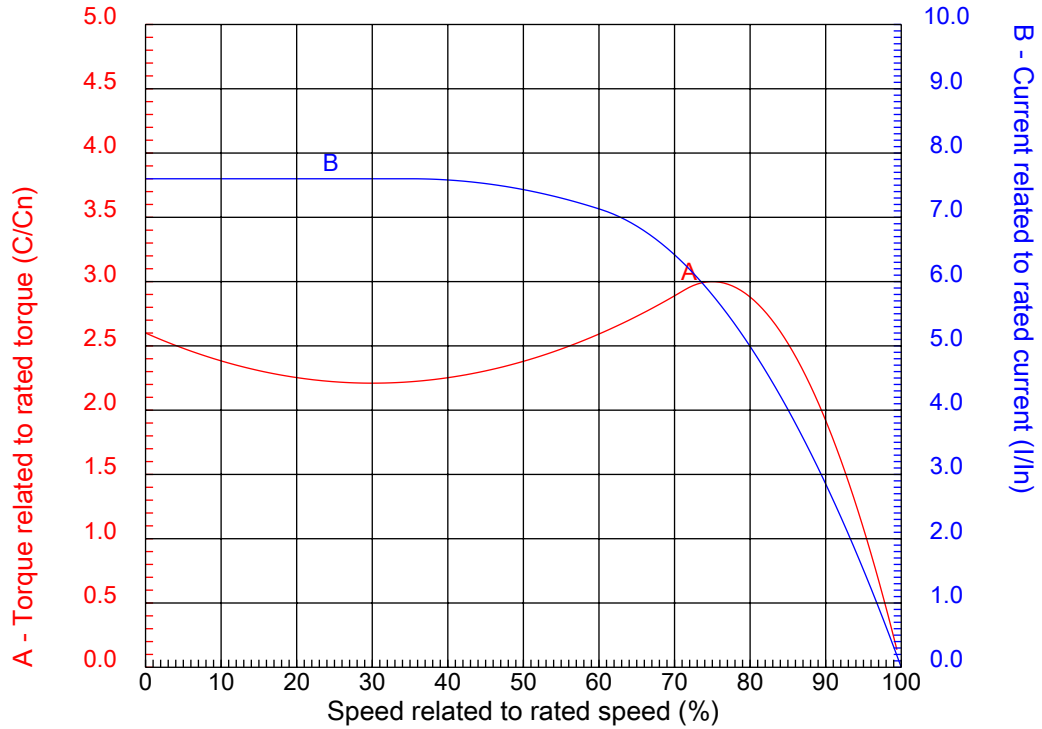

Customer :  
Product line : W01 (Rolled Steel) General Purpose TEFC

Frame	: 213/5T	Locked rotor current (I <sub>l</sub> /I <sub>n</sub> )	: 7.6
Output	: 7.5 HP	Duty cycle	: S1
Frequency	: 60 Hz	Service factor	: 1.15
Full load speed	: 3530 rpm	Design	: B
Voltage	: 575 V	Locked rotor torque	: 260 %
Rated current	: 6.94 A	Breakdown torque	: 300 %
Insulation class	: F		

Notes:  
Downloaded from <http://dealerselectric.com>  
Generated for Model #00736ET3H213T-SG

Performed by

Checked

1 2 3 4 5 6 7 8

A

B

C

D

E

F

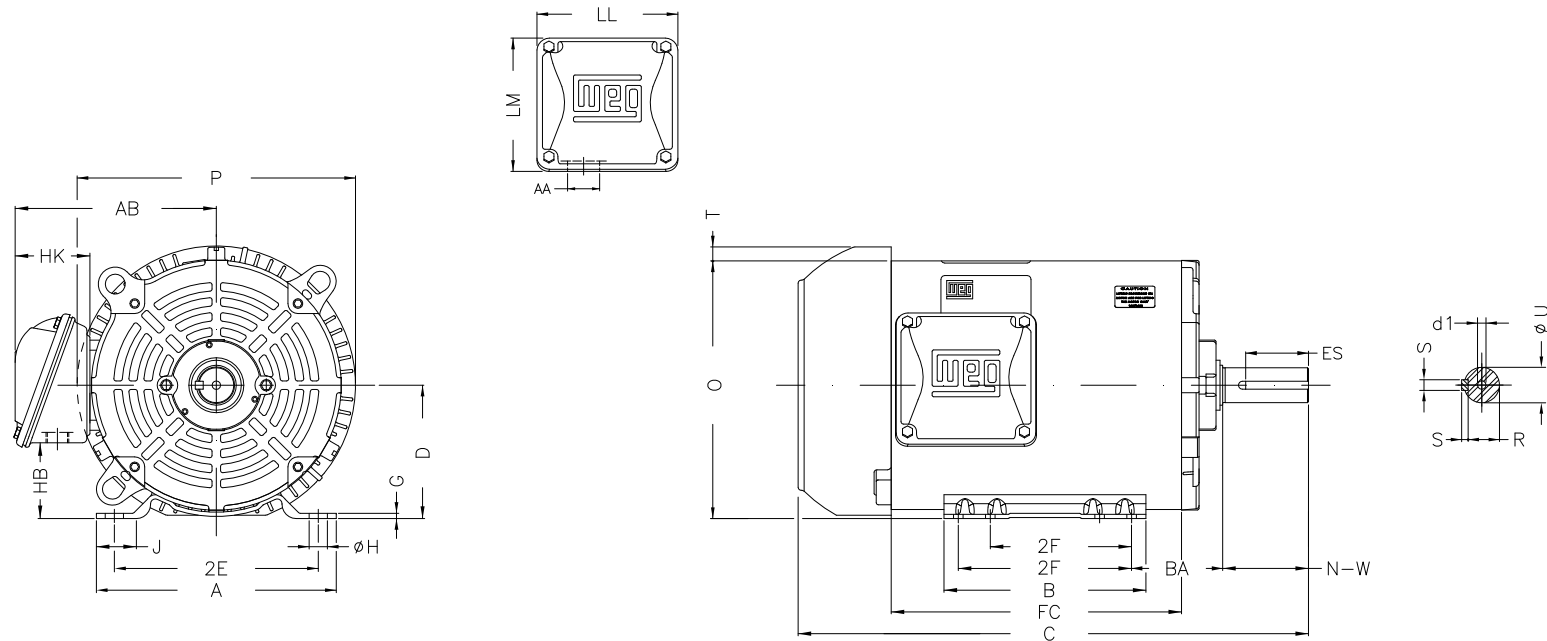

Notes: Downloaded from <http://dealerselectric.com>  
Generated for Model #00736ET3H213T-SG

Performed by:

Checked:

Customer:

W01 (Rolled Steel) General Purpose TEFC

Three-phase induction motor  
Frame 213/5T - IP55

13-SEP-2016



P	AB	J	2E	A
10.965	7.973	1.575	8.500	9.449
H	G	HB	HK	T
0.406	0.167	2.982	3.022	0.761
O	FC	2F	B	C
10.144	11.417	5.500/7.000	7.953	20.079
BA	N-W	ES	d1	S
3.500	3.380	2.480	A4	0.313
U	AA	depth	R	LL
1.375	1.377"	0.313	1.203	5.551
LM	BB	D	CH	
5.250	0.761	5.250	1.929	

1 2 3 4 5 6 7 8

A

B

C

D

E

F

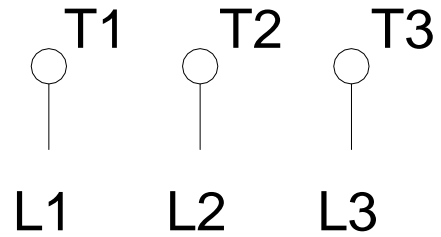

Notes: Downloaded from <http://dealerselectric.com>  
Generated for Model #00736ET3H213T-SG

Performed by:

Checked:

Customer:

W01 (Rolled Steel) General Purpose TEFC

Three-phase induction motor  
Frame 213/5T - IP55

13-SEP-2016

