



# Dealers Industrial Equipment

No.:

Date: 13-SEP-2016

Customer :

## TECHNICAL PROPOSAL

### Three-phase induction motor - Squirrel cage rotor

Product line : Three-Phase : Rolled Steel Motor - NEMA Premium Efficiency

Catalog Number : 00736ET3ERS213TC

List Price : \$>(discontinued)</span>

#### Notes:

Downloaded from <http://dealerselectric.com>

Generated for Model #00736ET3ERS213TC

Performed by:

Checked:



# Dealers Industrial Equipment

No.:

Date: 13-SEP-2016

## DATA SHEET Three-phase induction motor - Squirrel cage rotor

Customer :  
 Product line : Three-Phase : Rolled Steel Motor - NEMA Premium Efficiency

Frame : 213T  
 Output : 7.5 HP  
 Frequency : 60 Hz  
 Poles : 2  
 Full load speed : 3510 rpm  
 Slip : 2.50 %  
 Voltage : 208-230/460 V  
 Rated current : 19.8-17.1/8.57 A  
 Locked rotor current : 120/60.0 A  
 Locked rotor current (I<sub>L</sub>/I<sub>n</sub>) : 7.0  
 No-load current : 5.00/2.50 A  
 Full load torque : 11.1 lb.ft  
 Locked rotor torque : 220 %  
 Breakdown torque : 300 %  
 Design : B  
 Insulation class : F  
 Temperature rise : 80 K  
 Locked rotor time : 23 s (hot)  
 Service factor : 1.15  
 Duty cycle : S1  
 Ambient temperature : -20°C - +40°C  
 Altitude : 1000 m  
 Degree of Protection : IP55  
 Approximate weight : 121 lb  
 Moment of inertia : 0.57664 sq.ft.lb  
 Noise level : ---

	D.E.	N.D.E.
Bearings	6208 ZZ	6206 ZZ
Regreasing interval	---	---
Grease amount	---	---

Load	Power factor	Efficiency (%)
100%	0.90	89.5
75%	0.87	88.5
50%	0.81	85.5

Notes:  
 Downloaded from <http://dealerselectric.com>  
 Generated for Model #00736ET3ERS213TC

Performed by

Checked



# Dealers Industrial Equipment

No.:

Date: 13-SEP-2016

## PERFORMANCE CURVES RELATED TO RATED OUTPUT

Three-phase induction motor - Squirrel cage rotor

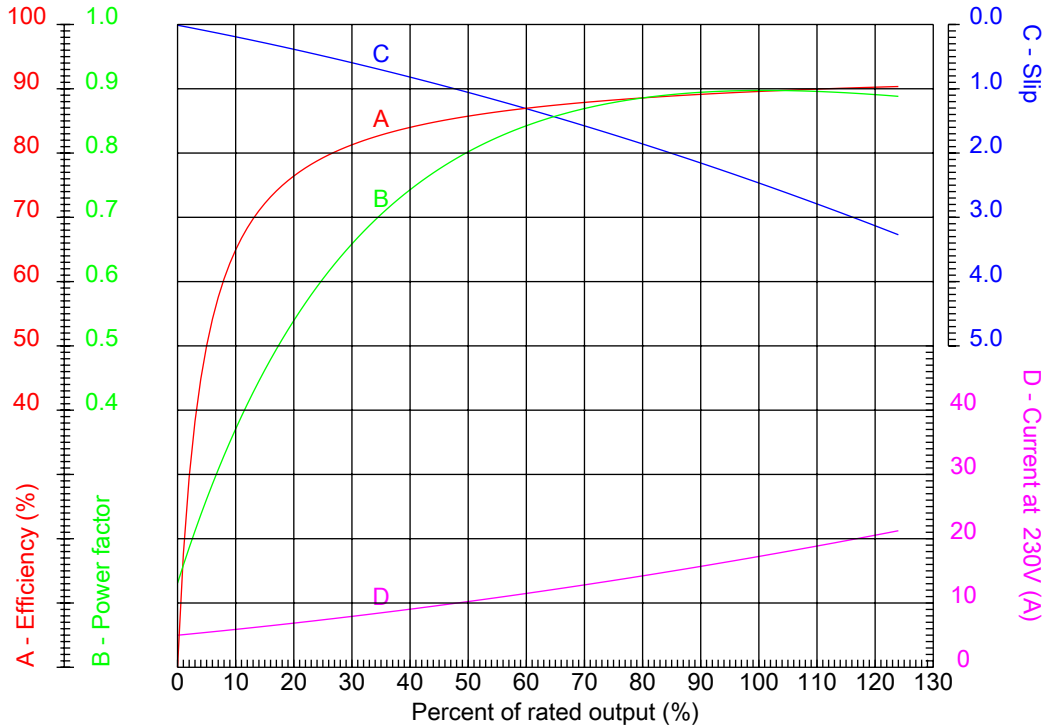

Customer :  
 Product line : Three-Phase : Rolled Steel Motor - NEMA Premium Efficiency

Frame	: 213T	Locked rotor current (I <sub>L</sub> /I <sub>n</sub> )	: 7.0
Output	: 7.5 HP	Duty cycle	: S1
Frequency	: 60 Hz	Service factor	: 1.15
Full load speed	: 3510 rpm	Design	: B
Voltage	: 208-230/460 V	Locked rotor torque	: 220 %
Rated current	: 19.8-17.1/8.57 A	Breakdown torque	: 300 %
Insulation class	: F		

Notes:  
 Downloaded from <http://dealerselectric.com>  
 Generated for Model #00736ET3ERS213TC

Performed by

Checked



# Dealers Industrial Equipment

No.:

Date: 13-SEP-2016

## CHARACTERISTIC CURVES RELATED TO SPEED

Three-phase induction motor - Squirrel cage rotor

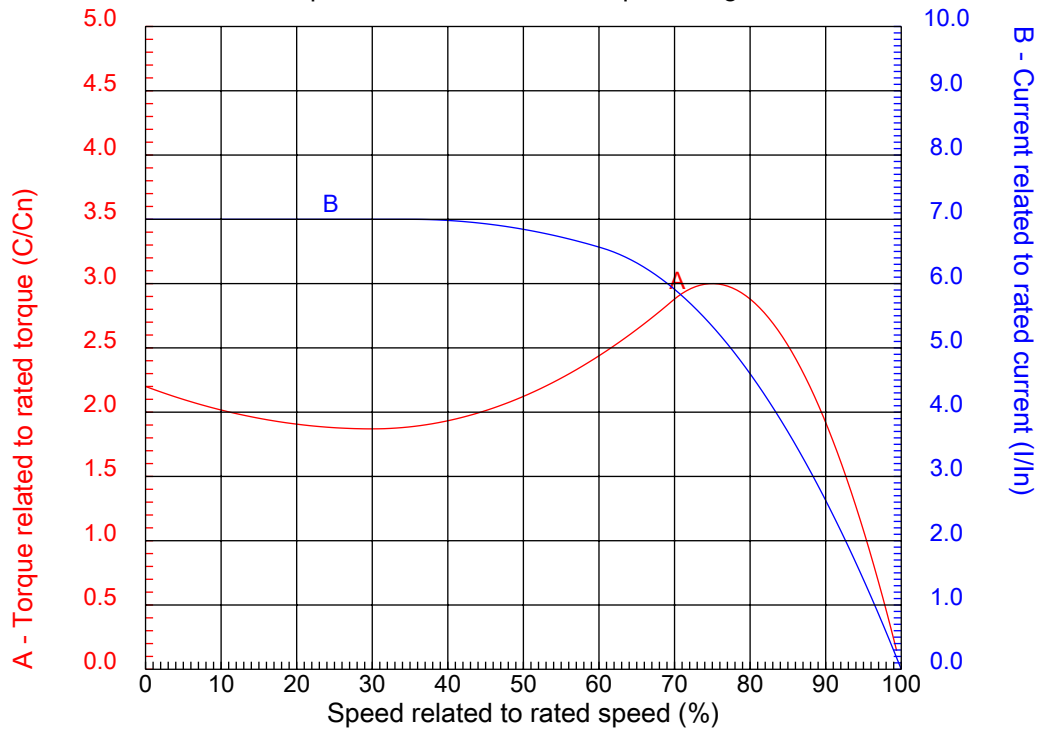

Customer :  
Product line : Three-Phase : Rolled Steel Motor - NEMA Premium Efficiency

Frame	: 213T	Locked rotor current (I <sub>l</sub> /I <sub>n</sub> )	: 7.0
Output	: 7.5 HP	Duty cycle	: S1
Frequency	: 60 Hz	Service factor	: 1.15
Full load speed	: 3510 rpm	Design	: B
Voltage	: 208-230/460 V	Locked rotor torque	: 220 %
Rated current	: 19.8-17.1/8.57 A	Breakdown torque	: 300 %
Insulation class	: F		

Notes:  
Downloaded from <http://dealerselectric.com>  
Generated for Model #00736ET3ERS213TC

Performed by

Checked

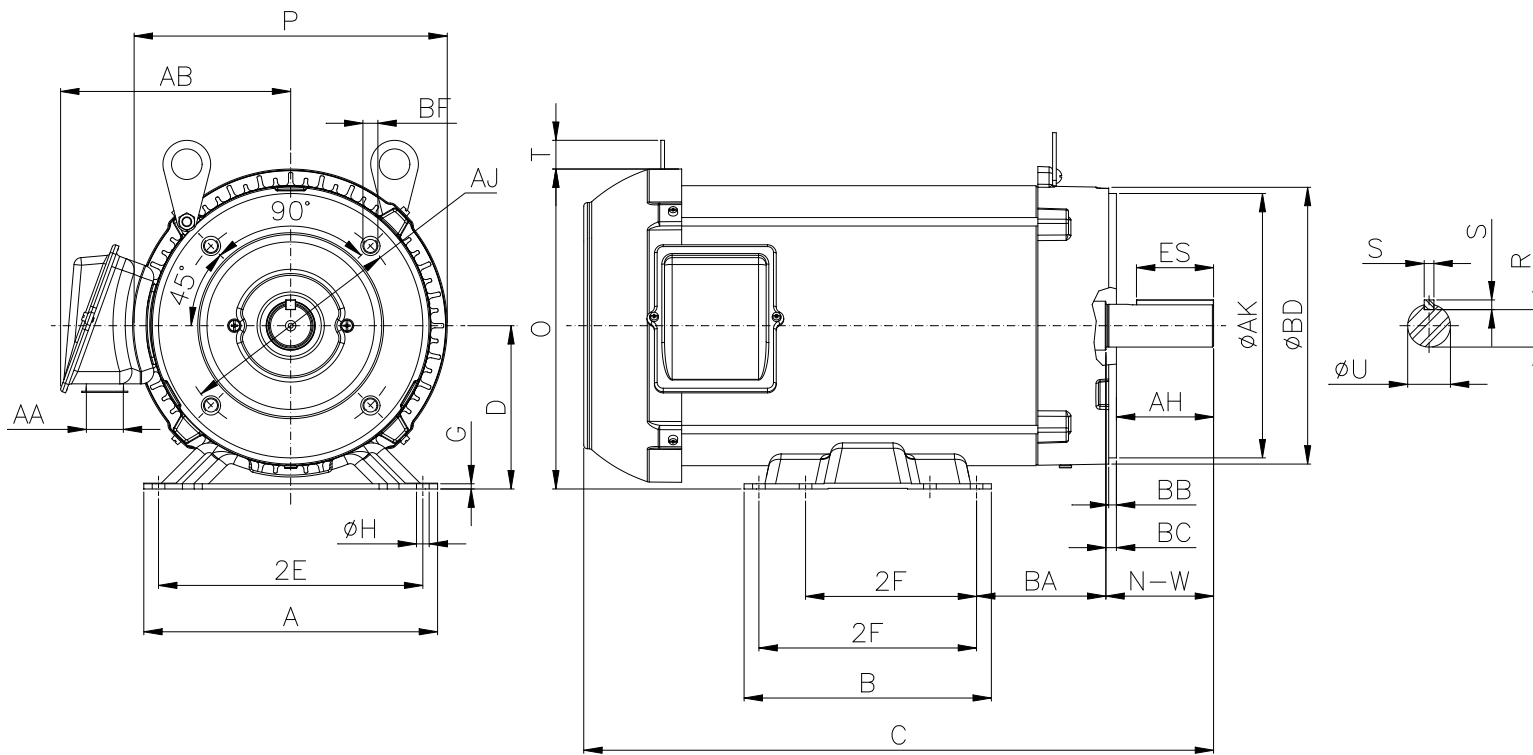

Notes: Downloaded from <http://dealerselectric.com>  
 Generated for Model #00736ET3ERS213TC

Performed by:

Checked:

Customer:

Three-Phase : Rolled Steel Motor - NEMA Premium Efficiency

Three-phase induction motor  
 Frame 213T - IP55

13-SEP-2016



2E 8.500	A 9.449	P 10.071	AB 7.398	2F 5.500/7.000
B 7.953	BA 4.250	U 1.375	N-W 3.375	ES 2.480
S 0.313	R 1.203	depth 0.313	D 5.250	G 0.167
O 10.285	T 0.923	H 0.406	C 20.257	d1 A 4
d2 A 4	Flange FC-184	AJ 7.250	AK 8.500	BD 8.875
BF UNC 1/2"x13	BB 0.250	BC 0.250	AH 3.125	

1 2 3 4 5 6 7 8

# LOW VOLTAGE

# HIGH VOLTAGE

A  
B  
C  
D  
E  
F

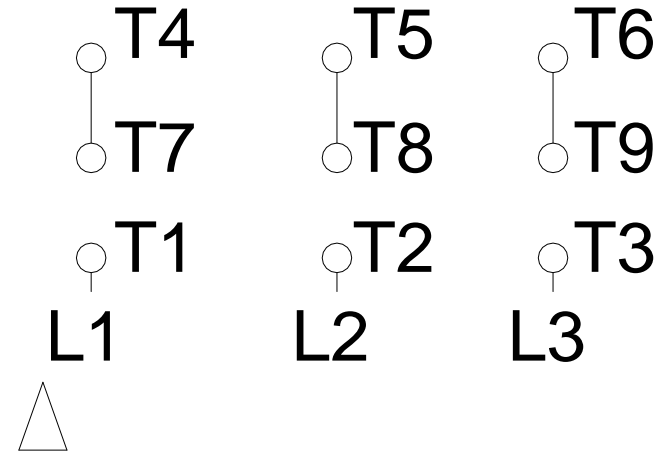
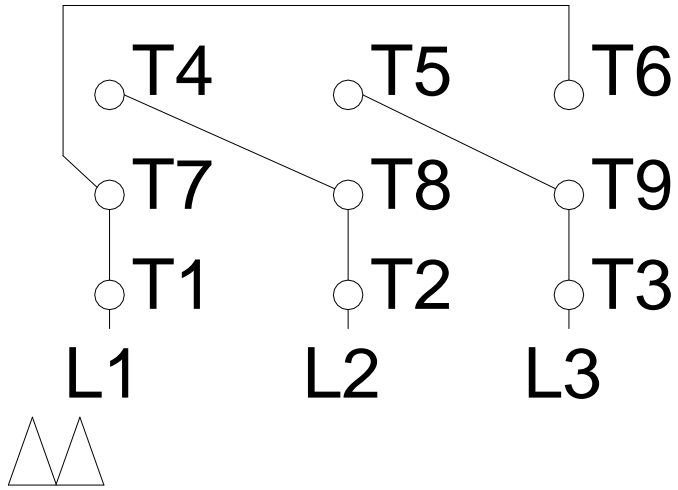

Notes: Downloaded from <a href="http://dealerselectric.com">http://dealerselectric.com</a> Generated for Model #00736ET3ERS213TC		
Performed by:		
Checked:		
Customer:		
Three-Phase : Rolled Steel Motor - NEMA Premium Efficiency		
Three-phase induction motor Frame 213T - IP55	13-SEP-2016	