



# Dealers Industrial Equipment

No.:

Date: 13-SEP-2016

Customer :

## TECHNICAL PROPOSAL

### Three-phase induction motor - Squirrel cage rotor

Product line : W22 Brake Motor - NEMA Premium Efficiency

Catalog Number : 00518ET3EBM184T-W22

List Price : \$2,291

#### Notes:

Downloaded from <http://dealerselectric.com>

Generated for Model #00518ET3EBM184T-W22

Performed by:

Checked:



# Dealers Industrial Equipment

No.:

Date: 13-SEP-2016

## DATA SHEET Three-phase induction motor - Squirrel cage rotor

Customer :  
 Product line : W22 Brake Motor - NEMA Premium Efficiency

Frame : 182/4T  
 Output : 5 HP  
 Frequency : 60 Hz  
 Poles : 4  
 Full load speed : 1755 rpm  
 Slip : 2.50 %  
 Voltage : 208-230/460 V  
 Rated current : 14.3-12.9/6.45 A  
 Locked rotor current : 96.8/48.4 A  
 Locked rotor current (I<sub>L</sub>/I<sub>n</sub>) : 7.5  
 No-load current : 6.40/3.20 A  
 Full load torque : 14.8 lb.ft  
 Locked rotor torque : 230 %  
 Breakdown torque : 320 %  
 Design : B  
 Insulation class : F  
 Temperature rise : 80 K  
 Locked rotor time : 15 s (hot)  
 Service factor : 1.25  
 Duty cycle : S1  
 Ambient temperature : -20°C - +40°C  
 Altitude : 1000 m  
 Degree of Protection : IP55  
 Approximate weight : 108 lb  
 Moment of inertia : 0.40033 sq.ft.lb  
 Noise level : 56 dB(A)

	D.E.	N.D.E.	Load	Power factor	Efficiency (%)
Bearings	6207 ZZ	6206 ZZ	100%	0.80	89.5
Regreasing interval	---	---	75%	0.74	89.5
Grease amount	---	---	50%	0.62	88.5

Notes:  
 Downloaded from <http://dealerselectric.com>  
 Generated for Model #00518ET3EBM184T-W22

Performed by

Checked



# Dealers Industrial Equipment

No.:

Date: 13-SEP-2016

## PERFORMANCE CURVES RELATED TO RATED OUTPUT

Three-phase induction motor - Squirrel cage rotor

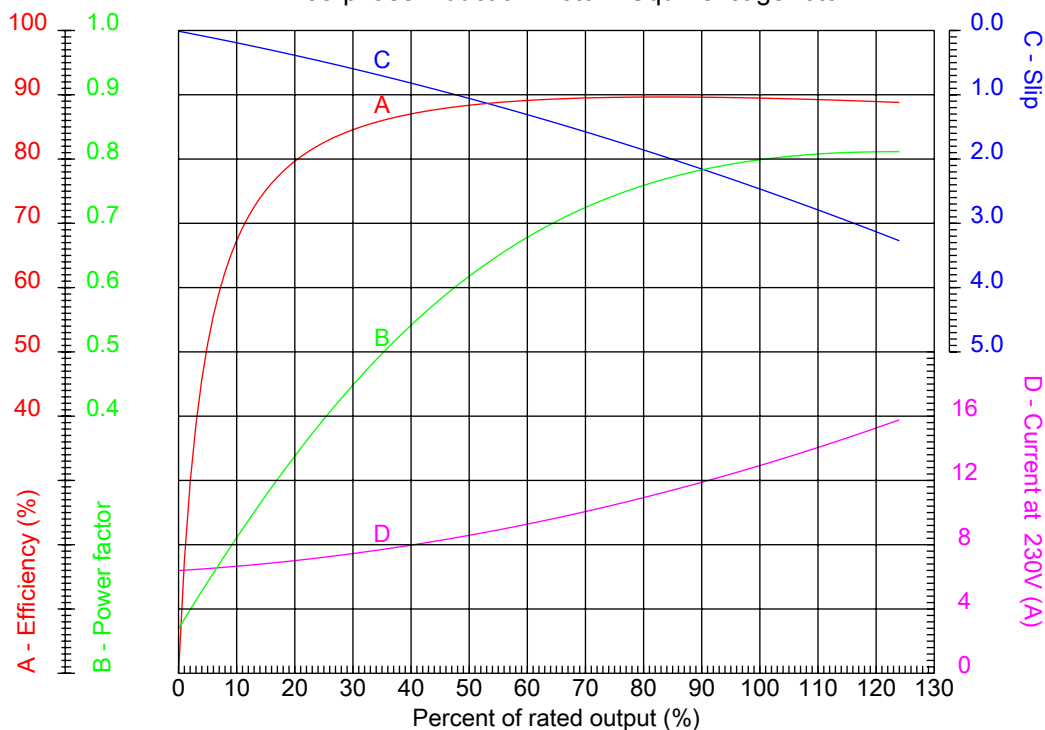

Customer :  
Product line : W22 Brake Motor - NEMA Premium Efficiency

Frame	: 182/4T	Locked rotor current (I <sub>l</sub> /I <sub>n</sub> )	: 7.5
Output	: 5 HP	Duty cycle	: S1
Frequency	: 60 Hz	Service factor	: 1.25
Full load speed	: 1755 rpm	Design	: B
Voltage	: 208-230/460 V	Locked rotor torque	: 230 %
Rated current	: 14.3-12.9/6.45 A	Breakdown torque	: 320 %
Insulation class	: F		

Notes:  
Downloaded from <http://dealerselectric.com>  
Generated for Model #00518ET3EBM184T-W22

Performed by

Checked



# Dealers Industrial Equipment

No.:

Date: 13-SEP-2016

## CHARACTERISTIC CURVES RELATED TO SPEED

Three-phase induction motor - Squirrel cage rotor

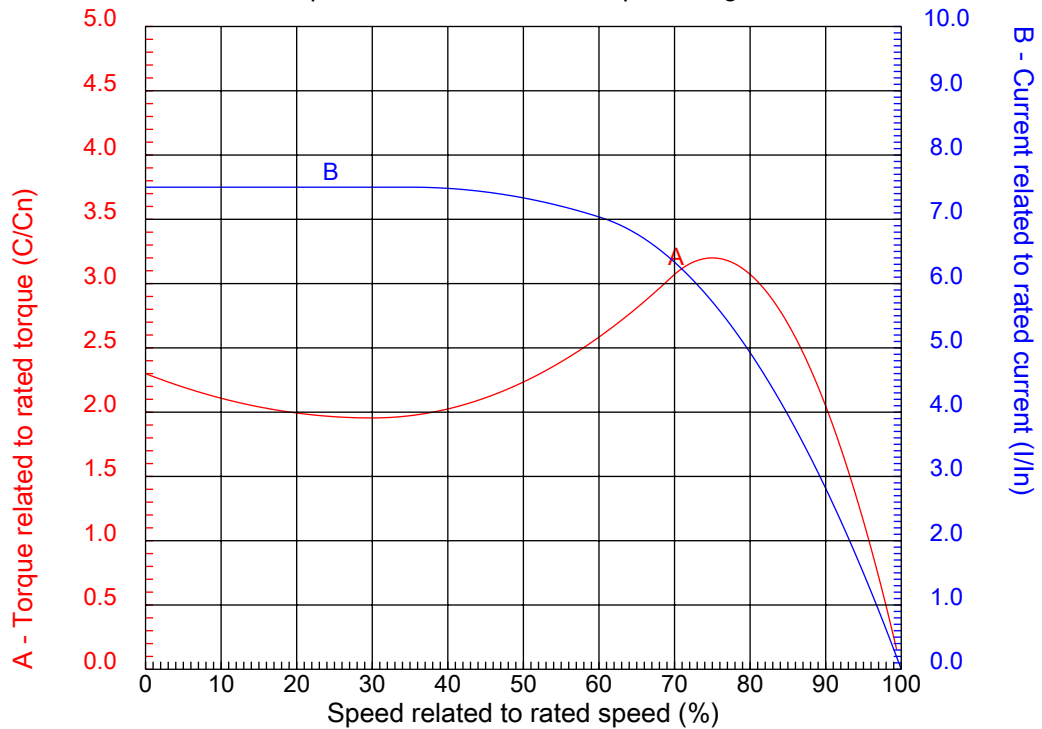

Customer :  
Product line : W22 Brake Motor - NEMA Premium Efficiency

Frame	: 182/4T	Locked rotor current (I <sub>l</sub> /I <sub>n</sub> )	: 7.5
Output	: 5 HP	Duty cycle	: S1
Frequency	: 60 Hz	Service factor	: 1.25
Full load speed	: 1755 rpm	Design	: B
Voltage	: 208-230/460 V	Locked rotor torque	: 230 %
Rated current	: 14.3-12.9/6.45 A	Breakdown torque	: 320 %
Insulation class	: F		

Notes:  
Downloaded from <http://dealerselectric.com>  
Generated for Model #00518ET3EBM184T-W22

Performed by

Checked

1 2 3 4 5 6 7 8

A

B

C

D

E

F

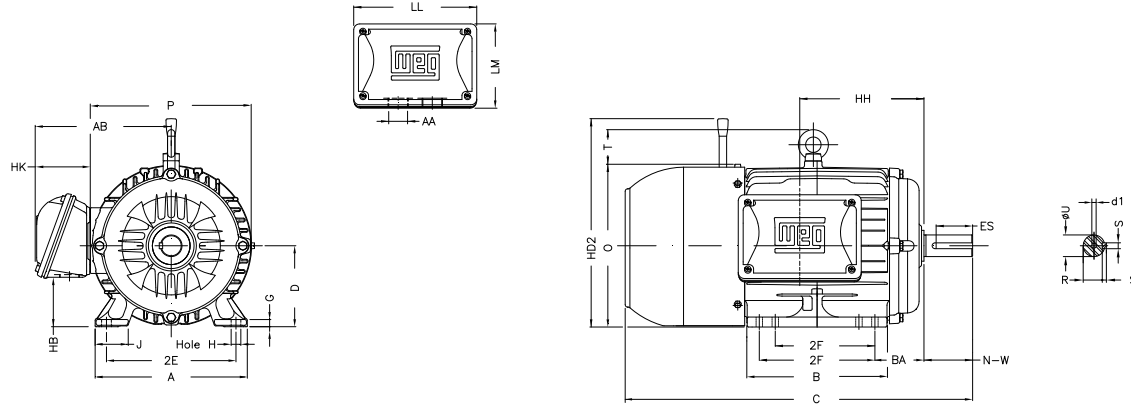

Notes: Downloaded from <http://dealerselectric.com>  
Generated for Model #00518ET3EBM184T-W22

Performed by:

Checked:

Customer:

W22 Brake Motor - NEMA Premium Efficiency

2E 7.500	J 1.614	A 8.661	P 8.740	AB 7.513
2F 4.500/5.500	B 6.969	BA 2.750	U 1.125	N-W 2.750
ES 1.969	S 0.250	R 0.984	D 4.500	G 0.394
HB 2.216	O 9.343	HF 4.500	HH 5.500	HK 3.117
H 0.406	C 19.314	LL 6.575	LM 5.246	AA NPT 1"
HD' 7.728	d1 A 4	HD2 12.138	T 1.772	

Three-phase induction motor  
Frame 182/4T - IP55

13-SEP-2016



1 2 3 4 5 6 7 8

# LOW VOLTAGE

# HIGH VOLTAGE

A  
B  
C  
D  
E  
F

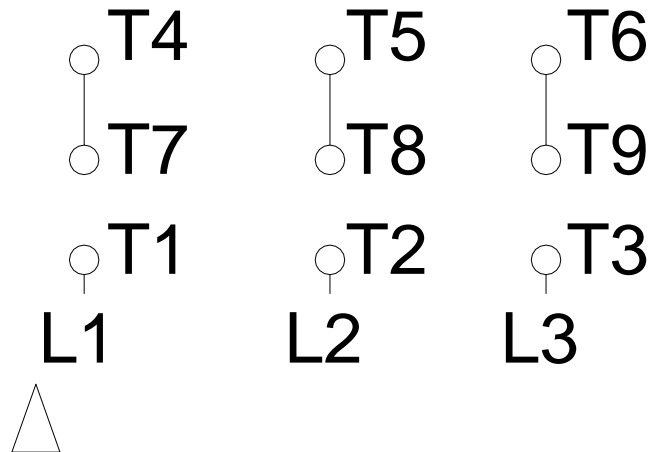

Notes: Downloaded from <http://dealerselectric.com>  
 Generated for Model #00518ET3EBM184T-W22

Performed by:

Checked:

Customer:

W22 Brake Motor - NEMA Premium Efficiency

Three-phase induction motor  
 Frame 182/4T - IP55

13-SEP-2016

