



Dealers Industrial Equipment

No.:

Date: 13-SEP-2016

Customer :

TECHNICAL PROPOSAL

Three-phase induction motor - Squirrel cage rotor

Product line : Three-Phase: W22 IE3 IEC Tru-Metric - TEFC (IP55) Cast Iron Frame

Catalog Number : 00418ET3Y112M-W22

List Price : \$694

Notes:

Downloaded from <http://dealerselectric.com>

Generated for Model #00418ET3Y112M-W22

Performed by:

Checked:



Dealers Industrial Equipment

No.:

Date: 13-SEP-2016

DATA SHEET Three-phase induction motor - Squirrel cage rotor

Customer :
Product line : Three-Phase: W22 IE3 IEC Tru-Metric - TEFC (IP55) Cast Iron Frame

Frame : 112M
Output : 5.5 HP
Frequency : 60 Hz
Poles : 4
Full load speed : 1755 rpm
Slip : 2.50 %
Voltage : 460 V
Rated current : 7.28 A
Locked rotor current : 58.2 A
Locked rotor current (I_L/I_n) : 8.0
No-load current : 4.25 A
Full load torque : 16.2 lb.ft
Locked rotor torque : 250 %
Breakdown torque : 350 %
Design : ---
Insulation class : F
Temperature rise : 80 K
Locked rotor time : 19 s (hot)
Service factor : 1.25
Duty cycle : S1
Ambient temperature : -20°C - +40°C
Altitude : 1000 m
Degree of Protection : IP55
Approximate weight : 97 lb
Moment of inertia : 0.43117 sq.ft.lb
Noise level : 56 dB(A)

	D.E.	N.D.E.
Bearings	6207 ZZ	6206 ZZ
Regreasing interval	---	---
Grease amount	---	---

Load	Power factor	Efficiency (%)
100%	0.77	89.5
75%	0.70	89.5
50%	0.58	87.5

Notes:
Downloaded from <http://dealerselectric.com>
Generated for Model #00418ET3Y112M-W22

Performed by

Checked



Dealers Industrial Equipment

No.:

Date: 13-SEP-2016

PERFORMANCE CURVES RELATED TO RATED OUTPUT

Three-phase induction motor - Squirrel cage rotor

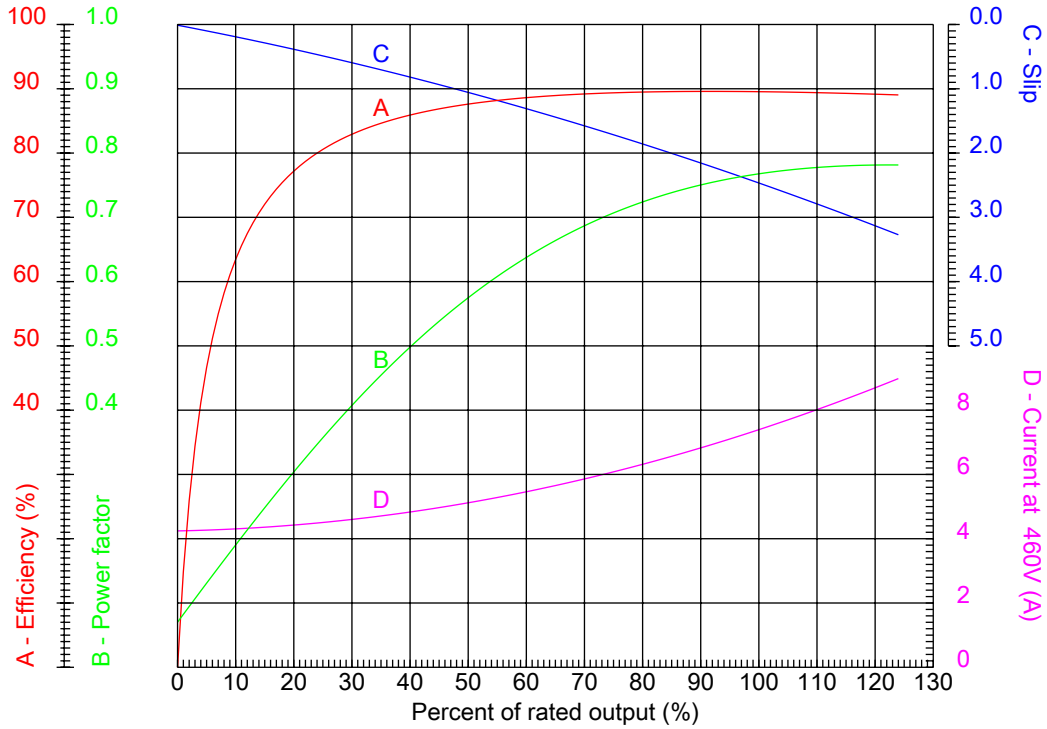

Customer :
 Product line : Three-Phase: W22 IE3 IEC Tru-Metric - TEFC (IP55) Cast Iron Frame

Frame	: 112M	Locked rotor current (I _l /I _n)	: 8.0
Output	: 5.5 HP	Duty cycle	: S1
Frequency	: 60 Hz	Service factor	: 1.25
Full load speed	: 1755 rpm	Design	: ---
Voltage	: 460 V	Locked rotor torque	: 250 %
Rated current	: 7.28 A	Breakdown torque	: 350 %
Insulation class	: F		

Notes:
 Downloaded from <http://dealerselectric.com>
 Generated for Model #00418ET3Y112M-W22

Performed by

Checked



Dealers Industrial Equipment

No.:

Date: 13-SEP-2016

CHARACTERISTIC CURVES RELATED TO SPEED

Three-phase induction motor - Squirrel cage rotor

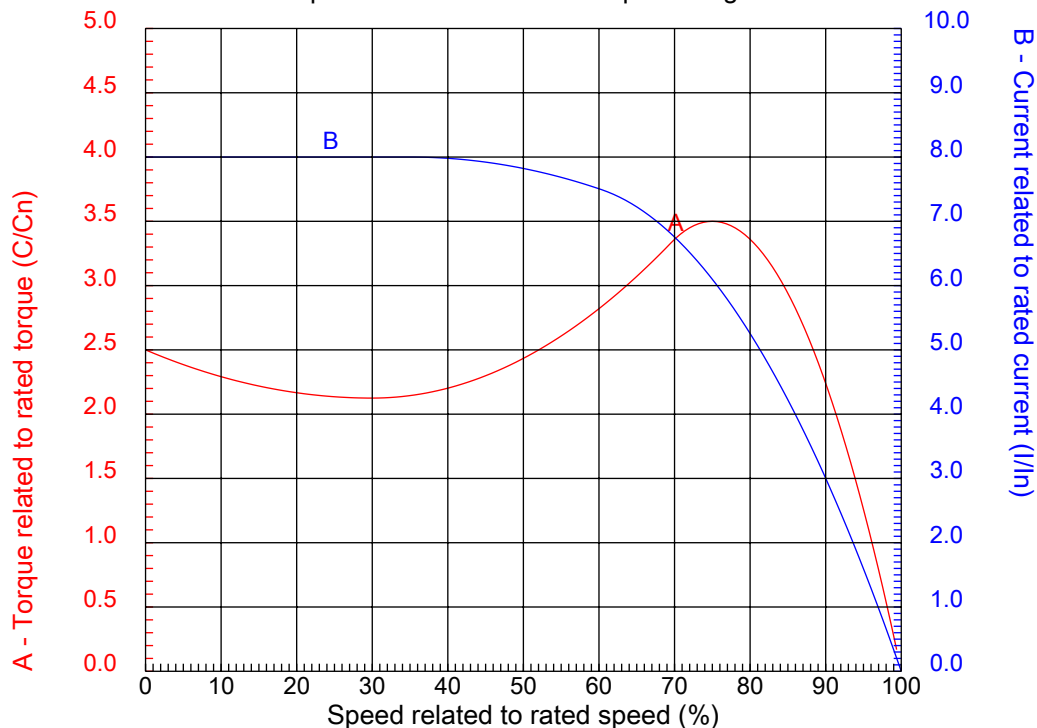

Customer :
Product line : Three-Phase: W22 IE3 IEC Tru-Metric - TEFC (IP55) Cast Iron Frame

Frame	: 112M	Locked rotor current (I _l /I _n)	: 8.0
Output	: 5.5 HP	Duty cycle	: S1
Frequency	: 60 Hz	Service factor	: 1.25
Full load speed	: 1755 rpm	Design	: ---
Voltage	: 460 V	Locked rotor torque	: 250 %
Rated current	: 7.28 A	Breakdown torque	: 350 %
Insulation class	: F		

Notes:
Downloaded from <http://dealerselectric.com>
Generated for Model #00418ET3Y112M-W22

Performed by

Checked

1 2 3 4 5 6 7 8

A
B
C
D
E
F

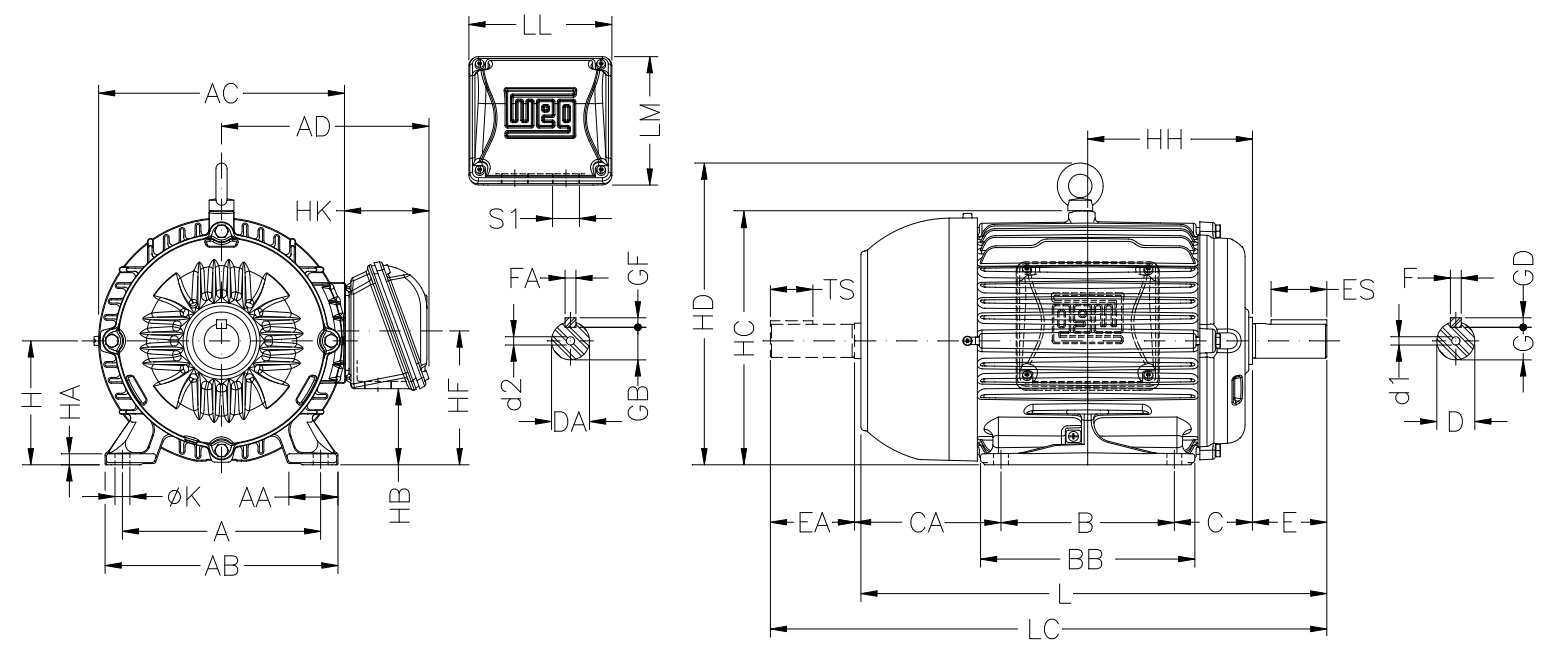

Notes: Downloaded from <http://dealerselectric.com>
Generated for Model #00418ET3Y112M-W22

A	AA	AB	AC	AD
190	40.5	220	227	192
B	BB	C	CA	D
140	177	70	128	28j6
E	ES	F	G	GD
60	45	8	24	7
DA	EA	TS	FA	GB
24j6	50	36	8	20
GF	H	HA	HC	HD
7	112	10	235	280
K	L	LC	S1	d1
12	394	448	2xM32x1.5	DM10
d2				
DM8				

Performed by:

Checked:

Customer:

Three-Phase: W22 IE3 IEC Tru-Metric - TEFC (IP55) Cast Iron Frame

Three-phase induction motor
Frame 112M - IP55

13-SEP-2016



LOW VOLTAGE

HIGH VOLTAGE

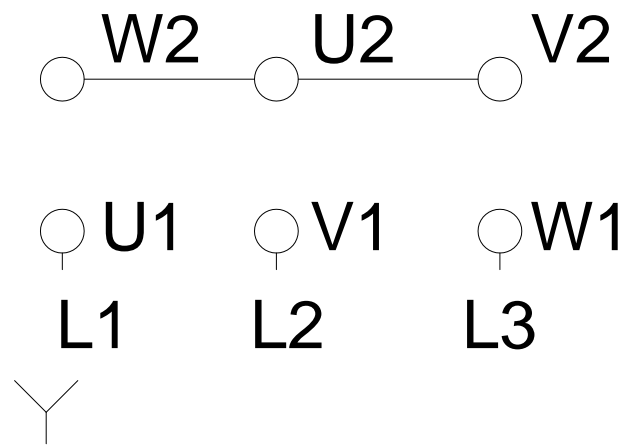
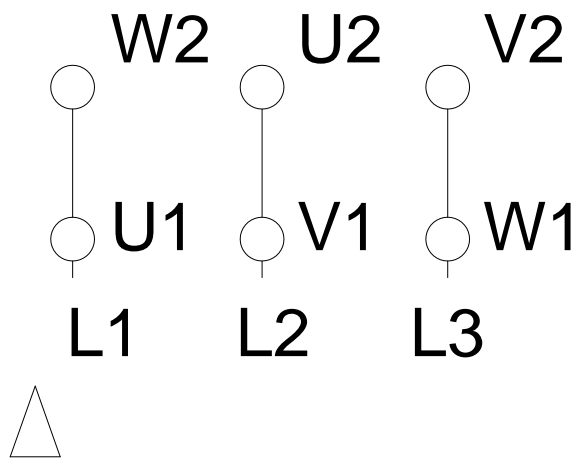

Notes: Downloaded from <http://dealerselectric.com>
Generated for Model #00418ET3Y112M-W22

Performed by:

Checked:

Customer:

Three-Phase: W22 IE3 IEC Tru-Metric - TEFC (IP55) Cast Iron Frame

Three-phase induction motor
Frame 112M - IP55

13-SEP-2016

