



Dealers Industrial Equipment

No.:

Date: 12-SEP-2016

Customer :

TECHNICAL PROPOSAL

Three-phase induction motor - Squirrel cage rotor

Product line : Three Phase: W01 (Rolled Steel) - TEFC - Standard Efficiency

Catalog Number : 00336ES3E56CFL-S

List Price : \$507

Notes:

Downloaded from <http://dealerselectric.com>

Generated for Model #00336ES3E56CFL-S

Performed by:

Checked:



# Dealers Industrial Equipment

No.:

Date: 12-SEP-2016

## DATA SHEET Three-phase induction motor - Squirrel cage rotor

Customer :  
 Product line : Three Phase: W01 (Rolled Steel) - TEFC - Standard Efficiency

Frame : 56H  
 Output : 3 HP  
 Frequency : 60 Hz  
 Poles : 2  
 Full load speed : 3480 rpm  
 Slip : 3.33 %  
 Voltage : 208-230/460 V  
 Rated current : 8.32-7.52/3.76 A  
 Locked rotor current : 63.9/32.0 A  
 Locked rotor current (I<sub>L</sub>/I<sub>n</sub>) : 8.5  
 No-load current : 2.80/1.40 A  
 Full load torque : 4.47 lb.ft  
 Locked rotor torque : 270 %  
 Breakdown torque : 280 %  
 Design : A  
 Insulation class : F  
 Temperature rise : 80 K  
 Locked rotor time : 6 s (hot)  
 Service factor : 1.15  
 Duty cycle : S1  
 Ambient temperature : -20°C - +40°C  
 Altitude : 1000 m  
 Degree of Protection : IP55  
 Approximate weight : 38 lb  
 Moment of inertia : 0.12790 sq.ft.lb  
 Noise level : 68 dB(A)

	D.E.	N.D.E.
Bearings	6204 ZZ	6202 ZZ
Regreasing interval	---	---
Grease amount	---	---

Load	Power factor	Efficiency (%)
100%	0.90	81.5
75%	0.86	81.5
50%	0.76	80.0

Notes:  
 Downloaded from <http://dealerselectric.com>  
 Generated for Model #00336ES3E56CFL-S

Performed by

Checked



# Dealers Industrial Equipment

No.:

Date: 12-SEP-2016

## PERFORMANCE CURVES RELATED TO RATED OUTPUT

Three-phase induction motor - Squirrel cage rotor

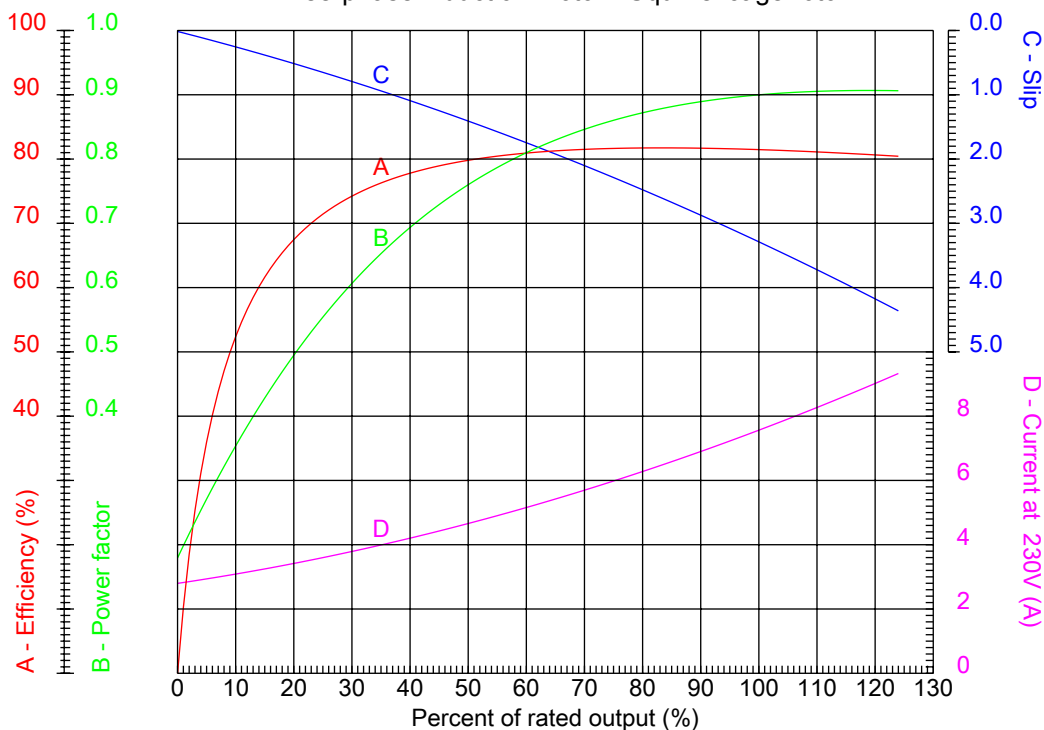

Customer :  
 Product line : Three Phase: W01 (Rolled Steel) - TEFC - Standard Efficiency

Frame	: 56H	Locked rotor current (I <sub>l</sub> /I <sub>n</sub> )	: 8.5
Output	: 3 HP	Duty cycle	: S1
Frequency	: 60 Hz	Service factor	: 1.15
Full load speed	: 3480 rpm	Design	: A
Voltage	: 208-230/460 V	Locked rotor torque	: 270 %
Rated current	: 8.32-7.52/3.76 A	Breakdown torque	: 280 %
Insulation class	: F		

Notes:  
 Downloaded from <http://dealerselectric.com>  
 Generated for Model #00336ES3E56CFL-S

Performed by

Checked



# Dealers Industrial Equipment

No.:

Date: 12-SEP-2016

## CHARACTERISTIC CURVES RELATED TO SPEED

Three-phase induction motor - Squirrel cage rotor

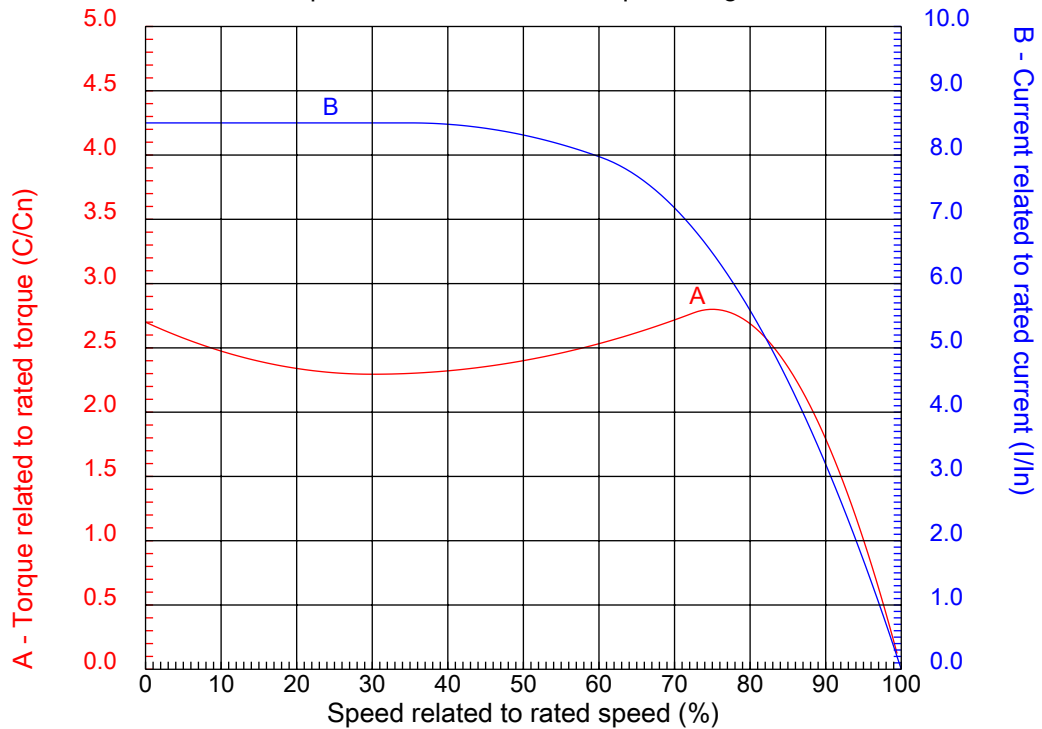

Customer :  
Product line : Three Phase: W01 (Rolled Steel) - TEFC - Standard Efficiency

Frame	: 56H	Locked rotor current (I <sub>l</sub> /I <sub>n</sub> )	: 8.5
Output	: 3 HP	Duty cycle	: S1
Frequency	: 60 Hz	Service factor	: 1.15
Full load speed	: 3480 rpm	Design	: A
Voltage	: 208-230/460 V	Locked rotor torque	: 270 %
Rated current	: 8.32-7.52/3.76 A	Breakdown torque	: 280 %
Insulation class	: F		

Notes:  
Downloaded from <http://dealerselectric.com>  
Generated for Model #00336ES3E56CFL-S

Performed by

Checked

1 2 3 4 5 6 7 8

A

B

C

D

E

F

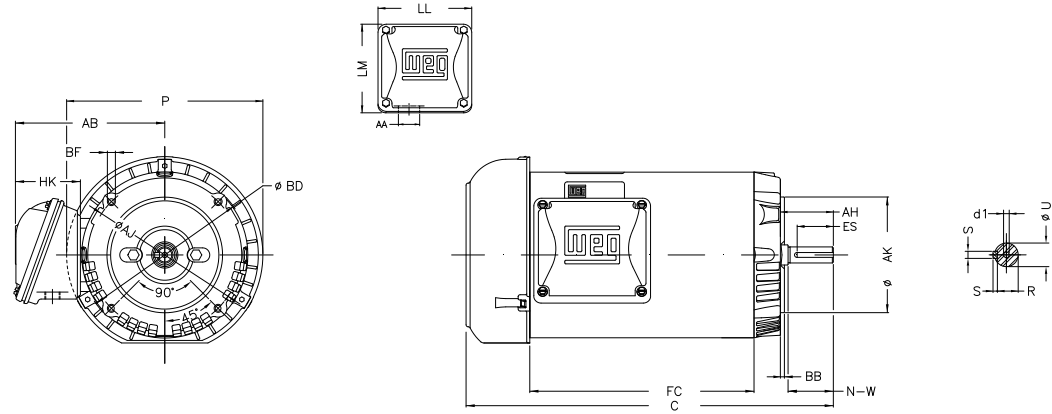

Notes: Downloaded from <http://dealerselectric.com>  
Generated for Model #00336ES3E56CFL-S

Performed by:

Checked:

Customer:

Three Phase: W01 (Rolled Steel) - TEFC - Standard Efficiency

P	AB	HK	FC	C
7.638	5.882	2.638	8.268	13.898
N-W	ES	d1	S	U
1.874	1.417	A 3.15	0.187	0.625
AA	depth	R	LL	LM
0.881"	0.187	0.517	4.543	4.106
Flange	AJ	AK	BD	BF
FC-149	5.874	4.500	6.450	UNC 3/8"x16-2B
BB	AH			
0.157	2.062			

Three-phase induction motor  
Frame 56H - IP55

12-SEP-2016

