



Dealers Industrial Equipment

No.:

Date: 12-SEP-2016

Customer :

TECHNICAL PROPOSAL

Three-phase induction motor - Squirrel cage rotor

Product line : Three Phase: W01 (Rolled Steel) - TEFC - Standard Efficiency

Catalog Number : 00118ES3E56-S

List Price : \$321

Notes:

Downloaded from <http://dealerselectric.com>

Generated for Model #00118ES3E56-S

Performed by:

Checked:



# Dealers Industrial Equipment

No.:

Date: 12-SEP-2016

## DATA SHEET Three-phase induction motor - Squirrel cage rotor

Customer :  
 Product line : Three Phase: W01 (Rolled Steel) - TEFC - Standard Efficiency

Frame : 56  
 Output : 1 HP  
 Frequency : 60 Hz  
 Poles : 4  
 Full load speed : 1760 rpm  
 Slip : 2.22 %  
 Voltage : 208-230/460 V  
 Rated current : 3.67-3.32/1.66 A  
 Locked rotor current : 25.6/12.8 A  
 Locked rotor current (I<sub>L</sub>/I<sub>n</sub>) : 7.7  
 No-load current : 2.40/1.20 A  
 Full load torque : 2.94 lb.ft  
 Locked rotor torque : 270 %  
 Breakdown torque : 300 %  
 Design : A  
 Insulation class : F  
 Temperature rise : 80 K  
 Locked rotor time : 12 s (hot)  
 Service factor : 1.15  
 Duty cycle : S1  
 Ambient temperature : -20°C - +40°C  
 Altitude : 1000 m  
 Degree of Protection : IP55  
 Approximate weight : 27 lb  
 Moment of inertia : 0.08424 sq.ft.lb  
 Noise level : 52 dB(A)

	D.E.	N.D.E.
Bearings	6204 ZZ	6202 ZZ
Regreasing interval	---	---
Grease amount	---	---

Load	Power factor	Efficiency (%)
100%	0.71	80.0
75%	0.62	78.5
50%	0.48	74.0

Notes:  
 Downloaded from <http://dealerselectric.com>  
 Generated for Model #00118ES3E56-S

Performed by

Checked



# Dealers Industrial Equipment

No.:

Date: 12-SEP-2016

## PERFORMANCE CURVES RELATED TO RATED OUTPUT

Three-phase induction motor - Squirrel cage rotor

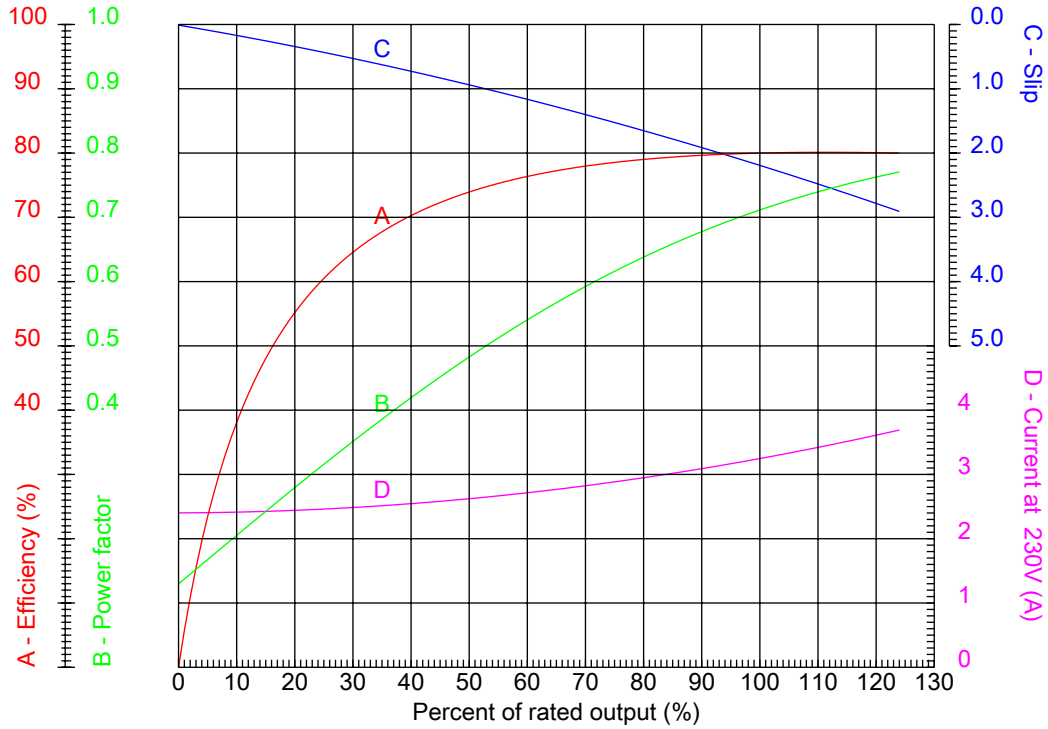

Customer :  
 Product line : Three Phase: W01 (Rolled Steel) - TEFC - Standard Efficiency

Frame	: 56	Locked rotor current (I <sub>L</sub> /I <sub>n</sub> )	: 7.7
Output	: 1 HP	Duty cycle	: S1
Frequency	: 60 Hz	Service factor	: 1.15
Full load speed	: 1760 rpm	Design	: A
Voltage	: 208-230/460 V	Locked rotor torque	: 270 %
Rated current	: 3.67-3.32/1.66 A	Breakdown torque	: 300 %
Insulation class	: F		

Notes:  
 Downloaded from <http://dealerselectric.com>  
 Generated for Model #00118ES3E56-S

Performed by

Checked



# Dealers Industrial Equipment

No.:

Date: 12-SEP-2016

## CHARACTERISTIC CURVES RELATED TO SPEED

Three-phase induction motor - Squirrel cage rotor

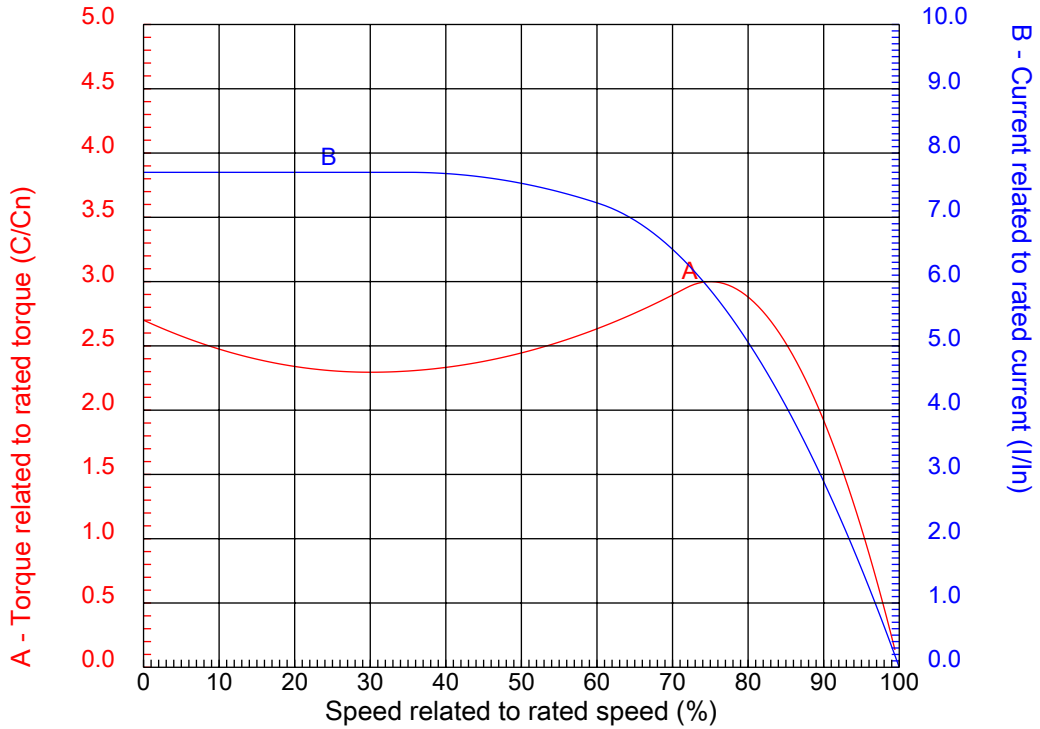

Customer :  
Product line : Three Phase: W01 (Rolled Steel) - TEFC - Standard Efficiency

Frame	: 56	Locked rotor current (I <sub>l</sub> /I <sub>n</sub> )	: 7.7
Output	: 1 HP	Duty cycle	: S1
Frequency	: 60 Hz	Service factor	: 1.15
Full load speed	: 1760 rpm	Design	: A
Voltage	: 208-230/460 V	Locked rotor torque	: 270 %
Rated current	: 3.67-3.32/1.66 A	Breakdown torque	: 300 %
Insulation class	: F		

Notes:  
Downloaded from <http://dealerselectric.com>  
Generated for Model #00118ES3E56-S

Performed by

Checked

1 2 3 4 5 6 7 8

A  
B  
C  
D  
E  
F

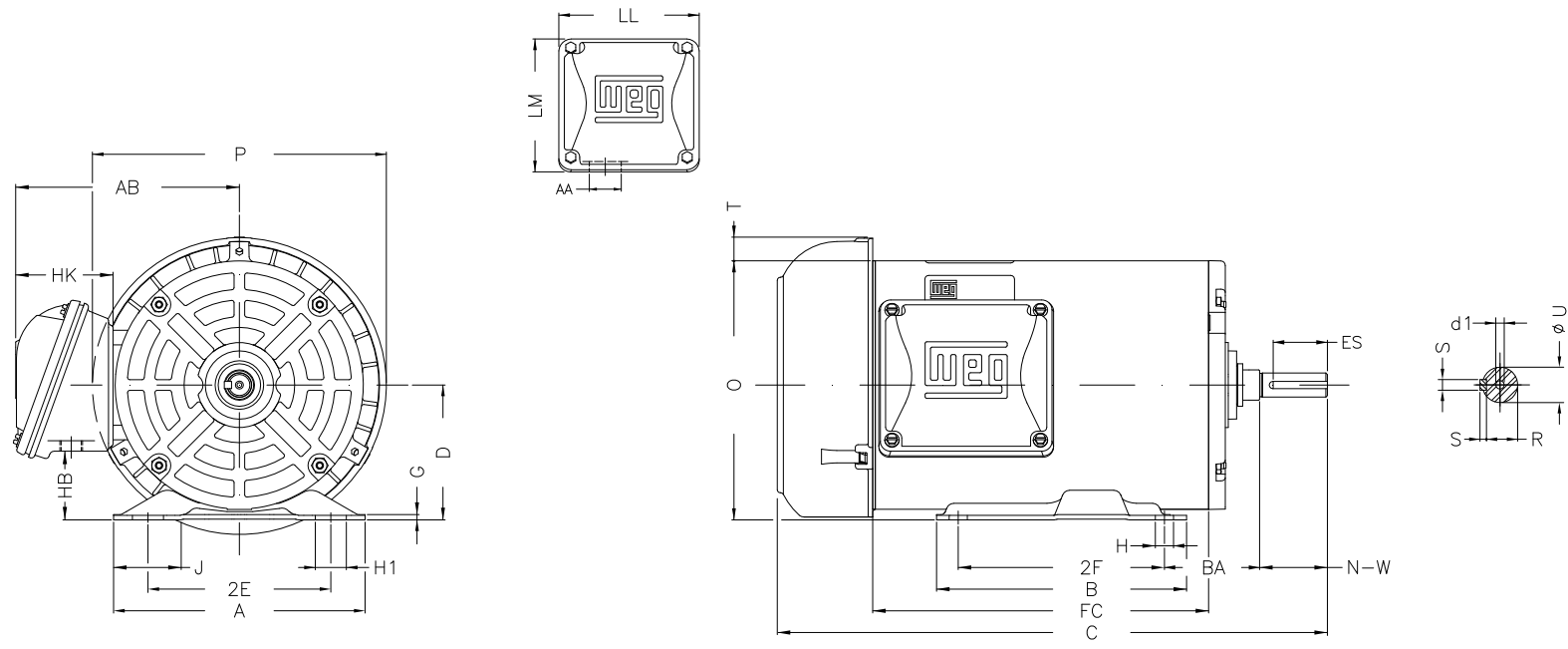

Notes: Downloaded from <http://dealerselectric.com>  
Generated for Model #00118ES3E56-S

Performed by:

Checked:

Customer:

Three Phase: W01 (Rolled Steel) - TEFC - Standard Efficiency

P	AB	J	2E	A
7.638	5.882	1.732	4.874	6.535
H	G	HB	HK	T
0.343	0.120	1.783	2.638	0.603
O	FC	2F	B	C
6.724	6.693	3.000	4.016	12.323
BA	N-W	ES	d1	S
2.750	1.874	1.417	A 3,15	0.187
U	AA	depth	R	LL
0.625	0.881"	0.187	0.517	4.543
LM	BB	D		
4.106	0.603	3.500		

Three-phase induction motor  
Frame 56 - IP55

12-SEP-2016

