



Dealers Industrial Equipment

No.:

Date: 12-SEP-2016

Customer :

TECHNICAL PROPOSAL

Three-phase induction motor - Squirrel cage rotor

Product line : Three Phase: W01 (Rolled Steel) - TEFC - Standard Efficiency

Catalog Number : 00112ES3H56CFL-S

List Price : \$454

Notes:

Downloaded from <http://dealerselectric.com>

Generated for Model #00112ES3H56CFL-S

Performed by:

Checked:



Dealers Industrial Equipment

No.:

Date: 12-SEP-2016

DATA SHEET Three-phase induction motor - Squirrel cage rotor

Customer :
 Product line : Three Phase: W01 (Rolled Steel) - TEFC - Standard Efficiency

Frame : 56H
 Output : 1 HP
 Frequency : 60 Hz
 Poles : 6
 Full load speed : 1145 rpm
 Slip : 4.58 %
 Voltage : 575 V
 Rated current : 1.34 A
 Locked rotor current : 7.48 A
 Locked rotor current (I_L/I_n) : 5.6
 No-load current : 0.920 A
 Full load torque : 4.52 lb.ft
 Locked rotor torque : 210 %
 Breakdown torque : 260 %
 Design : A
 Insulation class : F
 Temperature rise : 80 K
 Locked rotor time : 15 s (hot)
 Service factor : 1.15
 Duty cycle : S1
 Ambient temperature : -20°C - +40°C
 Altitude : 1000 m
 Degree of Protection : IP55
 Approximate weight : 34 lb
 Moment of inertia : 0.15970 sq.ft.lb
 Noise level : 50 dB(A)

	D.E.	N.D.E.
Bearings	6204 ZZ	6202 ZZ
Regreasing interval	---	---
Grease amount	---	---

Load	Power factor	Efficiency (%)
100%	0.73	77.0
75%	0.63	75.5
50%	0.50	72.0

Notes:
 Downloaded from <http://dealerselectric.com>
 Generated for Model #00112ES3H56CFL-S

Performed by

Checked



Dealers Industrial Equipment

No.:

Date: 12-SEP-2016

PERFORMANCE CURVES RELATED TO RATED OUTPUT

Three-phase induction motor - Squirrel cage rotor

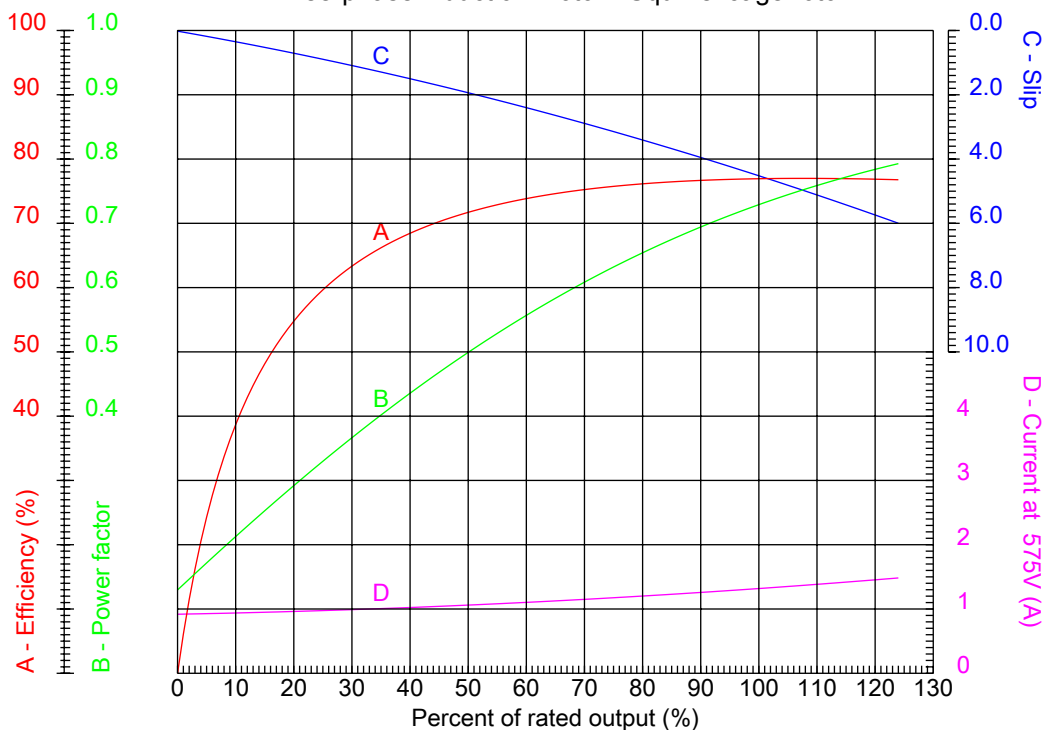

Customer :
 Product line : Three Phase: W01 (Rolled Steel) - TEFC - Standard Efficiency

Frame : 56H	Locked rotor current (I _L /I _n) : 5.6
Output : 1 HP	Duty cycle : S1
Frequency : 60 Hz	Service factor : 1.15
Full load speed : 1145 rpm	Design : A
Voltage : 575 V	Locked rotor torque : 210 %
Rated current : 1.34 A	Breakdown torque : 260 %
Insulation class : F	

Notes:
 Downloaded from <http://dealerselectric.com>
 Generated for Model #00112ES3H56CFL-S

Performed by

Checked



Dealers Industrial Equipment

No.:

Date: 12-SEP-2016

CHARACTERISTIC CURVES RELATED TO SPEED

Three-phase induction motor - Squirrel cage rotor

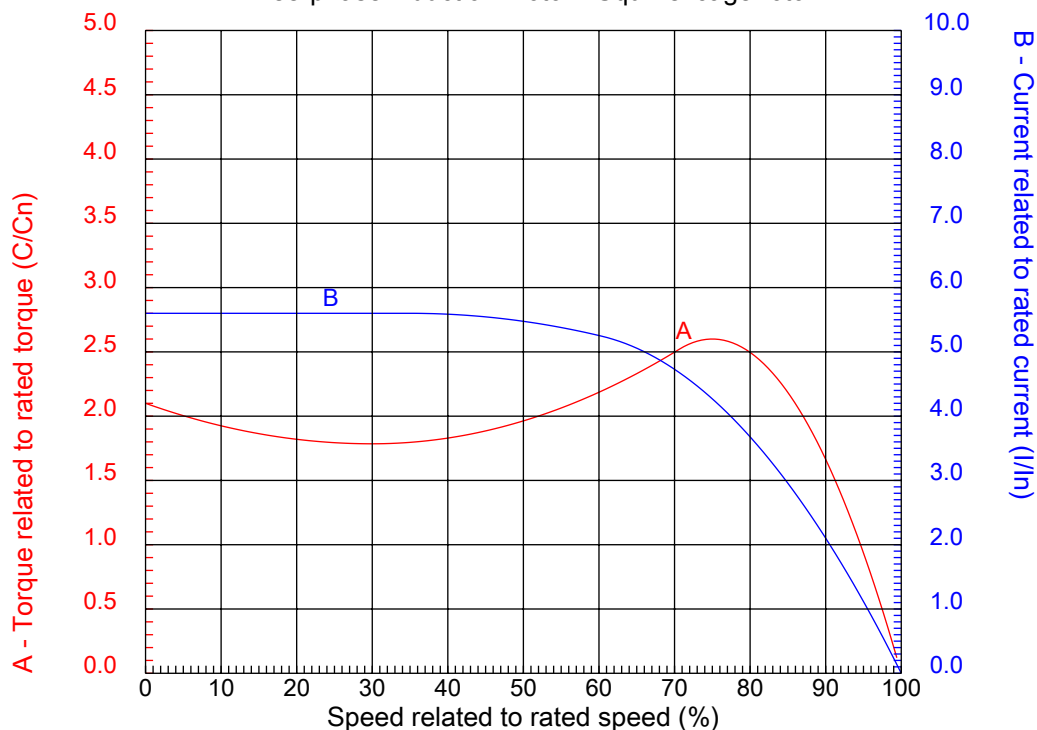

Customer :
Product line : Three Phase: W01 (Rolled Steel) - TEFC - Standard Efficiency

Frame	: 56H	Locked rotor current (I _l /I _h)	: 5.6
Output	: 1 HP	Duty cycle	: S1
Frequency	: 60 Hz	Service factor	: 1.15
Full load speed	: 1145 rpm	Design	: A
Voltage	: 575 V	Locked rotor torque	: 210 %
Rated current	: 1.34 A	Breakdown torque	: 260 %
Insulation class	: F		

Notes:
Downloaded from <http://dealerselectric.com>
Generated for Model #00112ES3H56CFL-S

Performed by

Checked

1 2 3 4 5 6 7 8

A

B

C

D

E

F

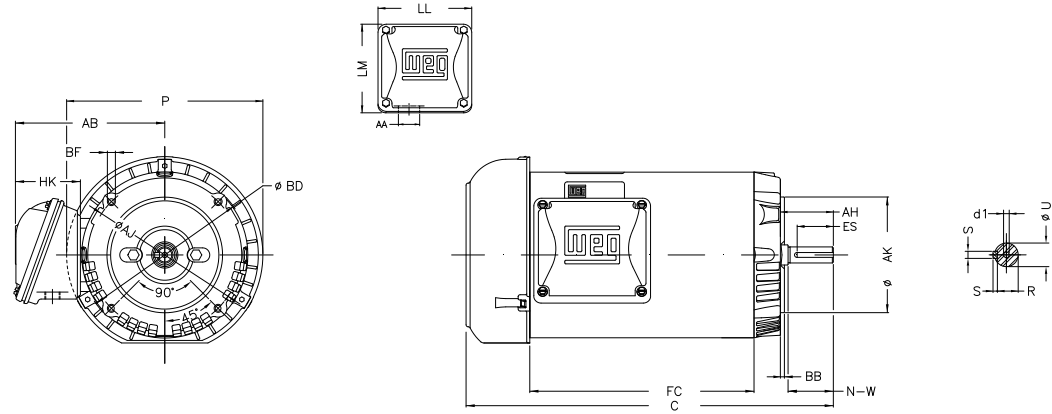

Notes: Downloaded from <http://dealerselectric.com>
Generated for Model #00112ES3H56CFL-S

Performed by:

Checked:

Customer:

Three Phase: W01 (Rolled Steel) - TEFC - Standard Efficiency

P	AB	HK	FC	C
7.638	5.882	2.638	7.874	13.504
N-W	ES	d1	S	U
1.874	1.417	A 3.15	0.187	0.625
AA	depth	R	LL	LM
0.881"	0.187	0.517	4.543	4.106
Flange	AJ	AK	BD	BF
FC-149	5.874	4.500	6.450	UNC 3/8"x16-2B
BB	AH			
0.157	2.062			

Three-phase induction motor
Frame 56H - IP55

12-SEP-2016

