



Dealers Industrial Equipment

No.:

Date: 12-SEP-2016

Customer :

TECHNICAL PROPOSAL

Three-phase induction motor - Squirrel cage rotor

Product line : Three Phase: W01 (Rolled Steel) - TEFC - Standard Efficiency

Catalog Number : .5012ES3H56CFL-S

List Price : \$441

Notes:

Downloaded from <http://dealerselectric.com>

Generated for Model #.5012ES3H56CFL-S

Performed by:

Checked:



Dealers Industrial Equipment

No.:

Date: 12-SEP-2016

DATA SHEET Three-phase induction motor - Squirrel cage rotor

Customer :
 Product line : Three Phase: W01 (Rolled Steel) - TEFC - Standard Efficiency

Frame : 56
 Output : 0.5 HP
 Frequency : 60 Hz
 Poles : 6
 Full load speed : 1160 rpm
 Slip : 3.33 %
 Voltage : 575 V
 Rated current : 0.794 A
 Locked rotor current : 4.29 A
 Locked rotor current (I_L/I_n) : 5.4
 No-load current : 0.618 A
 Full load torque : 2.23 lb.ft
 Locked rotor torque : 210 %
 Breakdown torque : 300 %
 Design : A
 Insulation class : F
 Temperature rise : 80 K
 Locked rotor time : 22 s (hot)
 Service factor : 1.15
 Duty cycle : S1
 Ambient temperature : -20°C - +40°C
 Altitude : 1000 m
 Degree of Protection : IP55
 Approximate weight : 25 lb
 Moment of inertia : 0.10655 sq.ft.lb
 Noise level : 50 dB(A)

	D.E.	N.D.E.
Bearings	6203 ZZ	6202 ZZ
Regreasing interval	---	---
Grease amount	---	---

Load	Power factor	Efficiency (%)
100%	0.65	72.0
75%	0.56	70.0
50%	0.44	64.0

Notes:
 Downloaded from <http://dealerselectric.com>
 Generated for Model #.5012ES3H56CFL-S

Performed by

Checked



Dealers Industrial Equipment

No.:

Date: 12-SEP-2016

PERFORMANCE CURVES RELATED TO RATED OUTPUT Three-phase induction motor - Squirrel cage rotor

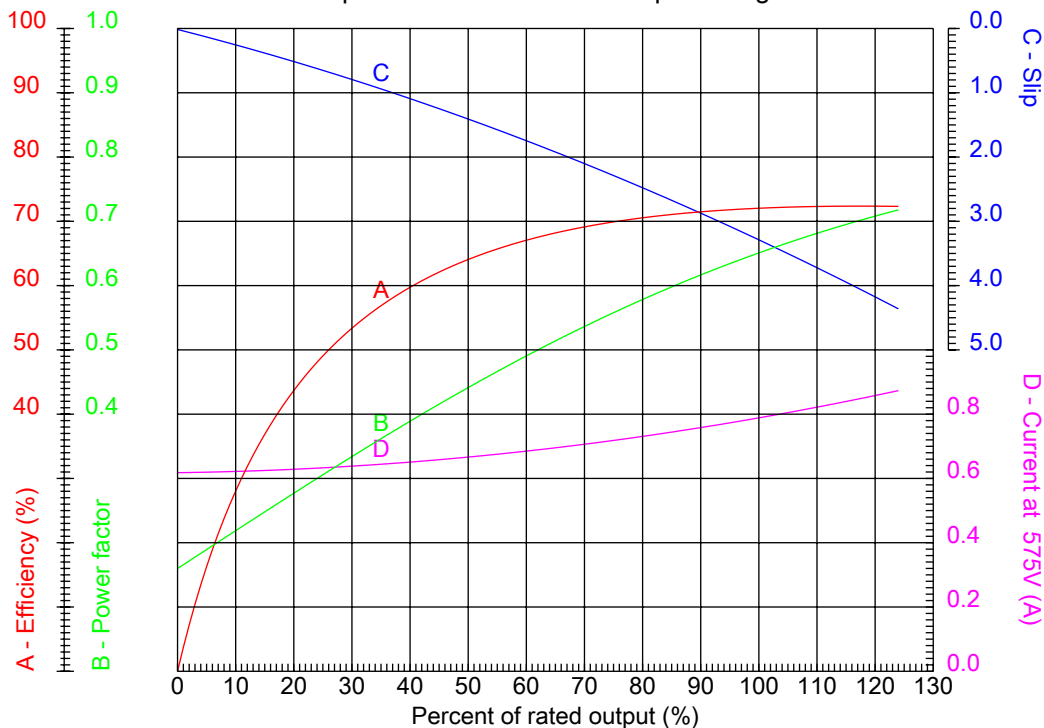

Customer :
 Product line : Three Phase: W01 (Rolled Steel) - TEFC - Standard Efficiency

Frame : 56	Locked rotor current (I _L /I _n) : 5.4
Output : 0.5 HP	Duty cycle : S1
Frequency : 60 Hz	Service factor : 1.15
Full load speed : 1160 rpm	Design : A
Voltage : 575 V	Locked rotor torque : 210 %
Rated current : 0.794 A	Breakdown torque : 300 %
Insulation class : F	

Notes:
 Downloaded from <http://dealerselectric.com>
 Generated for Model #.5012ES3H56CFL-S

Performed by

Checked



Dealers Industrial Equipment

No.:

Date: 12-SEP-2016

CHARACTERISTIC CURVES RELATED TO SPEED

Three-phase induction motor - Squirrel cage rotor

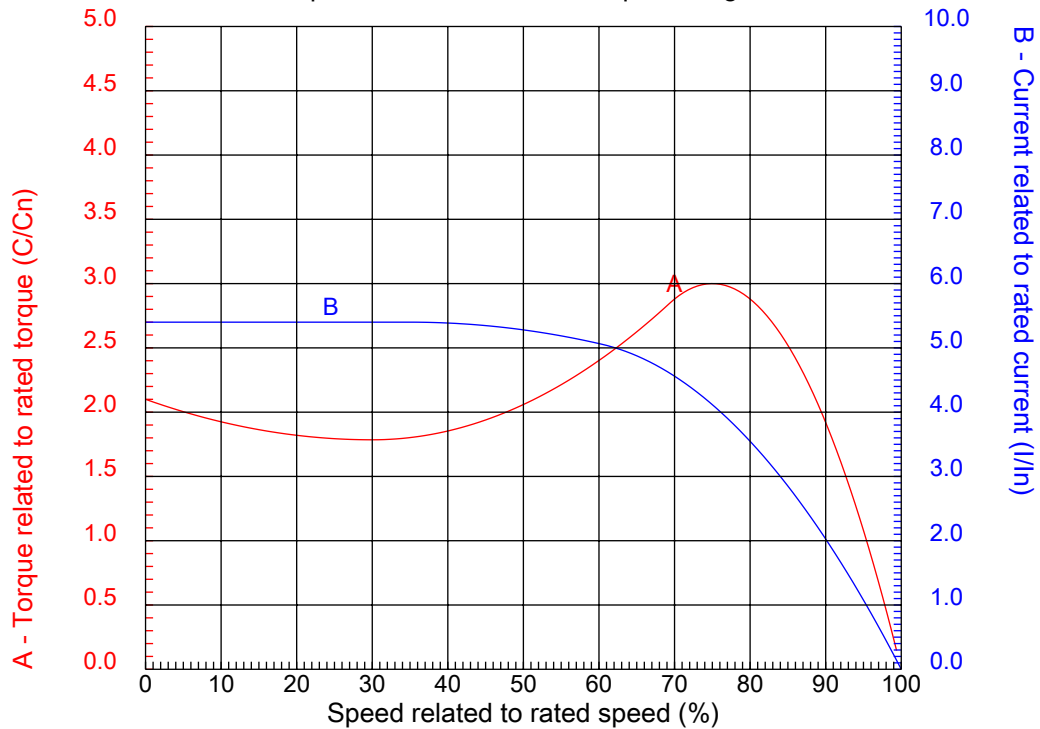

Customer :
Product line : Three Phase: W01 (Rolled Steel) - TEFC - Standard Efficiency

Frame	: 56	Locked rotor current (I _l /I _n)	: 5.4
Output	: 0.5 HP	Duty cycle	: S1
Frequency	: 60 Hz	Service factor	: 1.15
Full load speed	: 1160 rpm	Design	: A
Voltage	: 575 V	Locked rotor torque	: 210 %
Rated current	: 0.794 A	Breakdown torque	: 300 %
Insulation class	: F		

Notes:
Downloaded from <http://dealerselectric.com>
Generated for Model #.5012ES3H56CFL-S

Performed by

Checked

1 2 3 4 5 6 7 8

A

B

C

D

E

F

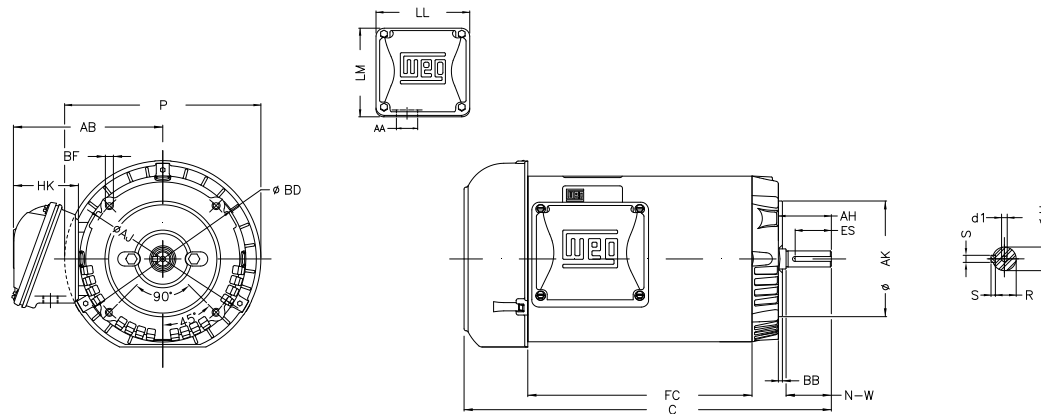

Notes: Downloaded from <http://dealerselectric.com>
Generated for Model #.5012ES3H56CFL-S

Performed by:

Checked:

Customer:

Three Phase: W01 (Rolled Steel) - TEFC - Standard Efficiency

Three-phase induction motor
Frame 56 - IP55

12-SEP-2016



P	AB	HK	FC	C
7.638	5.882	2.638	6.693	12.323
N-W	ES	d1	S	U
1.874	1.417	A 3.15	0.187	0.625
AA	depth	R	LL	LM
0.881"	0.187	0.517	4.543	4.106
Flange	AJ	AK	BD	BF
FC-149	5.874	4.500	6.450	UNC 3/8"x16-2B
BB	AH			
0.157	2.062			