



Dealers Industrial Equipment

No.:

Date: 12-SEP-2016

Customer :

TECHNICAL PROPOSAL

Three-phase induction motor - Squirrel cage rotor

Product line : Three-Phase: Fractional Explosion Proof Motors

Catalog Number : .3318XS3E56

List Price : \$713

Notes:

Downloaded from <http://dealerselectric.com>

Generated for Model #.3318XS3E56

Performed by:

Checked:



Dealers Industrial Equipment

No.:

Date: 12-SEP-2016

DATA SHEET

Three-phase induction motor - Squirrel cage rotor

Customer :
 Product line : Three-Phase: Fractional Explosion Proof Motors

Frame : 56
 Output : 0.33 HP
 Frequency : 60 Hz
 Poles : 4
 Full load speed : 1725 rpm
 Slip : 4.17 %
 Voltage : 208-230/460 V
 Rated current : 1.30-1.18/0.588 A
 Locked rotor current : 7.88/3.94 A
 Locked rotor current (I_L/I_n) : 6.7
 No-load current : 1.00/0.500 A
 Full load torque : 0.991 lb.ft
 Locked rotor torque : 310 %
 Breakdown torque : 430 %
 Design : A
 Insulation class : F
 Temperature rise : 80 K
 Locked rotor time : 8 s (hot)
 Service factor : 1.00
 Duty cycle : S1
 Ambient temperature : -20°C - +50°C
 Altitude : 1000 m
 Degree of Protection : IP55
 Approximate weight : 21 lb
 Moment of inertia : 0.01400 sq.ft.lb
 Noise level : ---

	D.E.	N.D.E.
Bearings	6203 ZZ	6203 ZZ
Regreasing interval	---	---
Grease amount	---	---

Load	Power factor	Efficiency (%)
100%	0.69	77.3
75%	0.60	74.0
50%	0.48	67.0

Notes:
 Downloaded from <http://dealerselectric.com>
 Generated for Model #.3318XS3E56

Performed by

Checked



Dealers Industrial Equipment

No.:

Date: 12-SEP-2016

PERFORMANCE CURVES RELATED TO RATED OUTPUT

Three-phase induction motor - Squirrel cage rotor

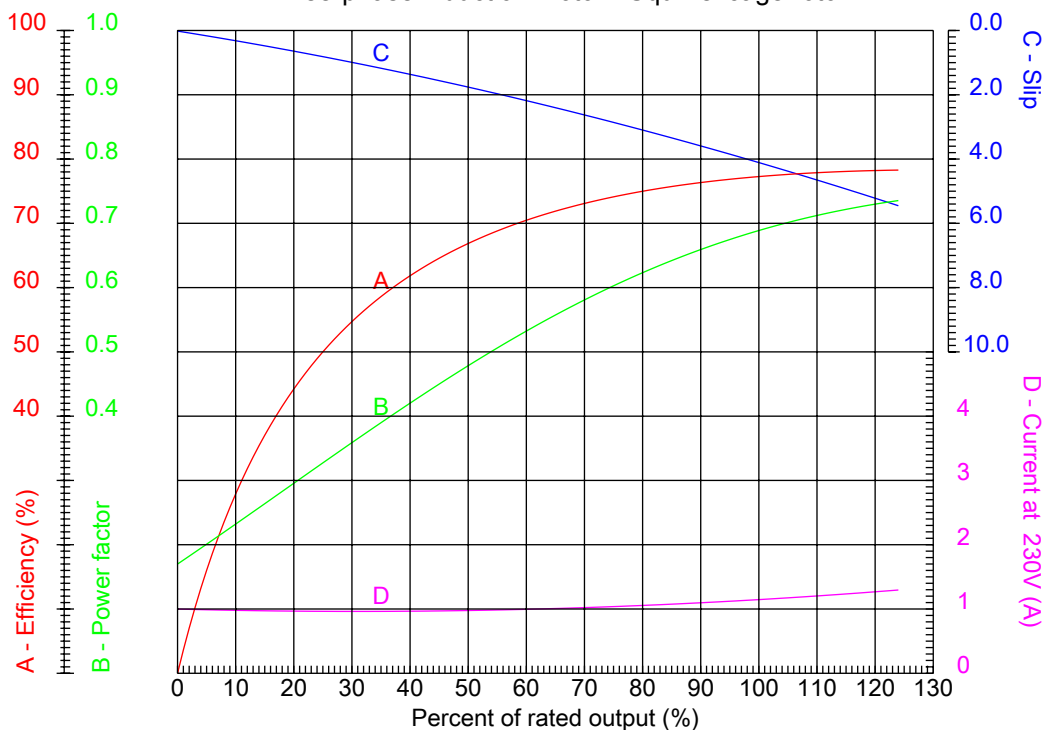

Customer :
 Product line : Three-Phase: Fractional Explosion Proof Motors

Frame	: 56	Locked rotor current (I _l /I _n)	: 6.7
Output	: 0.33 HP	Duty cycle	: S1
Frequency	: 60 Hz	Service factor	: 1.00
Full load speed	: 1725 rpm	Design	: A
Voltage	: 208-230/460 V	Locked rotor torque	: 310 %
Rated current	: 1.30-1.18/0.588 A	Breakdown torque	: 430 %
Insulation class	: F		

Notes:
 Downloaded from <http://dealerselectric.com>
 Generated for Model #.3318XS3E56

Performed by

Checked



CHARACTERISTIC CURVES RELATED TO SPEED

Three-phase induction motor - Squirrel cage rotor

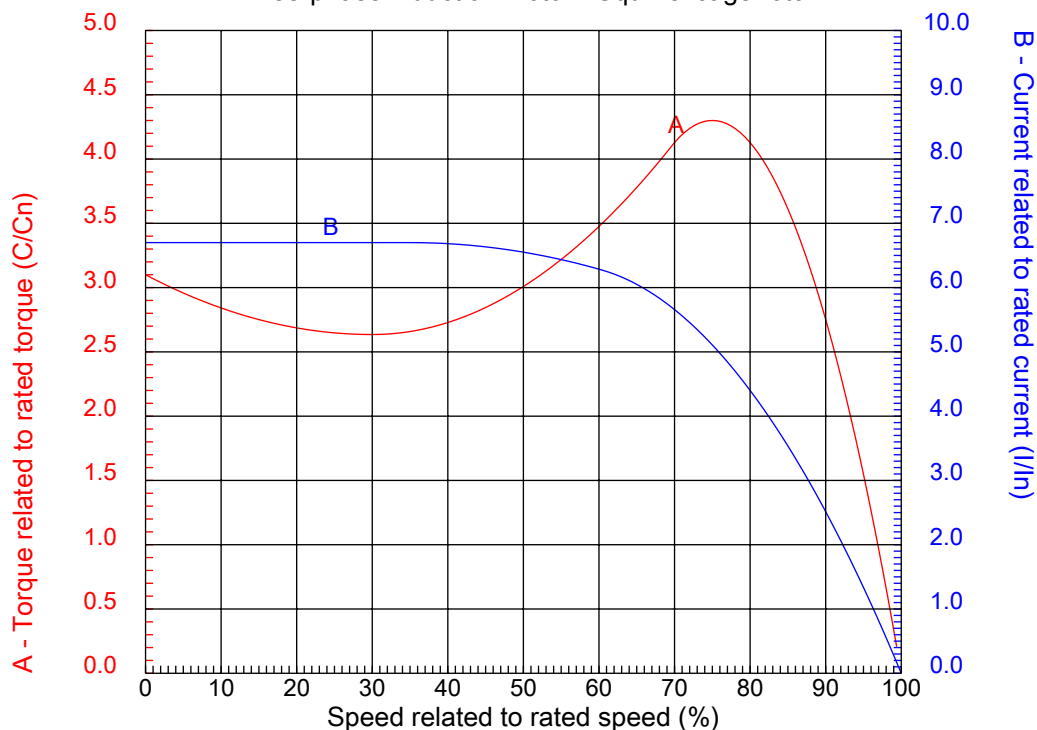

Customer :
Product line : Three-Phase: Fractional Explosion Proof Motors

Frame	: 56	Locked rotor current (I _l /I _n)	: 6.7
Output	: 0.33 HP	Duty cycle	: S1
Frequency	: 60 Hz	Service factor	: 1.00
Full load speed	: 1725 rpm	Design	: A
Voltage	: 208-230/460 V	Locked rotor torque	: 310 %
Rated current	: 1.30-1.18/0.588 A	Breakdown torque	: 430 %
Insulation class	: F		

Notes:
Downloaded from <http://dealerselectric.com>
Generated for Model #.3318XS3E56

Performed by

Checked

1 2 3 4 5 6 7 8

A

B

C

D

E

F

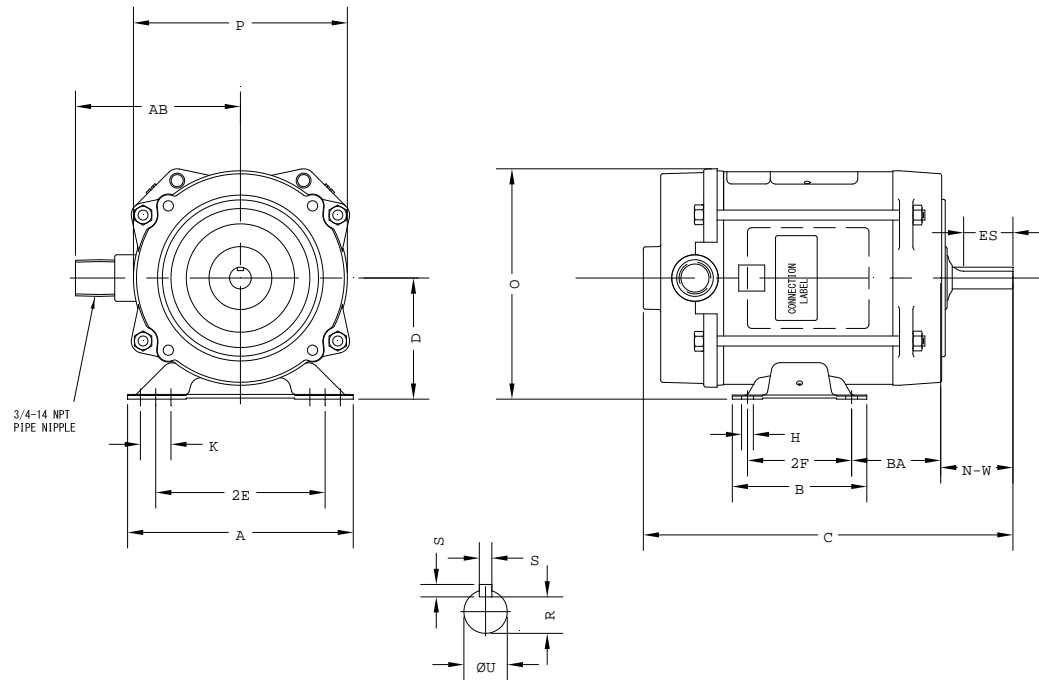

Notes: Downloaded from <http://dealerselectric.com>
Generated for Model #.3318XS3E56

Performed by:

Checked:

Customer:

Three-Phase: Fractional Explosion Proof Motors

Three-phase induction motor
Frame 56 - IP55

12-SEP-2016



2E 4.880	A 6.500	P 6.980	B 3.880	BA 2.750
U 0.6250	N-W 1.880	ES 1.380	S 0.190	R 0.517
D 3.500	O 6.920	H 0.340	C 10.520	d1 SEM