

DRAWING NUMBER

REF: A3NEW

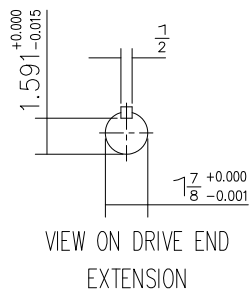
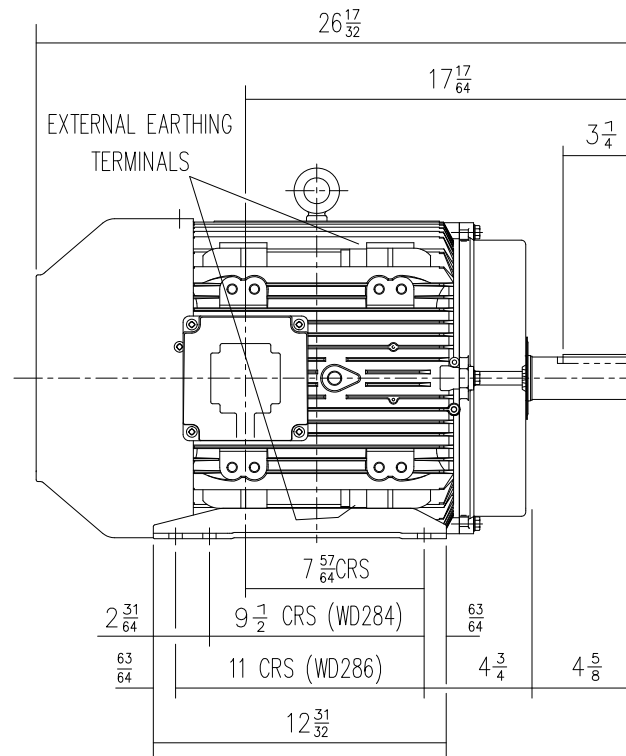
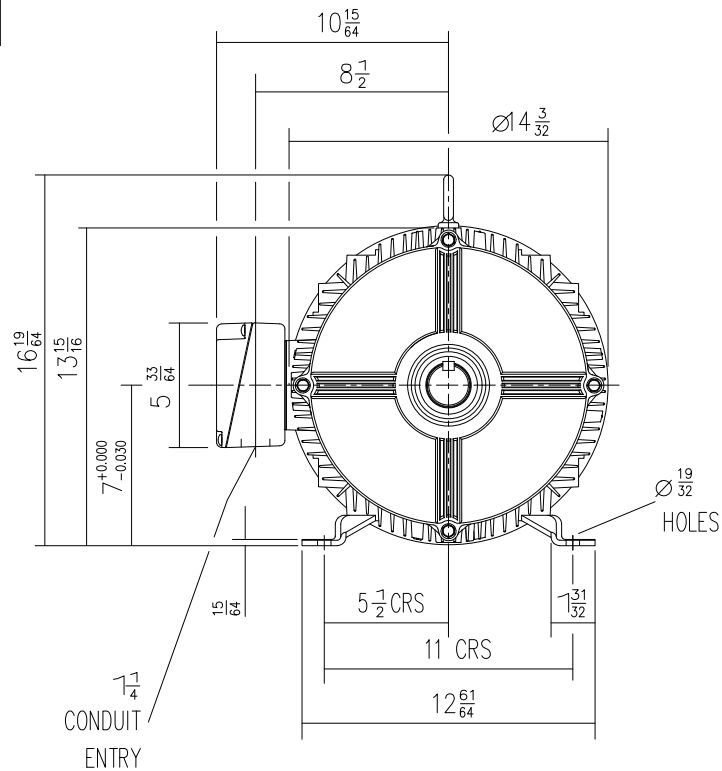

TERMINAL BOX POSITION:- CAN BE ARRANGED AT EITHER 9, 12, OR 3 O'CLOCK BY MOVING FEET.

DRAIN HOLES:- WHEN TERMINAL BOX IS MOVED FROM STANDARD POSITION THEY WILL NEED TO BE PLUGGED AND RE-LOCATED ELSEWHERE - IF REQUIRED. STANDARD TERMINAL BOX POSITION IS 9 O'CLOCK AS SHOWN.

CONDUIT ENTRIES:- TERMINAL BOX CAN BE ROTATED AT 90° INTERVALS. (CONDUIT ENTRY POSITION SHOWN FOR ILLUSTRATION ONLY).

CUSTOMER		
ORDER No.		
SERIAL No.		
FRAME SIZE		
KW.	RPM.	
Hz	PHASE	
VOLTS	POLES	
BRGS.	DE.	NDE.
MOTOR NETT WT.		Kg.
SPECIAL REMARKS		

ALL DIMENSIONS IN INCHES

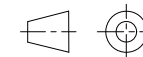

FIRST ANGLE PROJECTION

# BROOK CROMPTON

SHEET SIZE A3	TITLE	OUTLINE DIMENSION DRAWING W ALUMINIUM TOTALLY ENCLOSED FAN COOLED 284/6T FRAME FOOT MOUNTED MOTOR.	NAME	DATE
	DRAWN			
	CHECKED			
	SCALE	1 : 6		

DRG. No.	
REVISION:	DATE