

DATE
Jan. 14, 2011
CAT. #: VHP0204

OUTLINE DIMENSIONS
3-PHASE INDUCTION MOTOR

MOTOR TYPE:
AMRCNH
FRAME NO. 256TP

Pole	HP	kW	Hz	VOLT	Syn.Speed r/min(rpm)
4	20	15	60	230/460	1800

Ins	Rating	Dimension in	Approx Weight	Bearings
F	CONT.	inch	339 lbs	DE: 6309ZZC3 NDE: 7311B

NEMA Weather Protected TYPE I (WP I) Squirrel-cage Rotor.

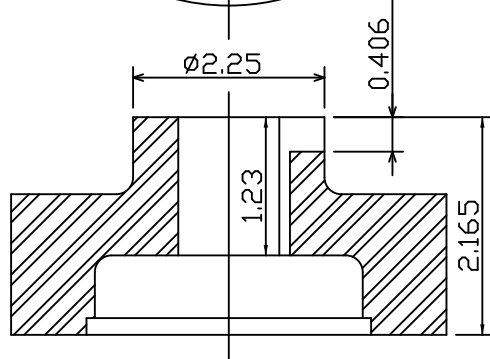
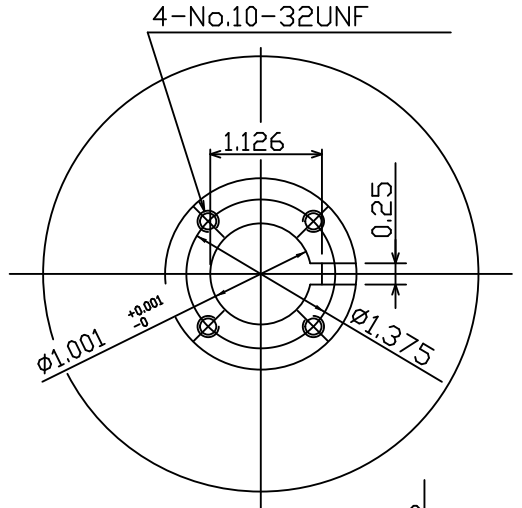
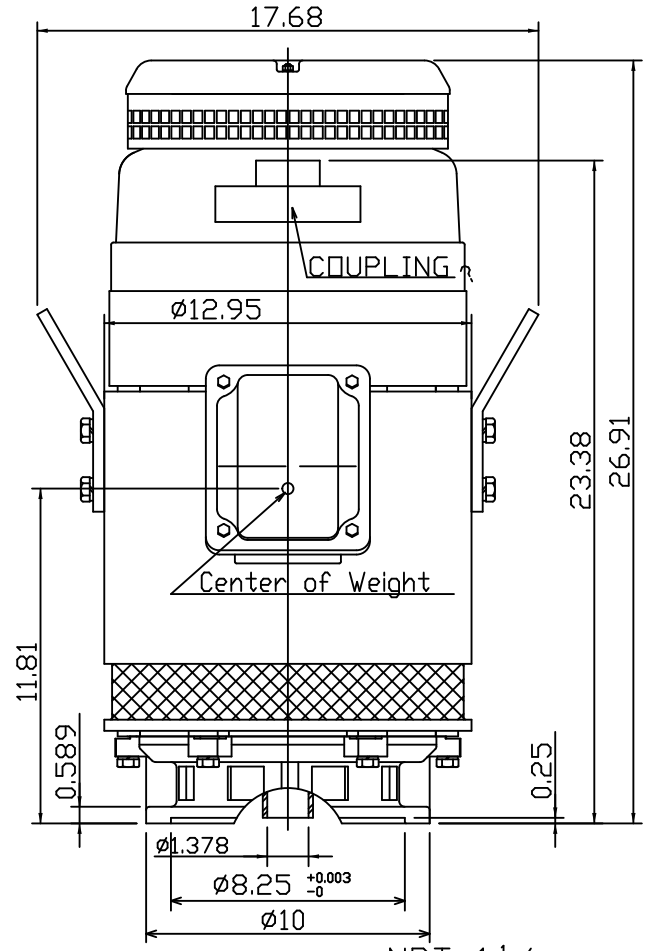

Coupling Dimension

- Note:
1. Downthrust: 3350lbs
L10 - 8800 hours
 2. Rotation: C.C.W
Viewed from Top
 3. With N.R.R.
 4. Approx Reed
Frequencies: 83 Hz

12.27.08

DWN.	????????	12 15 08
CHKD.	???????	01 09 09
APPD.	????????	01 09 09



DWG NO.
31057H807091