

DATE
Jan. 14, 2012
CAT. #: VHP0104

OUTLINE DIMENSIONS
3-PHASE INDUCTION MOTOR

MOTOR TYPE:
AMRCNH
FRAME NO. 215TP

Pole	HP	kW	Hz	VOLT	Syn.Speed r/min(rpm)
4	10	7.5	60	230/460	1800

Ins	Rating	Dimension in	Approx Weight	Bearings
F	CONT.	inches	216 lbs	DE: 6209ZZC3 NDE: 7310BE

NEMA Weather Protected TYPE I (WP I) Squirrel-cage Rotor.

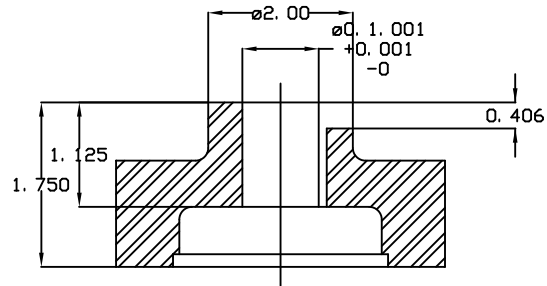
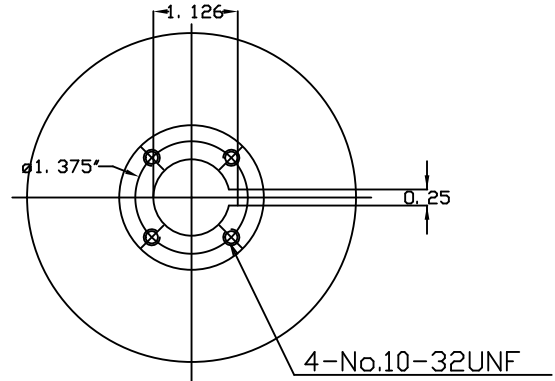
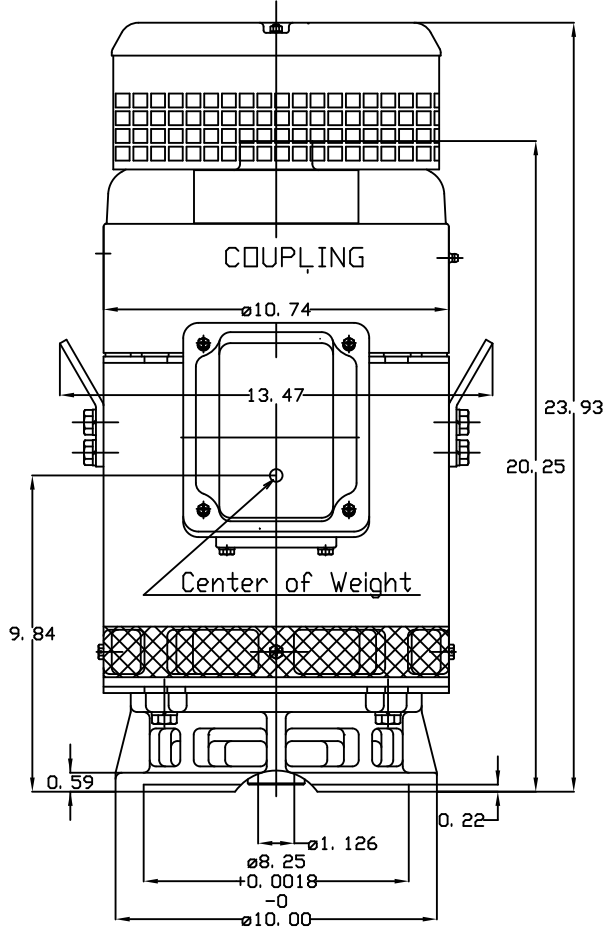

Coupling Dimension

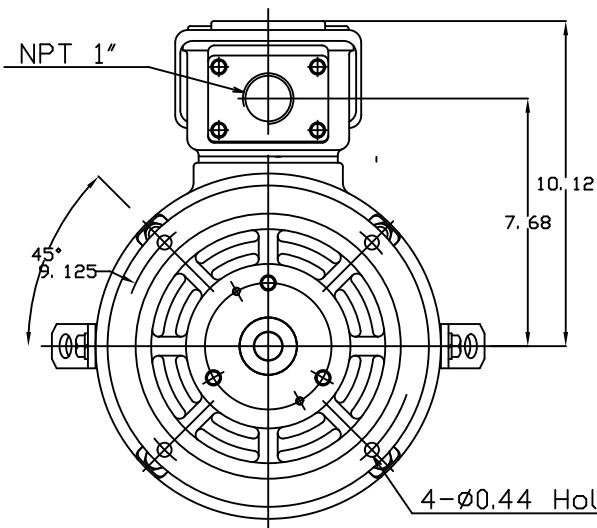

- Note:
1. Downthrust :2600lbs
L10 - 8800 hours
 2. Rotation: C.C.W
View from Top
 3. With N.R.R.
 4. Approx Reed
Frequencies: 110 Hz

12.27.08

DWN.	????????	12 14 08
CHKD.	???????	01 09 09
APPD.	????????	01 09 09



DWG NO.
31049R179101