

DATE March 8, 2004	OUTLINE DIMENSIONS 3-PHASE INDUCTION MOTOR	MOTOR TYPE: ASFAFP
CATALOG NO. Q0606		FRAME NO. 404T

Pole	HP	kW	Hz	VOLT	Syn. Speed r/min(rpm)
6	60	45	60	230/460/796	1200

Ins	Rating	Dimension in	Approx Weight	Bearings	
F	CONT.	inches	1144 lbs.	DE: 6317	NDE: 6317

Open Protected Drip-Proof Type. Squirrel-cage Rotor.

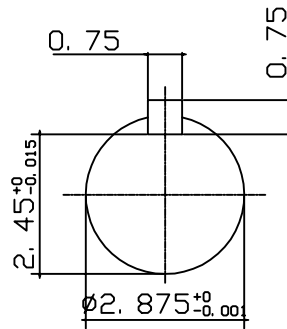
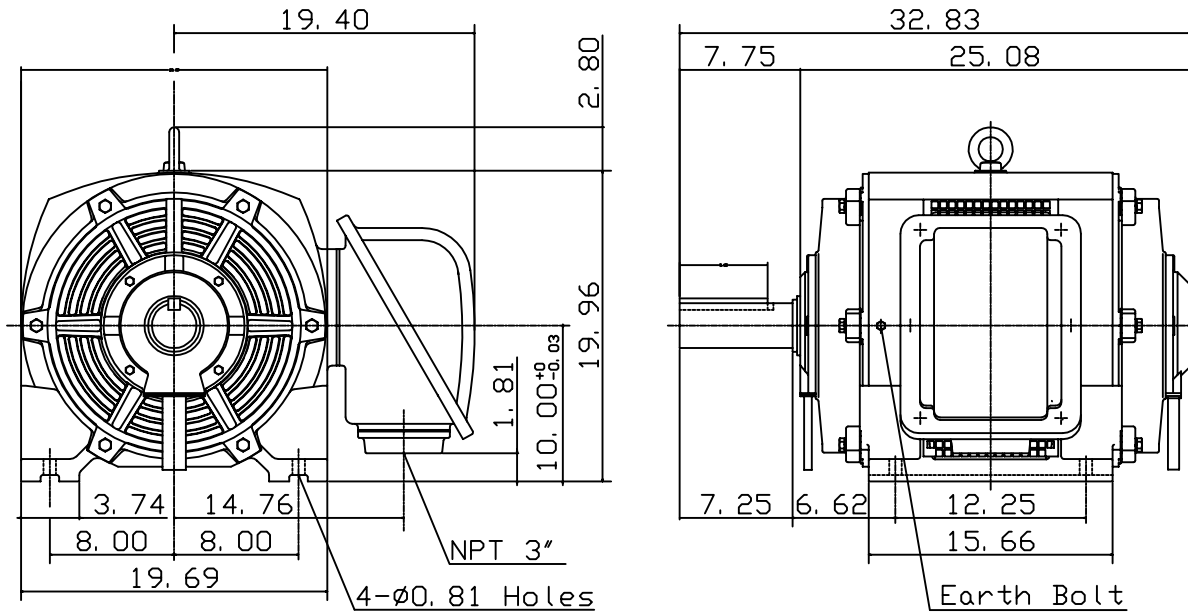

0		
---	--	--

DWN.	J. H. LIANG	12 · 22 · 98
CHKD.	C. H. KAO	06 · 10 · 99
APPD.	Y. B. HUANG	06 · 10 · 99

TECO Westinghouse

DWG NO.
31049U534011