

TYPE	OUTPUT		POLE	TIME RATING	VOLTAGE	Hz	SYN. SPEED R.P.M
	HP.	KW.					
ASHA-PA	1000	746	6	CONT.	2300/4160	60	1200

WEATHER PROTECTED TYPE I. SQUIRREL-CAGE ROTOR

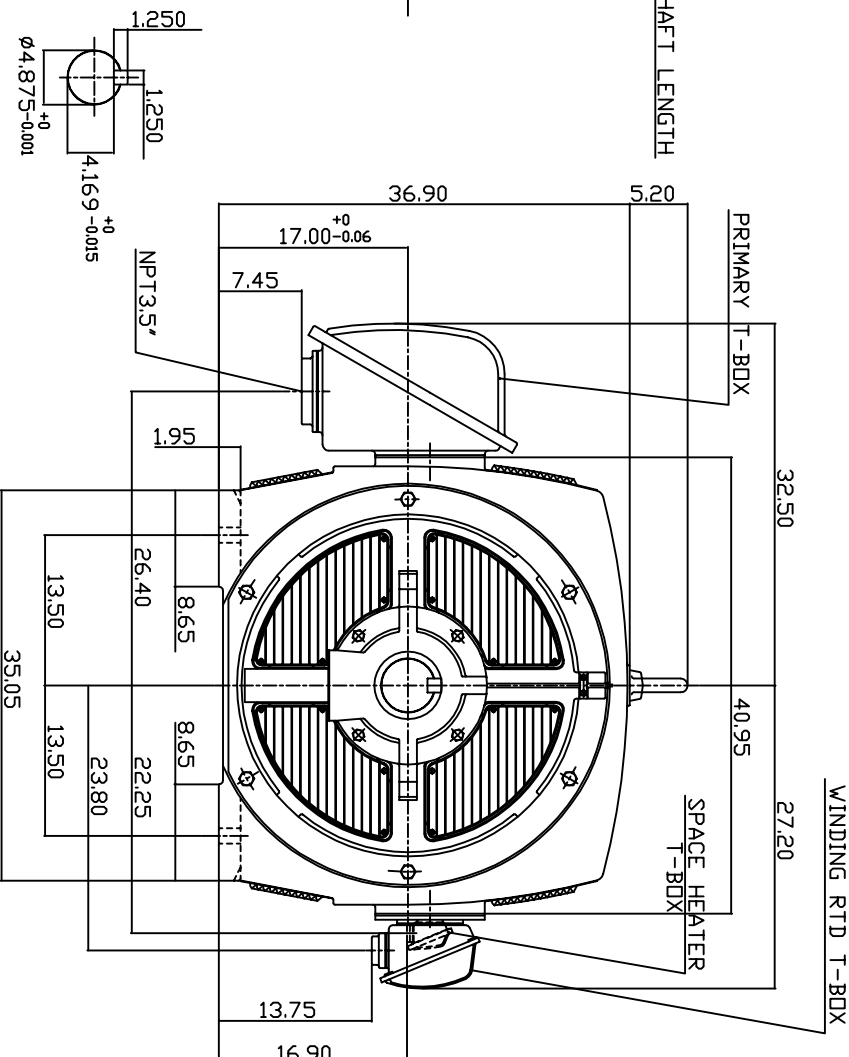
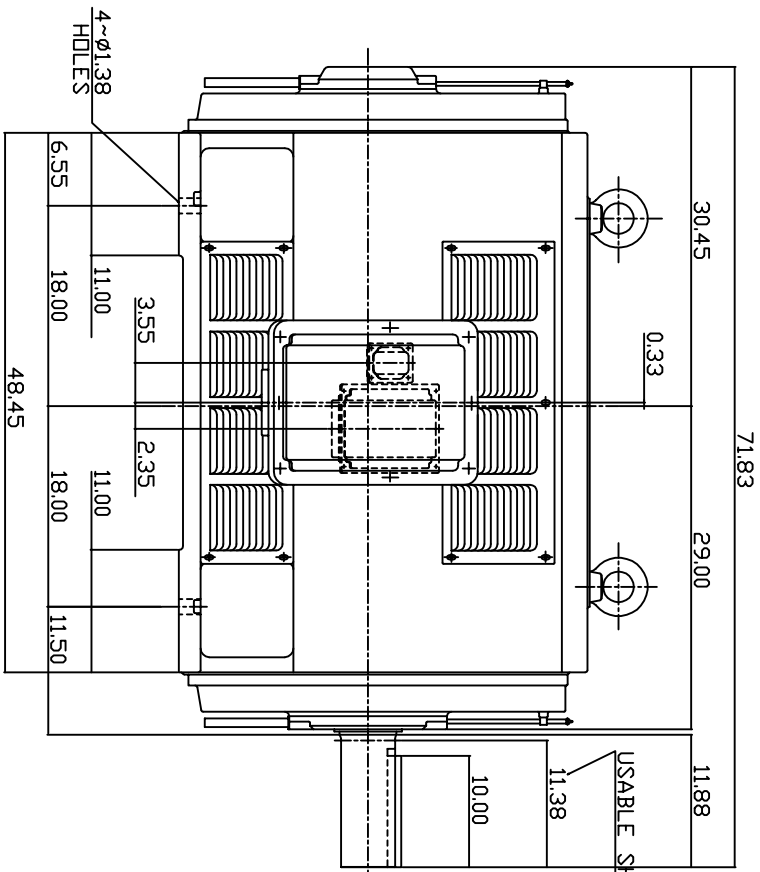

NOTE: 1. DIMENSIONS IN INCH.

2. FRAME NO. 6808C
3. F CLASS INSULATION, SF.115
4. FOR BELT DRIVE APPLICATIONS
5. WITH SPACE HEATER 120 VOLT SINGLE PHASE 300 WATTS
6. 100 DHM PLATINUM WINDING RTD'S 2/PHASE
7. BEARING SIZE: DRIVE END: NU326
NON-DRIVE END: 6322
8. MOTOR APPROX. WEIGHT: 8200 LBS

TW-66C

DVN.	W.LLIN	APR-17-2003
CHKD.	W.LLIN	APR-17-2003
APPD.	C.WANG	APR-17-2003

DATE	MAY 6, 2004	OUTLINE DIMENSIONS
CATALOG NO.	P10006R	3-PHASE INDUCTION MOTOR
TECO Westinghouse		DWG NO. 3A040T3905
REV: 00		