

TYPE	OUTPUT		POLE	TIME RATING	VOLTAGE V	HZ	SYN SPEED R.P.M
	HP.	KW.					
ASHA-PA	1000	746	4	CDNT.	2300/4160	60	1800

WEATHER PROTECTED TYPE I. SQUIRREL-CAGE ROTOR

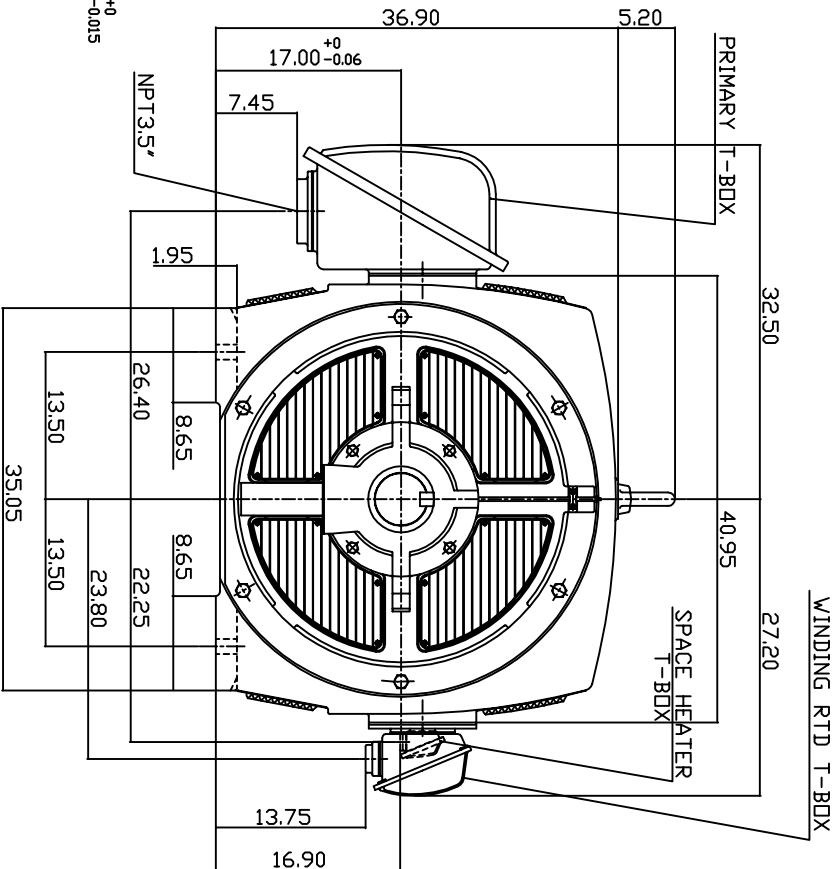
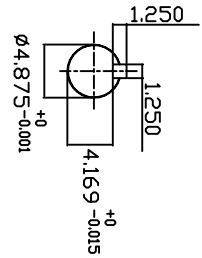
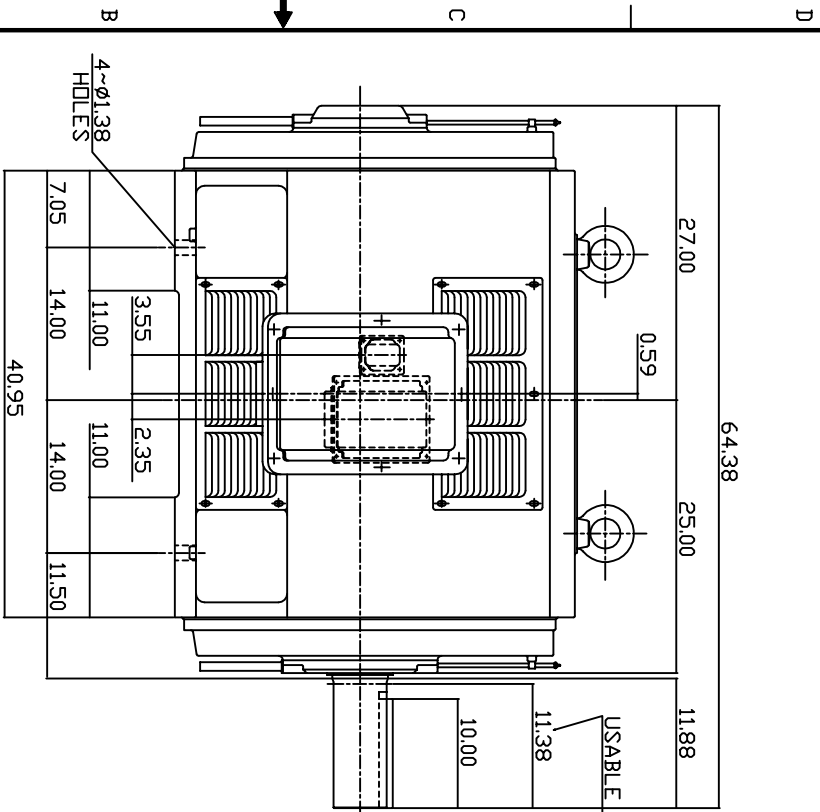

NOTE: 1. DIMENSIONS IN INCH.

2. FRAME NO. 6806B
3. F CLASS INSULATION, S.F.115
4. FOR DIRECT FLEXIBLE COUPLING
5. WITH SPACE HEATER 120 VOLT SINGLE PHASE 300 WATTS
6. 100 OHM PLATINUM WINDING RTD'S 2/PHASE
7. BEARING SIZE: DRIVE END: 6326
NON-DRIVE END: 6322
8. MOTOR APPROX. WEIGHT: 6200 LBS

TV-66C

DWN.	V.LLIN	APR-17-2003
CHKD.	V.LLIN	APR-17-2003
APPD.	C.VANG	APR-17-2003

DATE	MAY 6, 2004	OUTLINE DIMENSIONS
CATALOG NO.	P10004	3-PHASE INDUCTION MOTOR



DWG NO. 3A040T3898 REV: 00