



OUTLINE DIMENSIONS

MOTOR TYPE:
AEUH8P-XXX

DATE

3-PHASE INDUCTION MOTOR

FRAME NO. 182TC

Pole	HP	kW	Hz	VOLT	r/min
4	3	2.238	60	230/460	1800
Ins	Rating	Dimension in	Approx Weight	Bearings	
F	CONT.	inches		DE: 6306ZZ NDE: 6306ZZ	

Totally Enclosed Fan-Cooled Vertical Type. Squirrel-Cage Rotor.

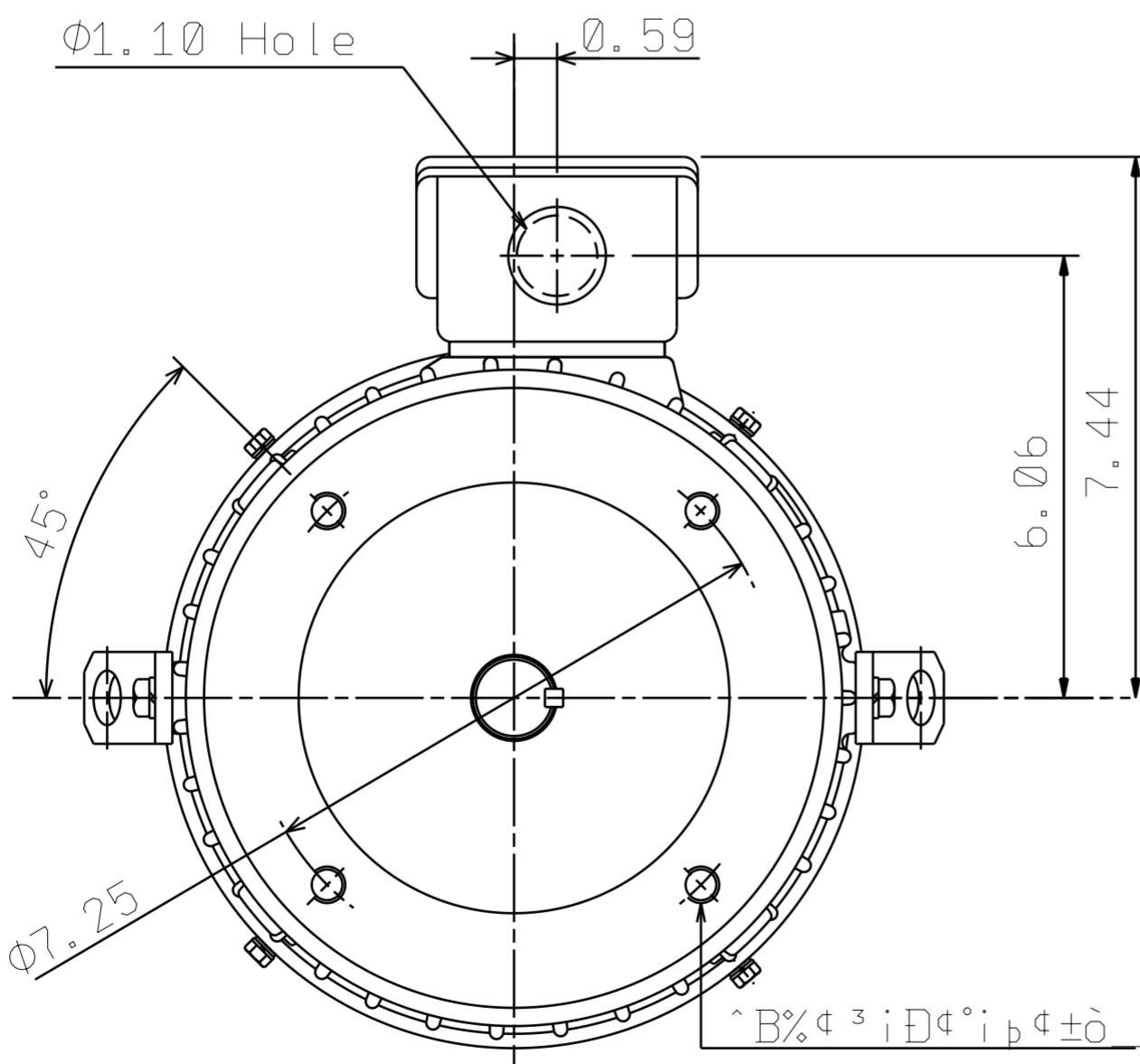
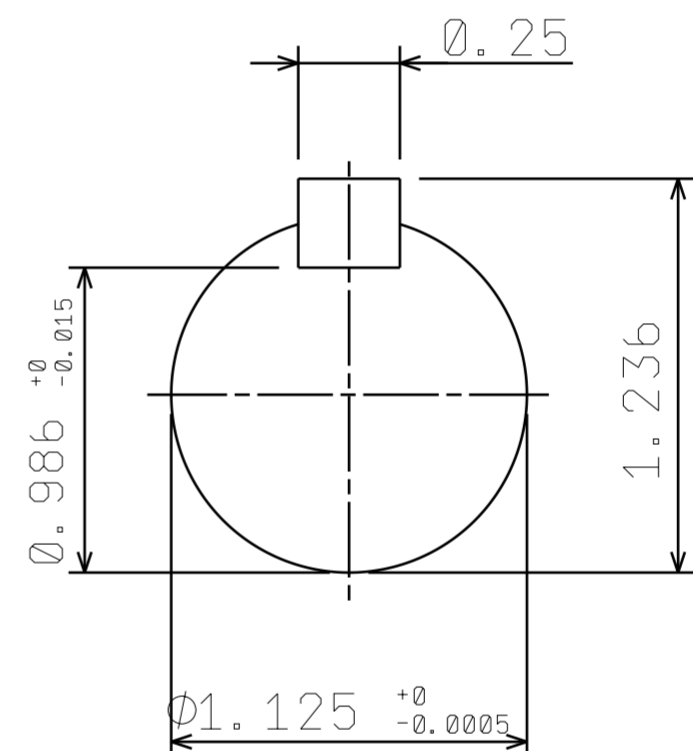
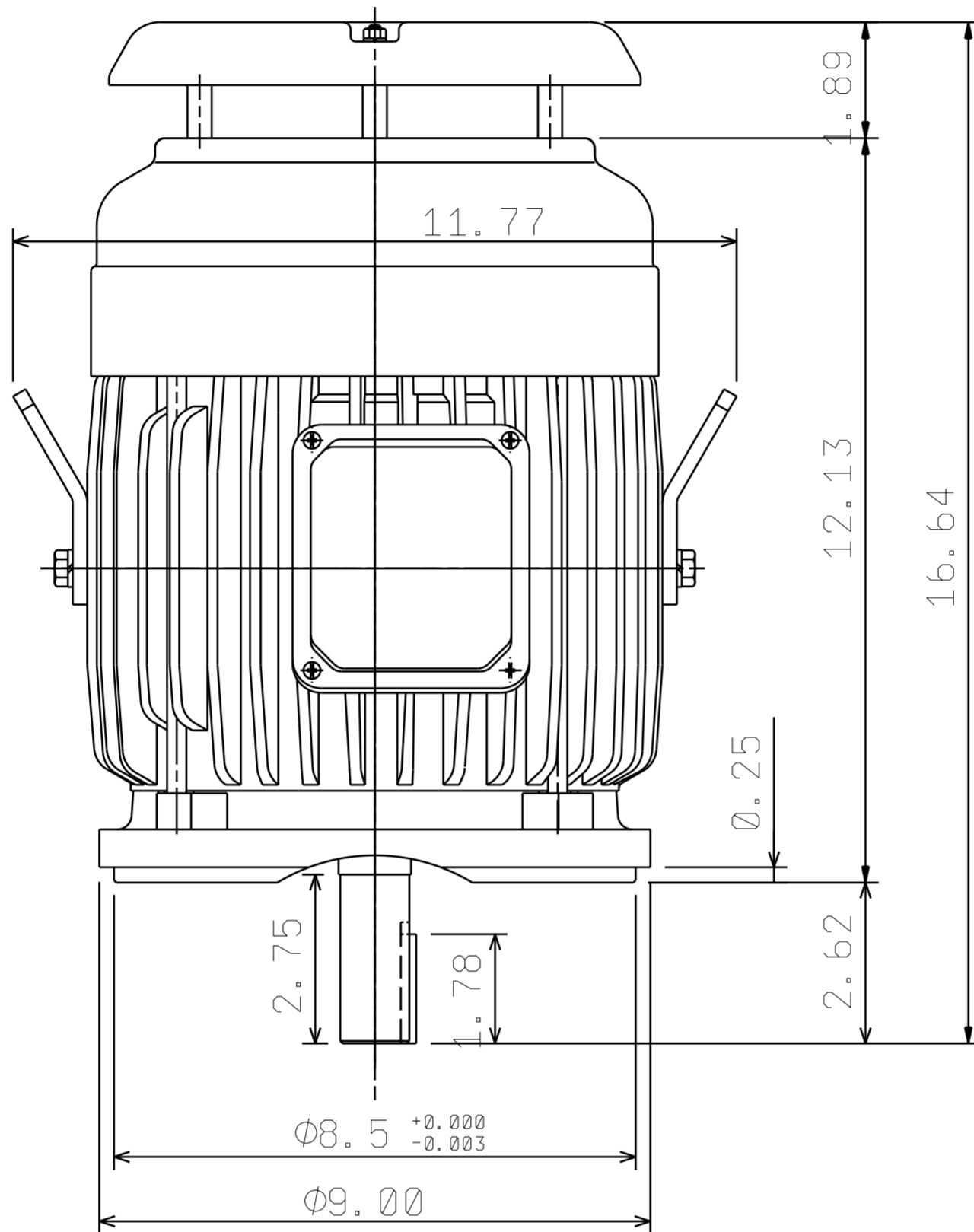

TAI17142-00-01



DWG.	^ B%\$0007AM
CHKD.	^ B%R041017
APPD.	^ B%R041017

東元電機股份有限公司
TECO Electric & Machinery Co., Ltd.
 TAIWAN

DWG NO.
 31057A209330