

TYPE	OUTPUT		POLE	TIME RATING	VOLTAGE V	Hz	SYN SPEED RPM
	HP.	KW.					
AEHH8P	200	149.2	6	CDNT.	460	60	1200

TOTALLY ENCLOSED FAN-COOLED TYPE, SQUIRREL-CAGE ROTOR

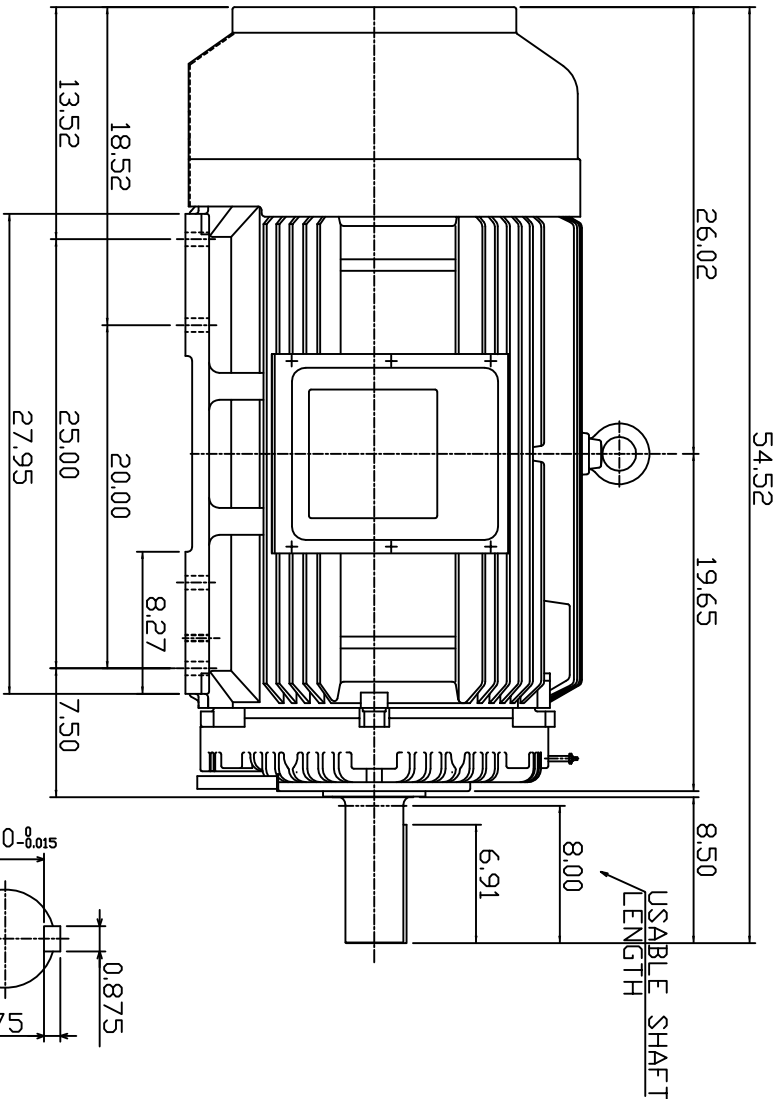
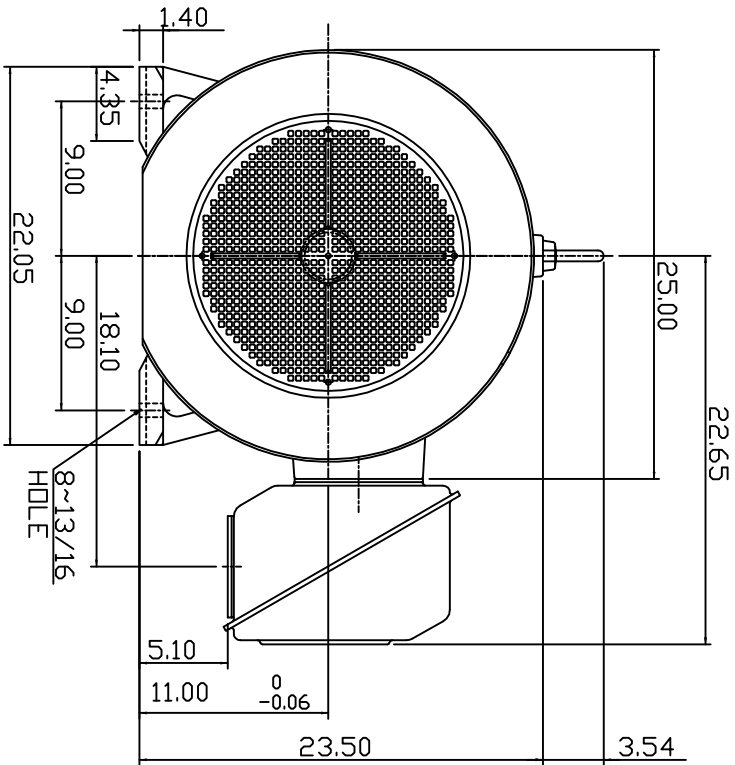

NOTE:

1. DIMENSIONS IN INCHES
2. FRAME SIZE 449T
3. F CLASS INSULATION, S.F. 1.15
4. FOR DIRECT FLEXIBLE COUPLING BEARING ND: DRIVE END: 6320C3 OPP. DRIVE END: 6316C3
5. ENCLDURE: IP44
6. APPRDX. WEIGHT: 2450 LBS
- 7.

DWN.	SLEE	JAN. 26 '2011
CHKD.	SLEE	JAN. 26 '2011
APPD.	H.LIU	JAN. 26 '2011

DATE: MARCH 2, 2011
 CATALOG #: NP2006

OUTLINE DIMENSIONS
 3-PHASE INDUCTION MOTOR



DWG. NO. 3A049DWB10464-28
 REV. 00

SHAFT END
 [ENLARGED VIEW]