

TYPE	OUTPUT		POLE	TIME RATING	VOLTAGE V	Hz	SYN SPEED R.P.M
	HP.	KW.					
AEH8P	200	149.2	2	CDNT.	380	50	3000

TOTALLY ENCLOSED FAN-COOLED TYPE, SQUIRREL-CAGE ROTOR

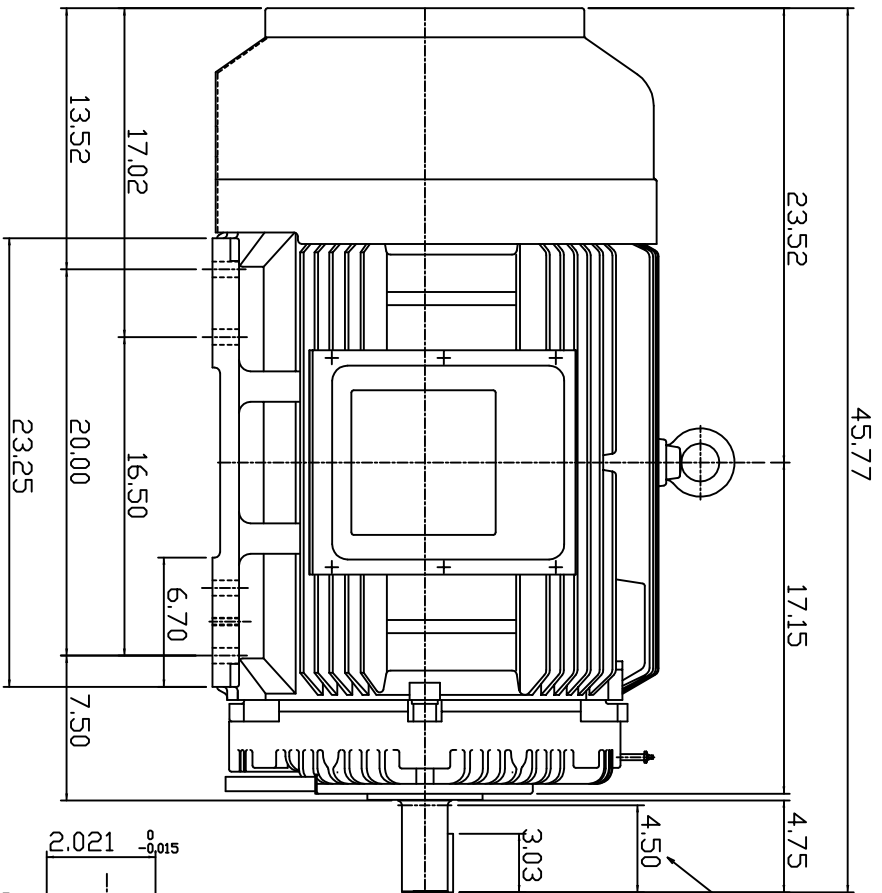
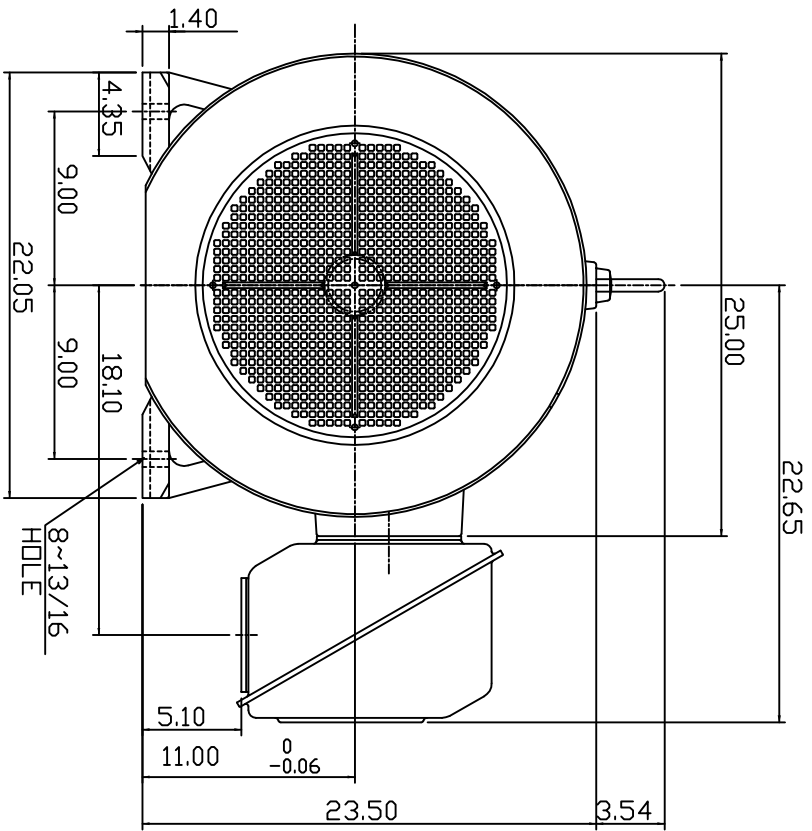

SHAFT END  
[ENLARGED VIEW]

USABLE SHAFT  
LENGTH

- NOTE:
1. DIMENSIONS IN INCHES
  2. FRAME SIZE 447TS
  3. F CLASS INSULATION, S.F. 1.0
  4. FOR DIRECT FLEXIBLE COUPLING
  5. BEARING NO.: DRIVE END: 6314C3  
OPP. DRIVE END: 6314C3
  6. ENCLOSURE: IP44
  7. APPRX. WEIGHT: 1900 LBS

DWN.	SLEE	JAN. 26 '2011
CHKD.	SLEE	JAN. 26 '2011
APPD.	H.LIU	JAN. 26 '2011

DATE	FEB. 11, 2011	DUTLINE DIMENSIONS
CATALOG #	NP2002	
3-PHASE INDUCTION MOTOR		



DWG NO. 3A049DWB10464-23  
REV: 00