

DATE  
JAN. 15, 2015

CAT. #: NP1/56G

# OUTLINE DIMENSIONS

## 3-PHASE INDUCTION MOTOR

MOTOR TYPE:  
AEHH8P-SGR

FRAME NO. 182T

Pole	HP	kW	Hz	VOLT	Syn.Speed r/min(rpm)
6	1.5	1.12	60	230/460	1200

Ins	Rating	Dimension in	Approx Weight	Bearings
F	CONT.	inch	81 lbs.	DE: 6306ZZ NDE: 6306ZZ

Totally Enclosed Fan Cooled Squirrel Cage Rotor.

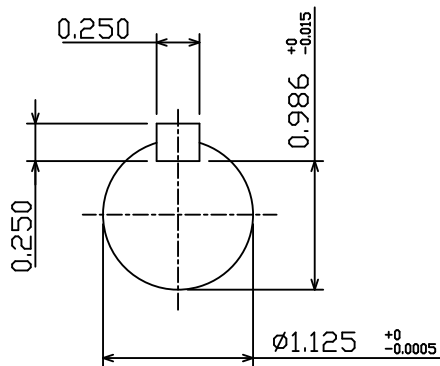
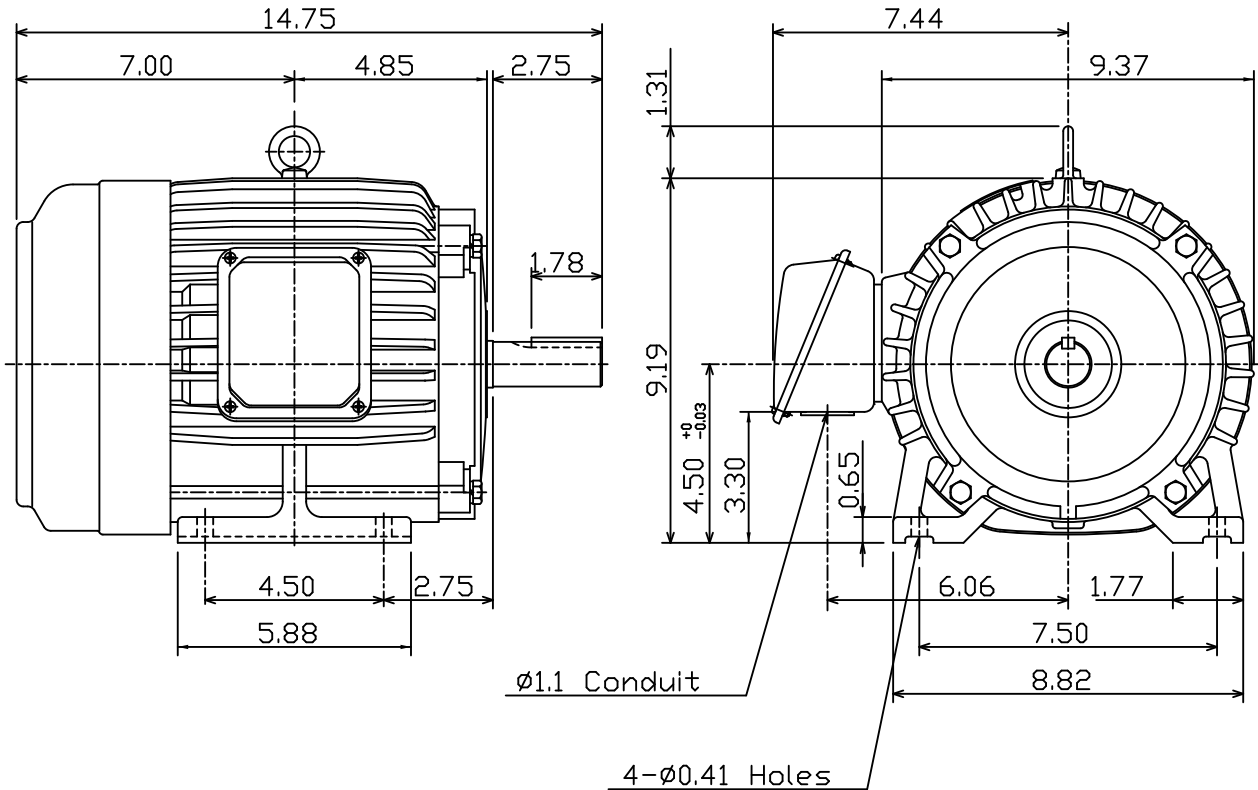

NOTE:  
1. Shaft Grounding Ring installed-NDE



DWN.	JH.LIANG	05-20-99
CHKD.	C.S.LO	05-26-99
APPD.	Y.B.HUANG	05-26-99

**TECO** **Westinghouse**

DWG NO.  
31049D189290