

TYPE	OUTPUT		POLE	TIME RATING	VOLTAGE V	Hz	SYN SPEED RPM
	HP.	KW.					
AEHH8P	125	93.3	6	CONT.	230/460	60	1200

TOTALLY ENCLOSED FAN-COOLED TYPE, SQUIRREL-CAGE ROTOR

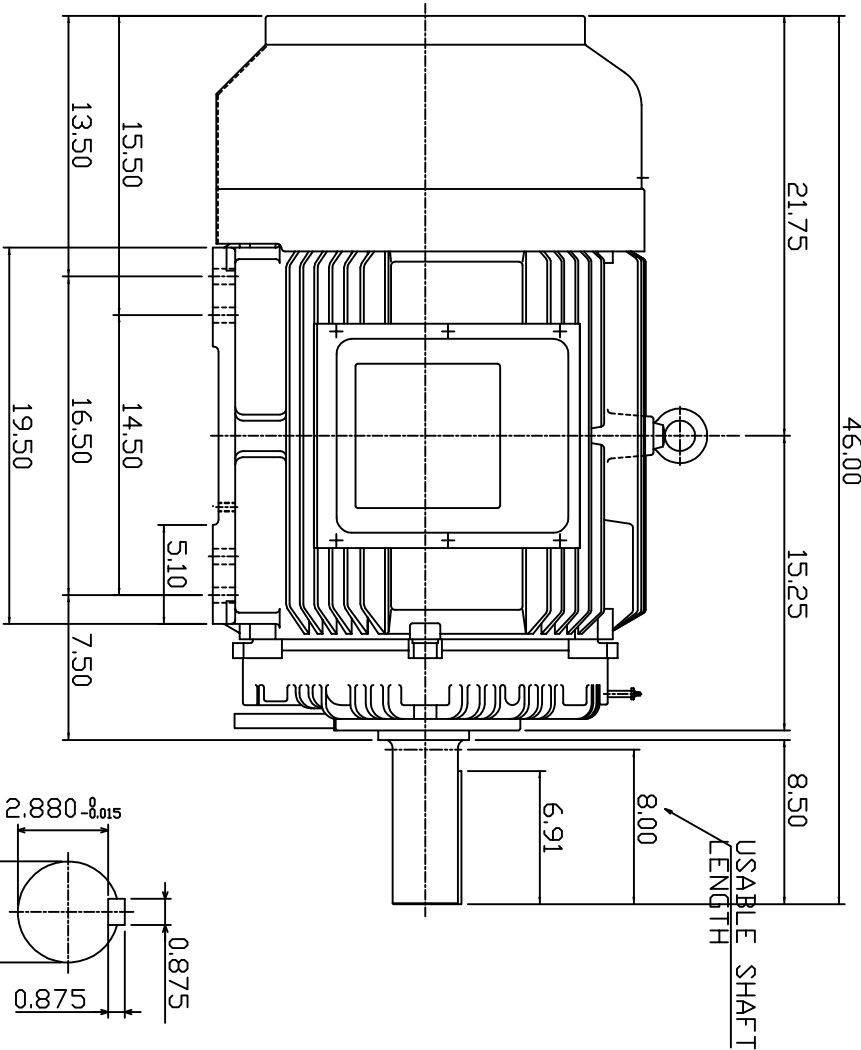
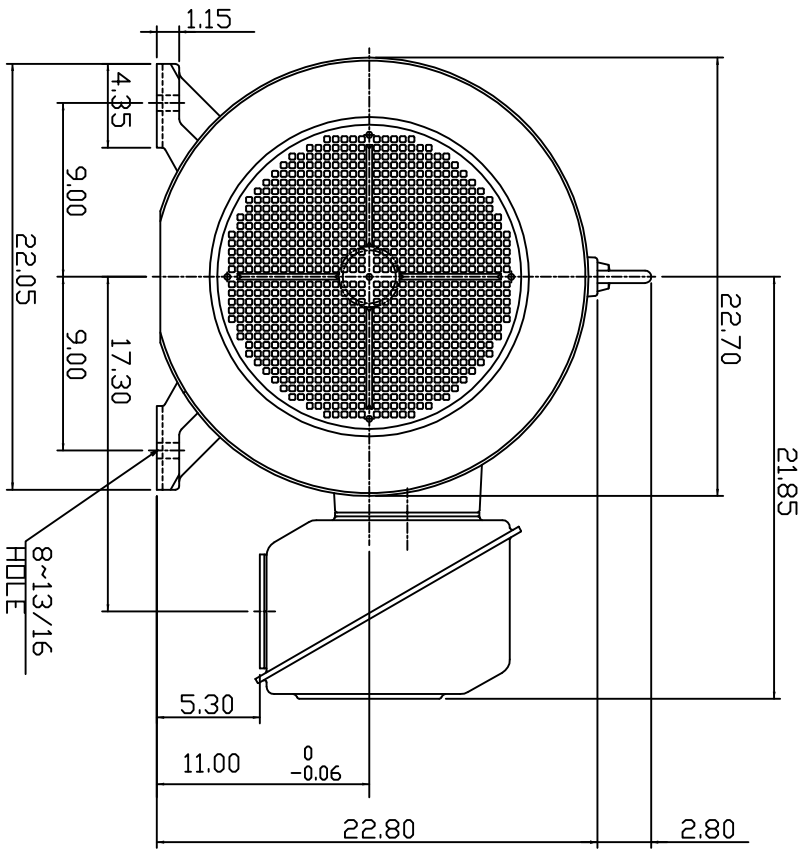

SHAFT END
ENLARGED VIEW

- NOTE:
1. DIMENSIONS IN INCHES
 2. FRAME SIZE 445T
 3. F CLASS INSULATION, S.F. 1.15
 4. FOR DIRECT FLEXIBLE COUPLING
 5. BEARING NO.: DRIVE END: 6318C3
DPP, DRIVE END: 6316C3
 6. ENCLOSURE: IP44
 7. APPRDX. WEIGHT: 1800 LBS

DWN.	SLEE	JAN. 26 -2011
CHKD.	SLEE	JAN. 26 -2011
APPD.	H.LIU	JAN. 26 -2011

DATE	FEB. 11, 2011	OUTLINE DIMENSIONS
CATALOG #	NP1256	
3-PHASE INDUCTION MOTOR		



DWG NO. 3A049DWB10464-26
REV. 00