

DATE
DEC. 16, 2010
CAT. #: NP1002

OUTLINE DIMENSIONS

3-PHASE INDUCTION MOTOR

MOTOR TYPE:
AEHH8P
FRAME NO. 405TS

Pole	HP	kW	Hz	VOLT	Syn.Speed r/min(rpm)
2	100	74.6	50	190/380	3000

Ins	Rating	Dimension in	Approx Weight	Bearings
F	CONT.	inch	1068 lbs.	DE: 6313C3 NDE: 6313C3

Totally Enclosed Fan Cooled Type.Squirrel-cage Rotor.

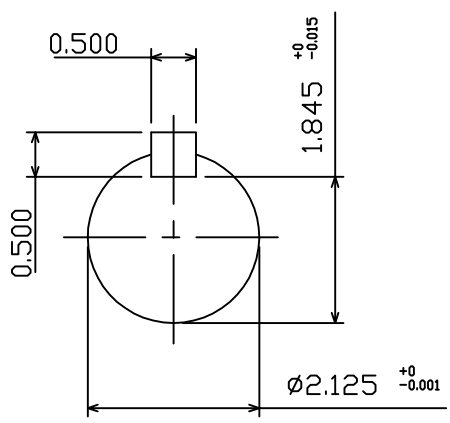
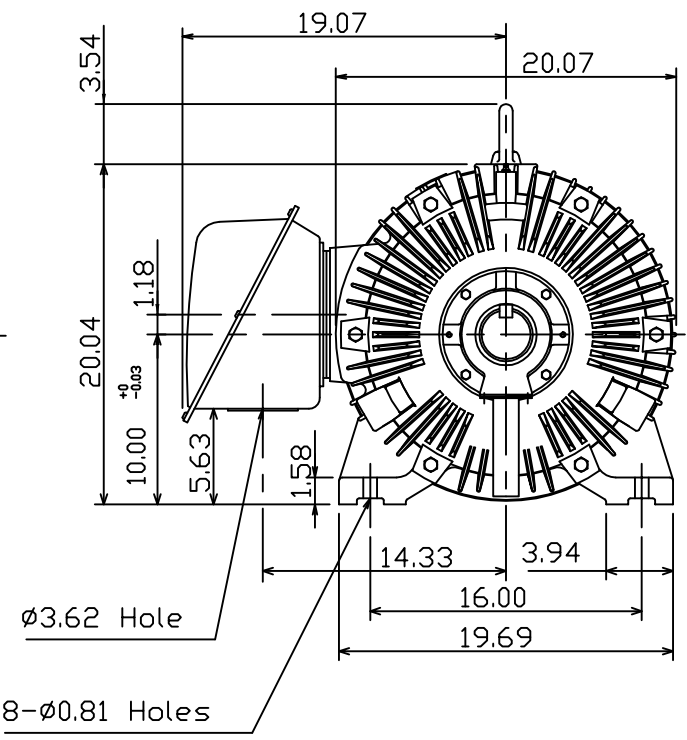
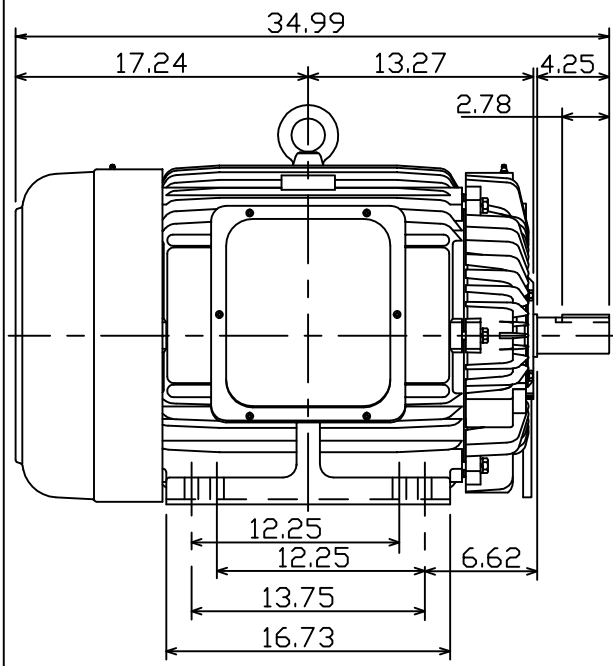

DWN.	K.L.KUD	12 06 10
CHKD.	K.L.KUD	12 07 10
APPD.	M.C.TSAI	12 07 10



DWG NO.
31049M241700