

DATE
DEC. 16, 2010
CAT. #: NP0602

OUTLINE DIMENSIONS
3-PHASE INDUCTION MOTOR

MOTOR TYPE:
AEHH8P
FRAME NO. 364TS

Pole	HP	kW	Hz	VOLT	Syn.Speed r/min(rpm)
2	60	45	50	190/380	3000

Ins	Rating	Dimension in	Approx Weight	Bearings
F	CONT.	inch	734 lbs.	DE: 6312C3 NDE: 6212C3

Totally Enclosed Fan-Cooled Type. Squirrel-Cage Rotor.

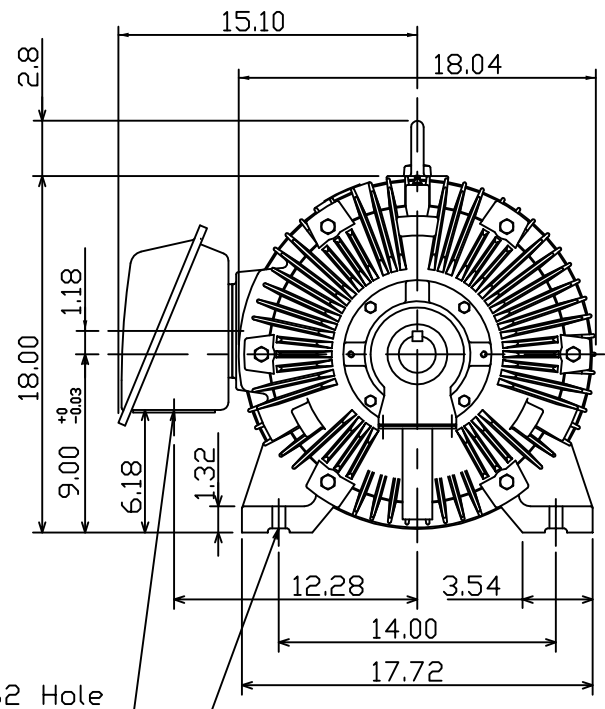
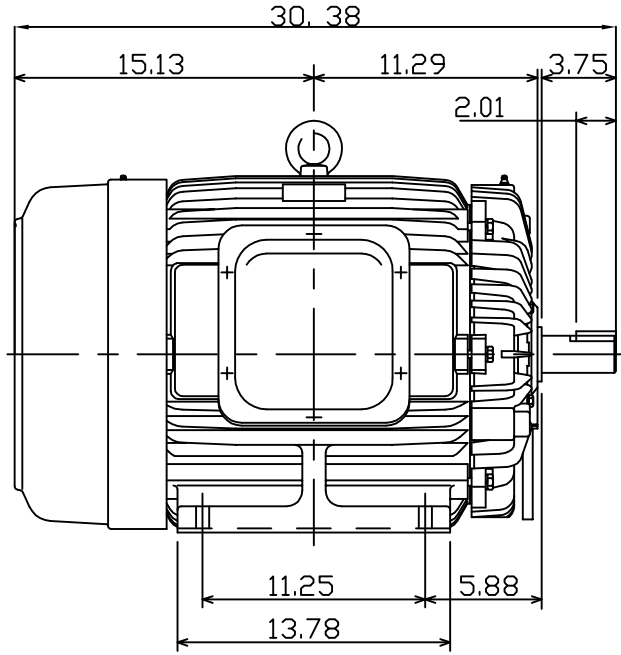

∅3.62 Hole

4-∅0.67 Holes

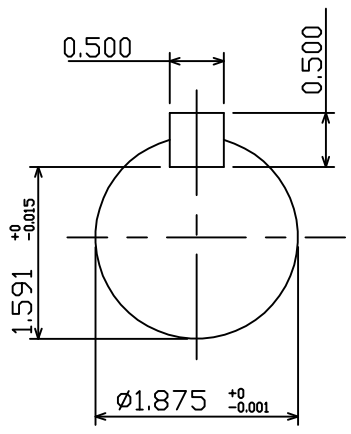

12.06.10

郭耿良

DWN, J.H.LIANG	05-20-99
CHKD, C.H.KAD	06-15-99
APPD, Y.B.HUANG	06-15-99



DWG NO.
31049M054062