

DATE
JAN. 15, 2015
CAT. #: NP0404G

OUTLINE DIMENSIONS
3-PHASE INDUCTION MOTOR

MOTOR TYPE:
AEHH8P-SGR
FRAME NO. 324T

Pole	HP	kW	Hz	VOLT	Syn.Speed r/min(rpm)
4	40	29.8	60	230/460	1800

Ins	Rating	Dimension in	Approx Weight	Bearings	
F	CONT.	inch	612 lbs.	DE: 6312	NDE: 6212

Totally Enclosed Fan-Cooled Type. Squirrel-cage Rotor.

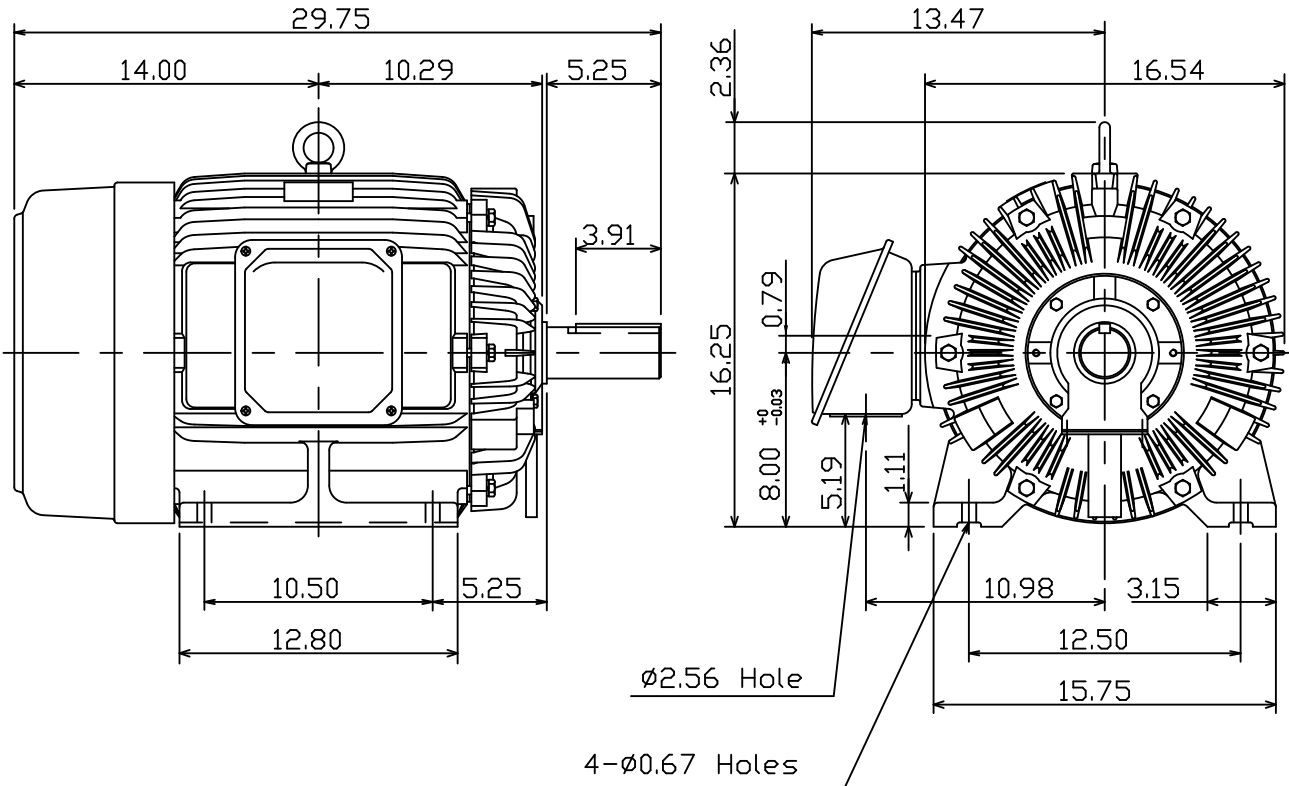

NOTE:
1. Shaft Grounding Ring installed-NDE

12.06.10 郭耿良

DWN.	J.H.LIANG	05-20-99
CHKD.	C.H.KAO	06-15-99
APPD.	Y.B.HUANG	06-15-99



DWG NO.
31049J355272