

DATE
JAN. 15, 2015
CAT. #: NP0402G

OUTLINE DIMENSIONS
3-PHASE INDUCTION MOTOR

MOTOR TYPE:
AEHH8P-SGR
FRAME NO. 324TS

Pole	HP	kW	Hz	VOLT	Syn.Speed r/min(rpm)
2	40	29.8	60	230/460	3600

Ins	Rating	Dimension in	Approx Weight	Bearings	
F	CONT.	inch	596 lbs.	DE: 6312C3	NDE: 6212C3

Totally Enclosed Fan-Cooled Type. Squirrel-cage Rotor.

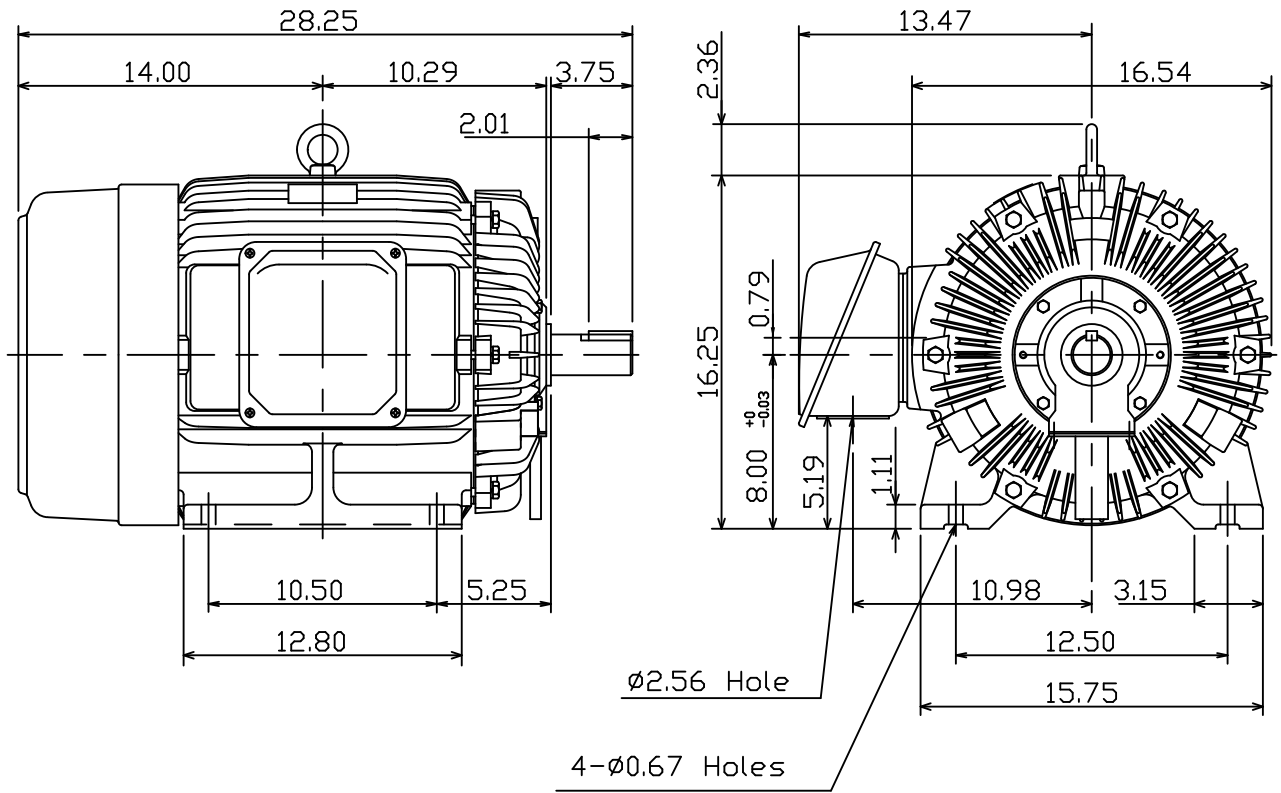

NOTE:
1. Shaft Grounding Ring installed-NDE

12.06.10 郭耿良

DWN. J.H.LIANG	05.20.99
CHKD. C.H.KAO	06.15.99
APPD. Y.B.HUANG	06.15.99



DWG NO.
31049J354013