

DATE
JAN. 15, 2015

CAT. #: NP0154G

OUTLINE DIMENSIONS

3-PHASE INDUCTION MOTOR

MOTOR TYPE:
AEHH8P-SGR

FRAME NO. 254T

Pole	HP	kW	Hz	VOLT	Syn.Speed r/min(rpm)
4	15	11.2	60	230/460	1800

Ins	Rating	Dimension in	Approx Weight	Bearings
F	CONT.	inch	267 lbs.	DE: 6309ZZ NDE: 6307ZZ

Totally Enclosed Fan Cooled Squirrel Cage Rotor.

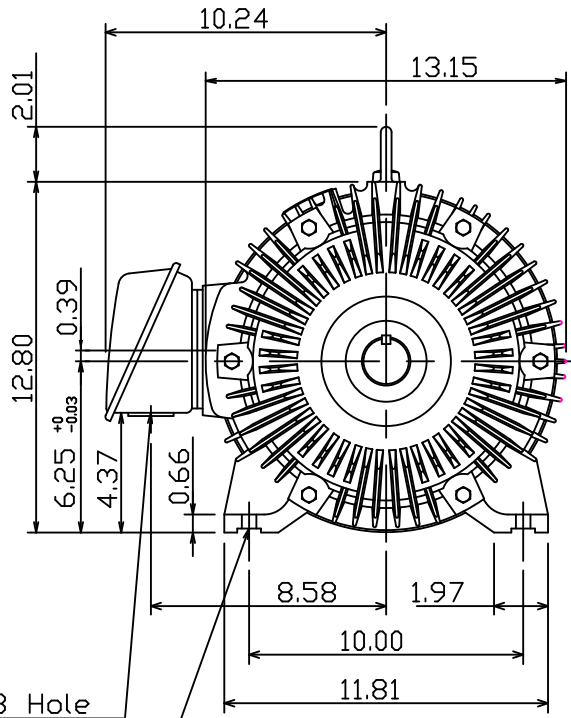
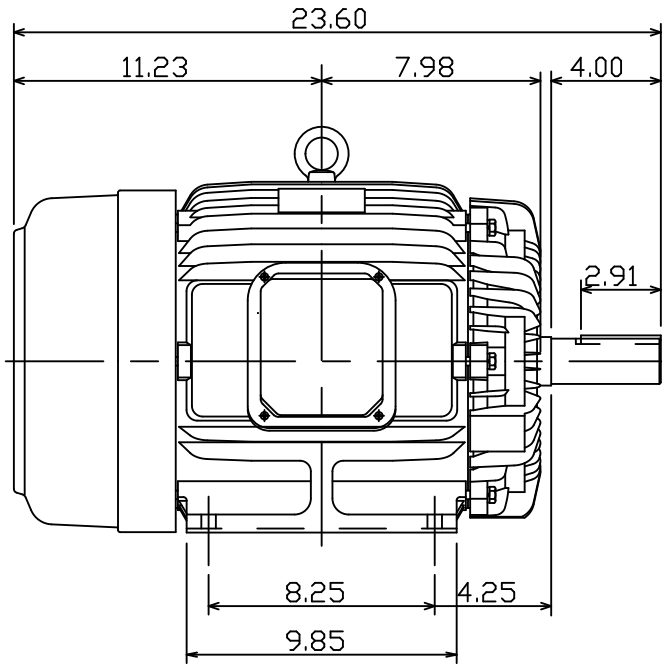

∅1.38 Hole
4-∅0.53 Holes

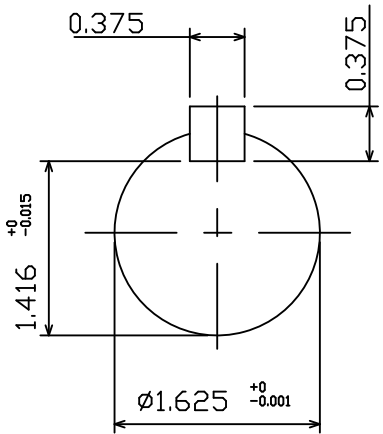

NOTE:
1. Shaft Grounding Ring installed-NDE

12.07.10 郭耿良

DWN. J.H.LIANG	05 ·20 99
CHKD. C.H.KAO	06 ·11 99
APPD. Y.B.HUANG	06 ·11 99



DWG NO.
31049J348202