

DATE
JAN. 15, 2015
CAT. #: NP0102G

OUTLINE DIMENSIONS
3-PHASE INDUCTION MOTOR

MOTOR TYPE:
AEHH8P-SGR
FRAME NO. 215T

Pole	HP	kW	Hz	VOLT	Syn.Speed r/min(rpm)
2	10	7.5	60	230/460	3600
Ins	Rating	Dimension in	Approx Weight	Bearings	
F	CONT.	inch	176 lbs.	DE: 6308ZZ NDE: 6306ZZ	

Totally Enclosed Fan-Cooled Type, Squirrel-Cage Rotor.

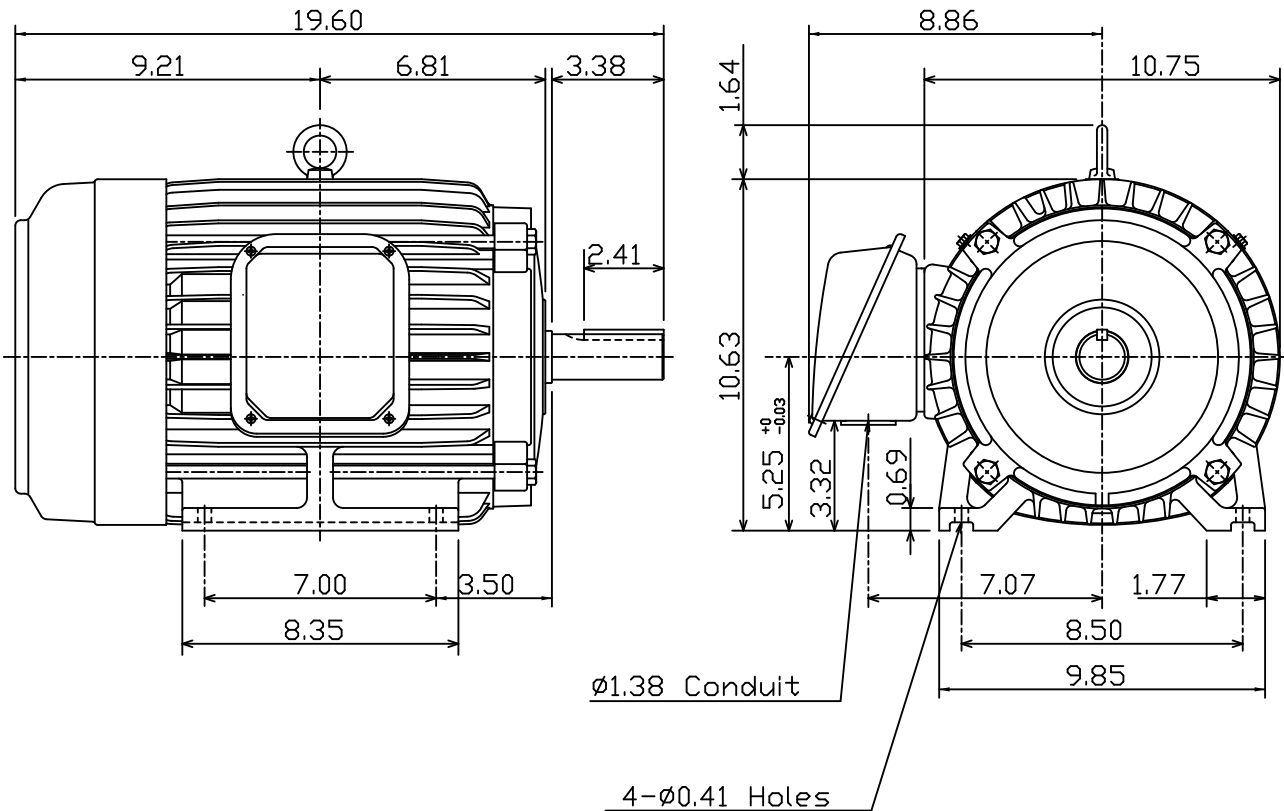

NOTE:
1. Shaft Grounding Ring installed-NDE



DWN.	J.H.LIANG	05-20-99
CHKD.	C.S.LO	05-26-99
APPD.	Y.B.HUANG	05-26-99

TECO Westinghouse

DWG NO.
31049D192410