

TYPE	OUTPUT		POLE	TIME RATING	VOLTAGE V	Hz	SYN.SPEED R.P.M
	HP.	kW.					
AEHGTK	450	336	4	CONT.	2300/4160	60	1800

TOTALLY ENCLOSED FAN-COOLED TYPE, SQUIRREL-CAGE ROTOR

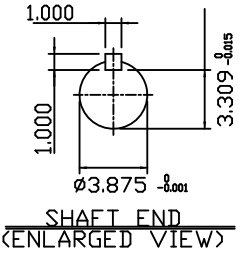
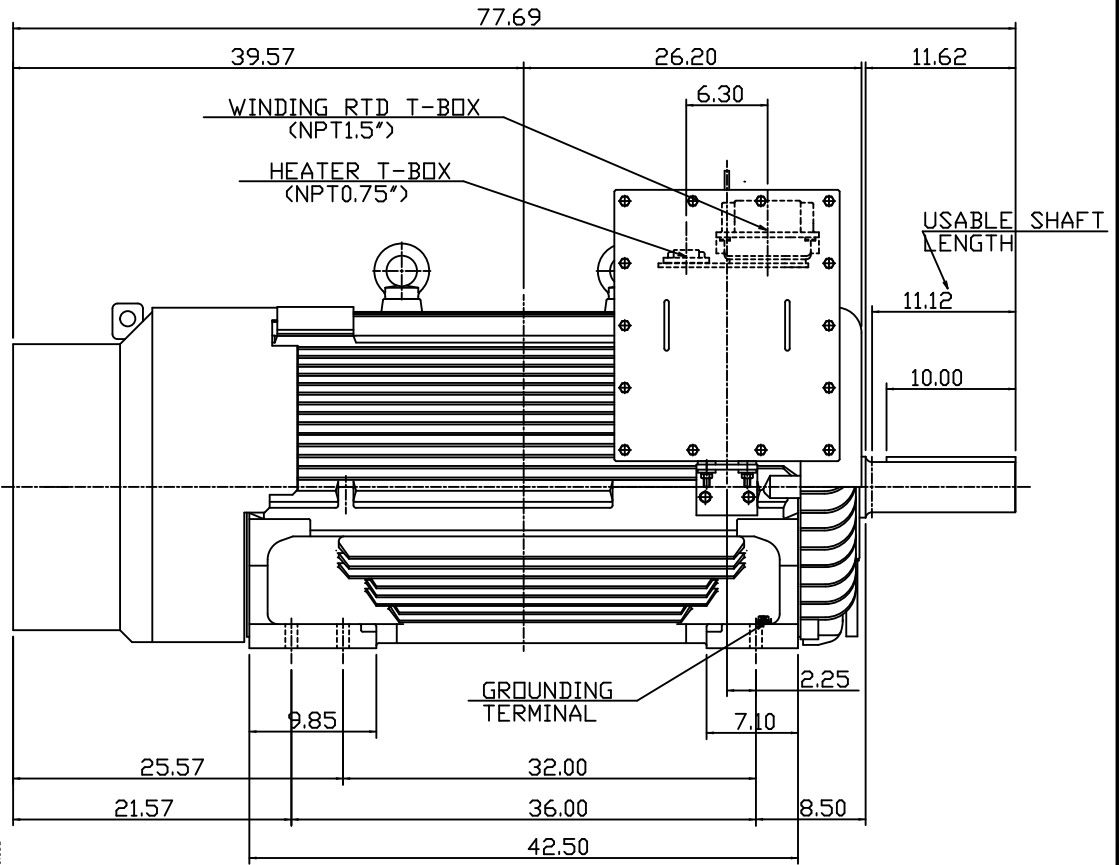
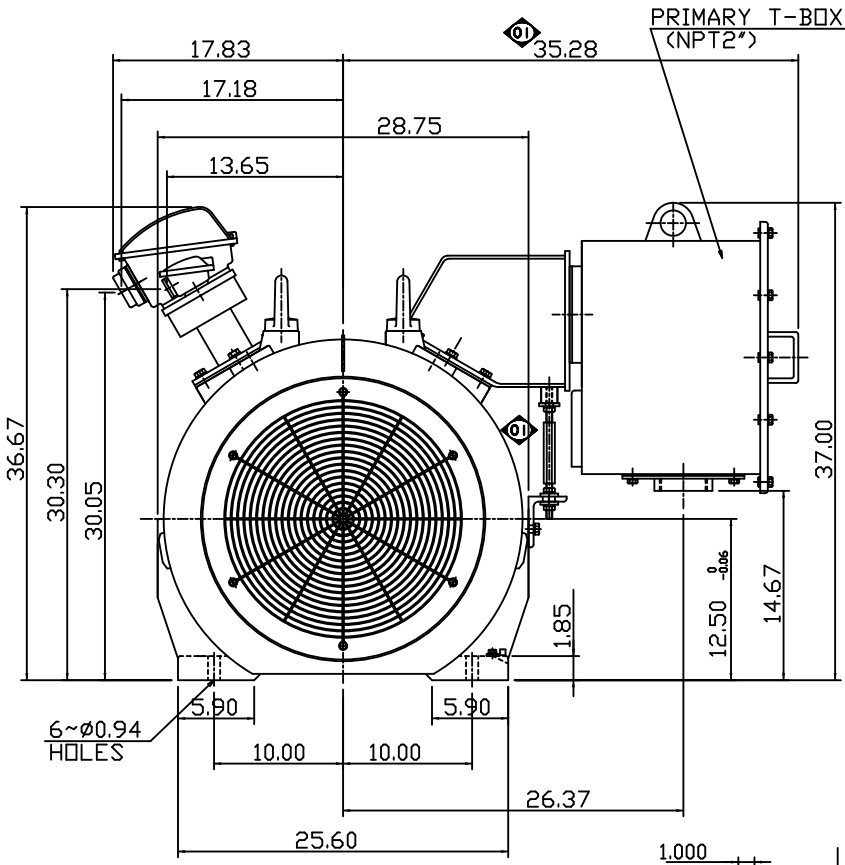

- NOTE:
- DIMENSIONS IN INCH
 - FRAME NO. 5011B(5010B)
 - F CLASS INSULATION,S.F.1.15
 - FOR DIRECT FLEXIBLE COUPLING
 - ENCLOSURE: IP54
 - WITH SPACE HEATER & WINDING RTD
 - BEARING SIZE: DRIVE-END 6324
OPP. DRIVE-END 6320
 - MOTOR APPROX. WEIGHT: 4800LBS

DATE	OCT. 31, 2014	OUTLINE DIMENSIONS
CATALOG #	KG4504	3-PHASE INDUCTION MOTOR
DWN.	F.FAN	AUG-31-2011
CHKD.	H.HUANG	AUG-31-2011
APPD.	B.LIN	AUG-31-2011
TECO Westinghouse		DWG NO. REV: 01
		4A040G946