

TYPE	OUTPUT		POLE	TIME RATING	VOLTAGE	Hz	SYN.SPEED
	HP	KW					
AEJHTK	1500	1100	6	CDNT.	2300/4160	60	1200

TOTALLY ENCLOSED FAN COOLED TYPE, SQUIRREL CAGE ROTOR

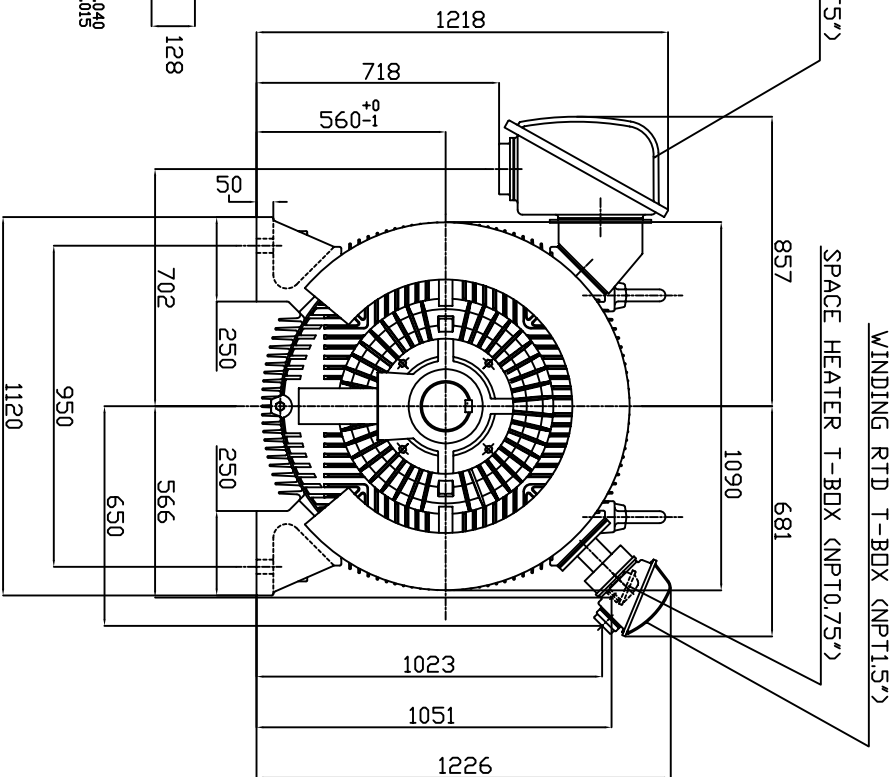
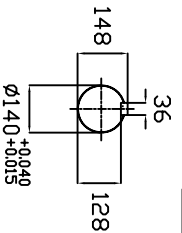
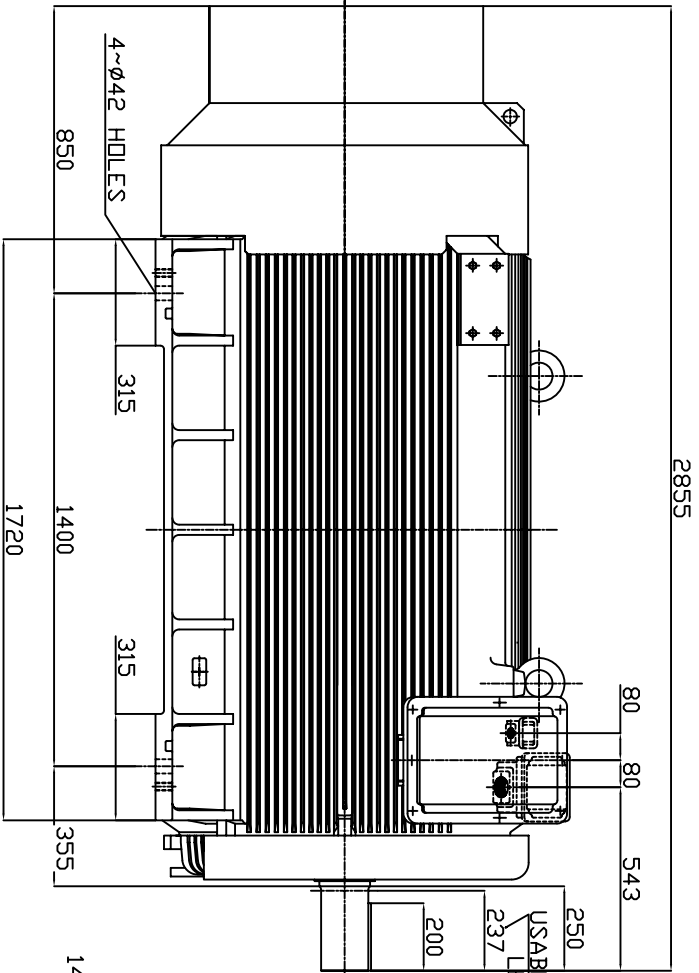

PRIMARY T-BOX (NPT5")

SPACE HEATER T-BOX (NPT0.75")

WINDING RTD T-BOX (NPT1.5")

1. DIMENSIONS IN MM
2. FRAME NO. 560C
3. F CLASS INSULATION
4. FOR DIRECT FLEXIBLE COUPLING
5. WITH SPACE HEATER 120 VOLT SINGLE PHASE 500 WATTS
6. WITH 100 OHM PLATINUM WINDING RTD'S 2/PHASE
7. BEARING SIZE: DRIVE END: 6330 NON-DRIVE END: 6326M/C3 VL024
8. MOTOR APPROX. WEIGHT: 8200 KGS

TW-66C

DWN.	W.LLIN	DATE
CHKD.	W.LLIN	APR. 22. 2003
APPD.	C.WANG	APR. 22. 2003

DATE	OUTLINE	DIMENSIONS
MAY 7, 2004	3-PHASE INDUCTION MOTOR	

CATALOG NO. JH15006

DWG NO. 3A040T4111



REV: 00