

TYPE	OUTPUT		POLE	TIME RATING	VOLTAGE	Hz	SYN.SPEED R.P.M
	HP	KW					
AEJHTK	1000	746	4	CDNT.	2300/4160	60	1800

TOTALLY ENCLOSED FAN COOLED TYPE, SQUIRREL CAGE ROTOR

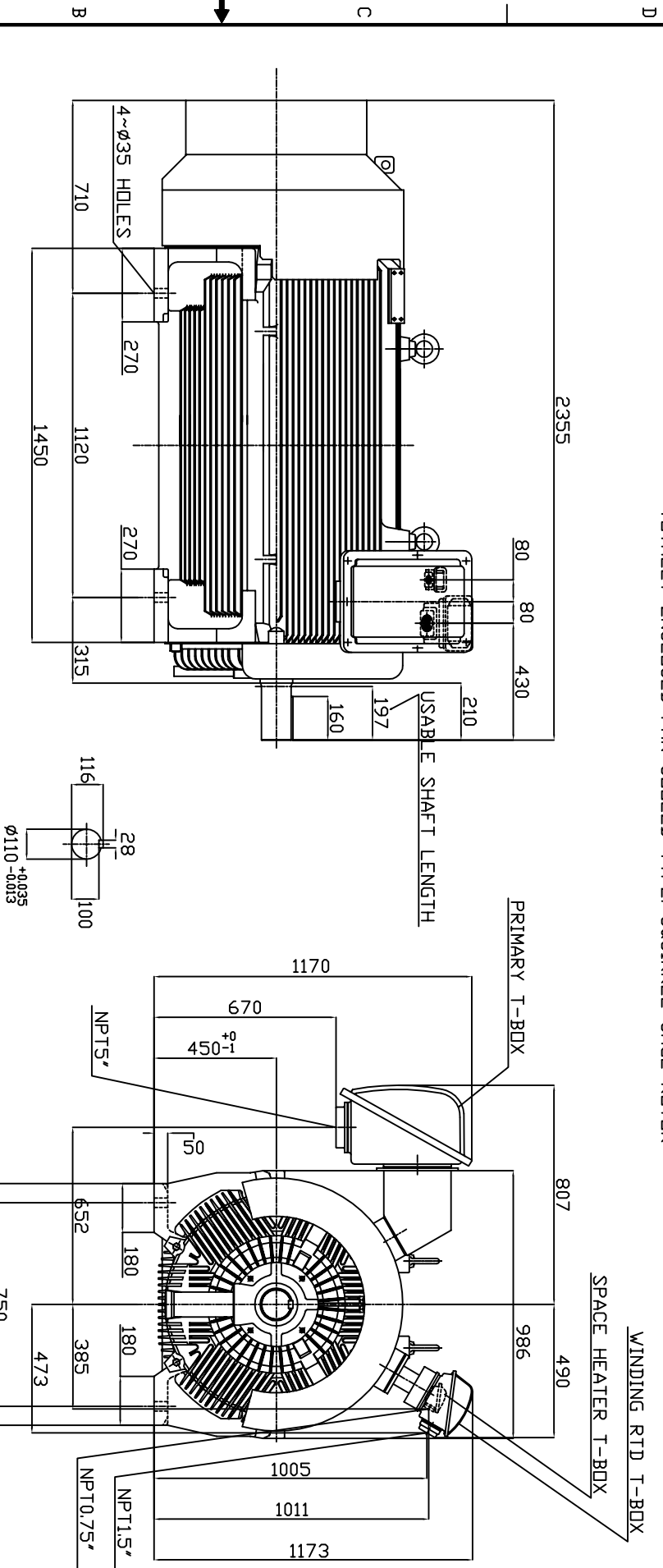

NOTE:

1. DIMENSIONS IN MM
2. FRAME ND. 450C
3. F CLASS INSULATION
4. FOR DIRECT FLEXIBLE COUPLING
5. WITH SPACE HEATER 120 VOLT SINGLE PHASE 300 WATTS
6. WITH 100 OHM PLATINUM WINDING RTD'S 2/PHASE
7. BEARING SIZE: DRIVE END: 6324
NON-DRIVE END: 6322
8. MOTOR APPROX. WEIGHT: 4500 KGS

TW-66C

DWN.	W.L.LIN	APR-22-2003
CHKD.	W.L.LIN	APR-22-2003
APPD.	C.WANG	APR-22-2003

DATE	OUTLINE DIMENSIONS
MAY 7, 2004	3-PHASE INDUCTION MOTOR
CATALOG NO. JH10004	

DWG NO.	REV.
3A040T4072	00

