

TYPE	OUTPUT		POLE	TIME RATING	VOLTAGE V	Hz	SYN. SPEED R. P. M
	HP.	kW.					
AFJH-S2	1000		2	CONT.	2300/4160	60	3600

TOTALLY ENCLOSED FAN-COOLED TYPE. SQUIRREL-CAGE ROTOR

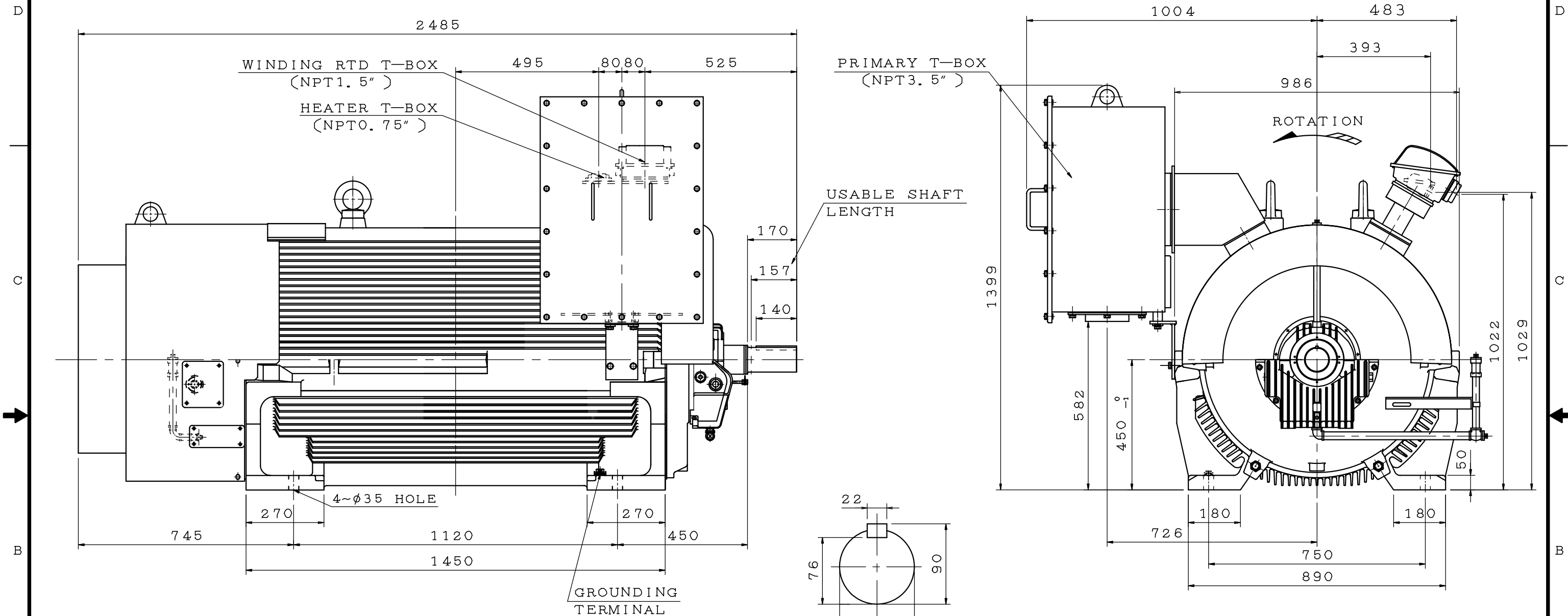

- NOTE:
- DIMENSIONS IN MM
  - FRAME NO. 450CA
  - F CLASS INSULATION, S. F. 1.15
  - ENCLOSURE: IP54
  - BEARING SIZE: DRIVE END: 9S-80 (UNINSULATED)  
OPP. DRIVE END: 9S-80 (INSULATED)
  - THE NON-DRIVE END BEARING LINER (SHELL) IS INSULATED FROM THE HOUSING. METAL CONNECTIONS MADE TO THE BEARING SHELL MUST BE INSULATED TO PREVENT AN INSULATION SHORT CIRCUIT. METAL CONNECTIONS MADE TO THE HOUSING DO NOT NEED TO BE INSULATED.
  - BEARING LUBRICATION: SELF-LUBRICATION  
A. OIL VISCOSITY: ISO VG32  
B. OIL CAPACITY: 2.4L FOR EACH BEARING
  - SLEEVE TYPE BEARING, AXIAL THRUST LOAD NOT ALLOWED
  - THE MOTOR ENDPLAY IS ±7MM. A LIMITED END FLOAT TYPE COUPLING IS REQUIRED TO LIMIT ENDPLAY TO ±2.4MM
  - WITH SPACE HEATER: 1φ 120V 300W
  - WITH WINDING RTD: PT 100Ω/0°C 6PCS
  - PROVISION FOR BEARING RTD
  - APPROX. WEIGHT: 4800KGS

DATE	OUTLINE DIMENSIONS	
	3-PHASE INDUCTION MOTOR	

DWN.	C. WANG	NOV.11.2010
CHKD.	B. LIN	NOV.18.2010
APPD.	B. YANG	NOV.18.2010

**TECO** Westinghouse

DWG NO. 4A040C506 REV:00