

TYPE	OUTPUT HP. KW.	POLE	TIME RATING CONT.	VOLTAGE V	Hz	SYNSPEED R.P.M
AEHH	200 149.2	4		380	50	1500

TOTALLY ENCLOSED FAN-COOLED TYPE, SQUIRREL-CAGE ROTOR

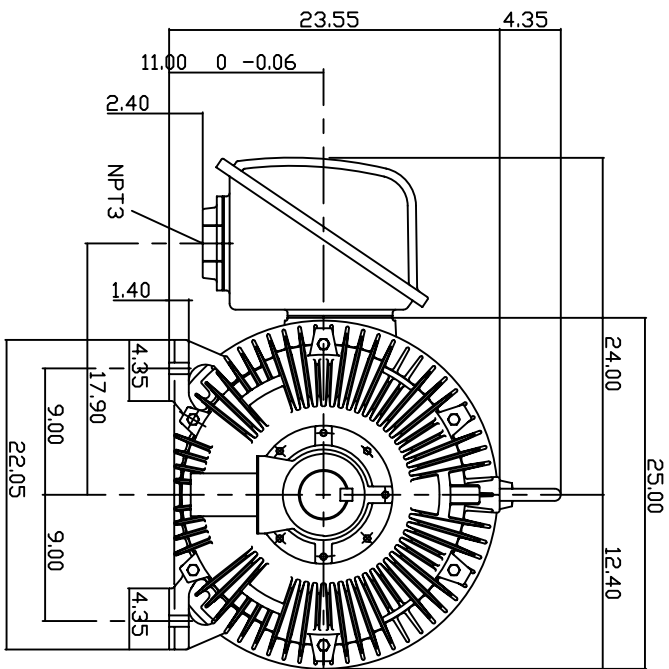
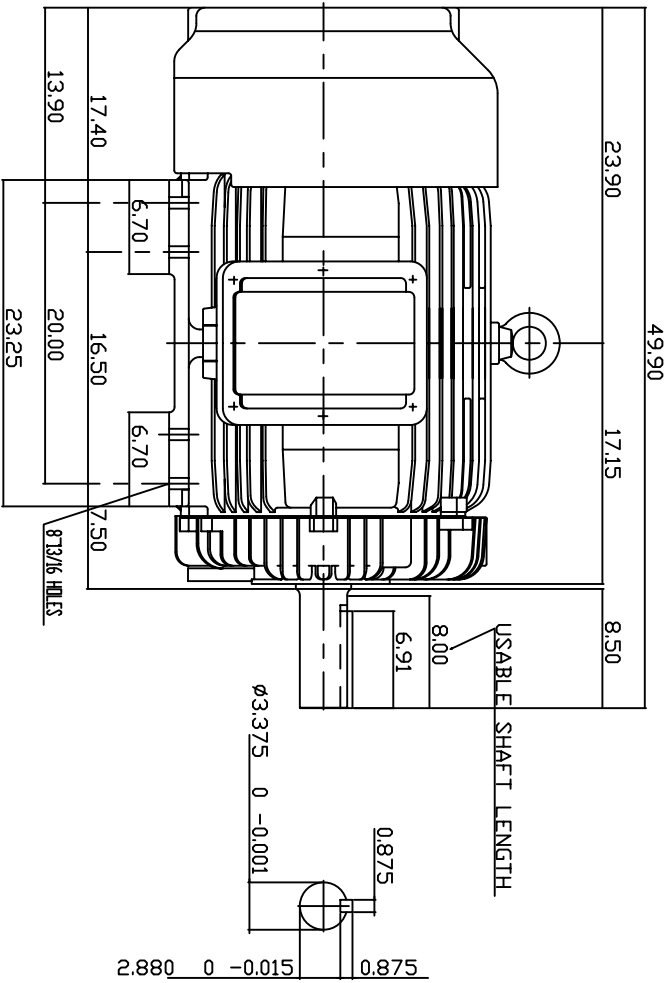

NOTE:

1. DIMENSIONS IN INCH
2. FRAME NO. 447T
3. F CLASS INSULATION, S.F.10
4. FOR DIRECT FLEXIBLE COUPLING
5. ENCLOSURE: IP55
6. BEARING SIZE: DRIVE END: 6320C3  
NON-DRIVE END: 6316C3
7. APPROX. WEIGHT: 2500 LBS
8. NON-SPARKING FAN.
9. NOISE: BELOW 83 DBA AT 1 METER, NO LOAD.

TW-56C

DWN.	T.H.Pan	DATE
CHKD.	H.HUANG	FEB 18 2005
APPD.	C.WANG	FEB 18 2005

DATE: 06-20-05  
 CAT. #: HH2004-50  
 OUTLINE DIMENSIONS  
 3-PHASE INDUCTION MOTOR

TECO Westinghouse  
 Dwg No. 3A040Y700  
 REV: 00