

TYPE	OUTPUT		POLE	TIME RATING CDNT.	VOLTAGE V	Hz	SYNSPEED R.P.M
	HP.	KW.					
AEHH	200	149.2	2		460	60	3600

TOTALLY ENCLOSED FAN-COOLED TYPE, SQUIRREL-CAGE ROTOR

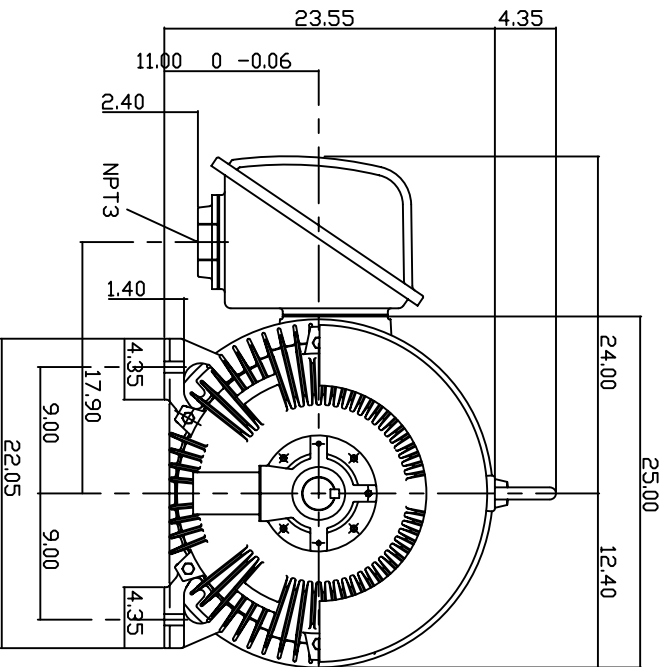
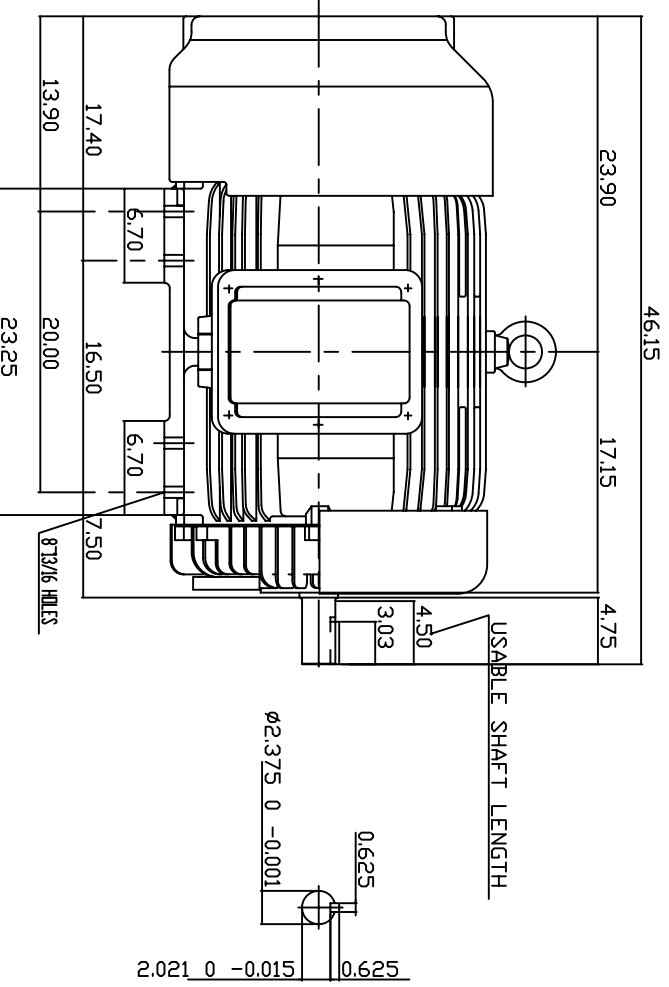

NOTE:

1. DIMENSIONS IN INCH
2. FRAME NO. 447TS
3. F CLASS INSULATION, S.F.115
4. FOR DIRECT FLEXIBLE COUPLING
5. ENCLOSURE: IP55
6. BEARING SIZE: DRIVE END: 6314C3
NON-DRIVE END: 6314C3
7. APPROX. WEIGHT: 1900 LBS
8. NON-SPARKING FAN.
9. NOISE: BELOW 83 DBA AT 1 METER, NO LOAD.

TW-56C

DWN.	T.H.Pan	DATE
CHKD.	H.HUANG	FEB 18 2005
APPD.	C.WANG	FEB 18 2005

DATE	OUTLINE DIMENSIONS
06-20-05	3-PHASE INDUCTION MOTOR
CATALOG #HH2002	

Westinghouse
D/WG NO. 3A040Y701
REV. 00