

TYPE	OUTPUT		POLE	RATING	VOLTAGE	Hz	SYNSPEED R.P.M
	HP.	KW.					
AEHH	125	93.3	6	CDNT.	460	60	1200

TOTALLY ENCLOSED FAN-COOLED TYPE, SQUIRREL-CAGE ROTOR

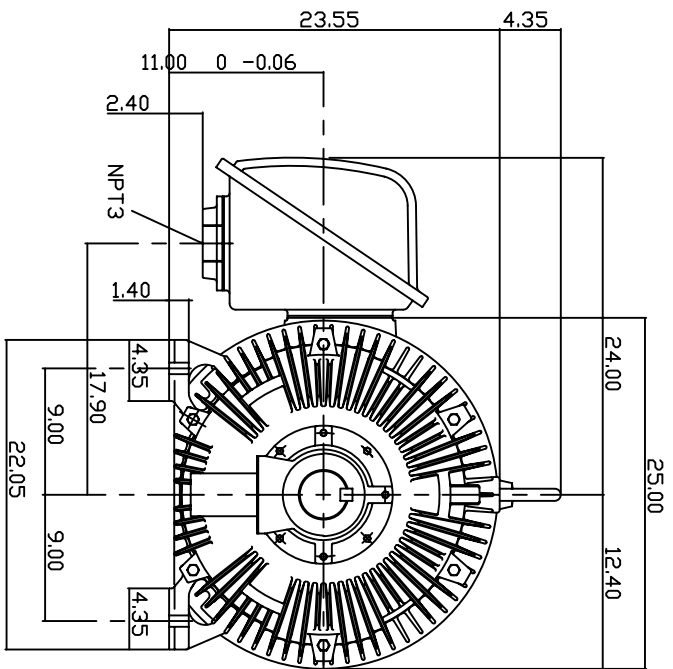
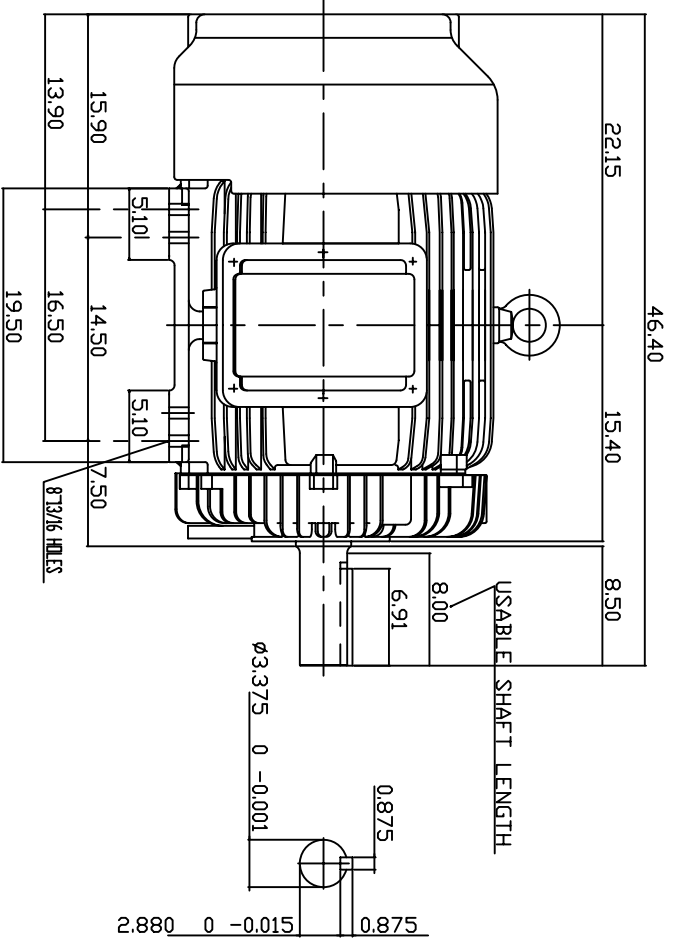

NOTE:

1. DIMENSIONS IN INCH
2. FRAME NO. 445T
3. F CLASS INSULATION, S.F.115
4. FOR DIRECT FLEXIBLE COUPLING
5. ENCLOSURE: IP55
6. BEARING SIZE DRIVE END: 6318C3
NON-DRIVE END: 6316C3
7. APPROX. WEIGHT: 1850 LBS
8. NON-SPARKING FAN.
9. NOISE: BELOW 83 DBA AT 1 METER, NO LOAD.

TW-56C

DWN.	T.H.Pan	FEB 18 2005
CHKD.	H.HUANG	FEB 18 2005
APPD.	C.WANG	FEB 18 2005

DATE	06-20-05	OUTLINE DIMENSIONS
CATALOG #	HH1256	3-PHASE INDUCTION MOTOR

TECO Westinghouse
D/WG NO. 3A040Y698
REV. 00