

DATE  
January 21, 2009  
CAT. #:

OUTLINE DIMENSIONS  
3-PHASE INDUCTION MOTOR

MOTOR TYPE:  
AEUH8B-DC  
FRAME NO. 364TC

Pole	HP	kW	Hz	VOLT	Syn.Speed r/min(rpm)
4/6/8	.	.	.	.	.

Ins	Rating	Dimension in	Approx Weight	Bearings
F	CONT.	inches	925 LBS	DE: 6313ZC3 NDE: 6212ZC3

Totally Enclosed Fan-Cooled Type. Squirrel-Cage Rotor.

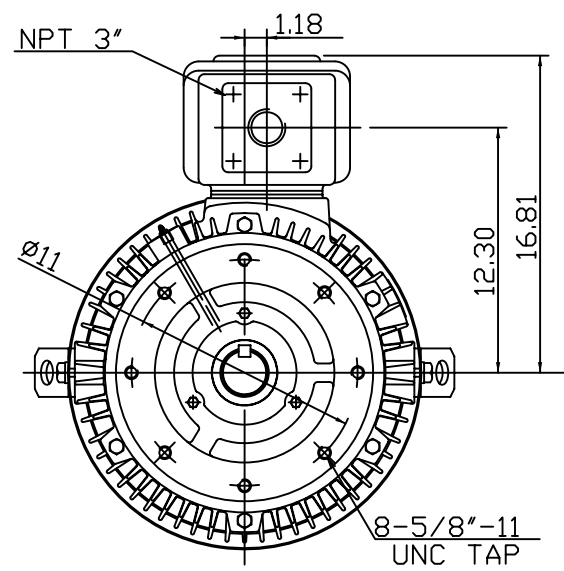
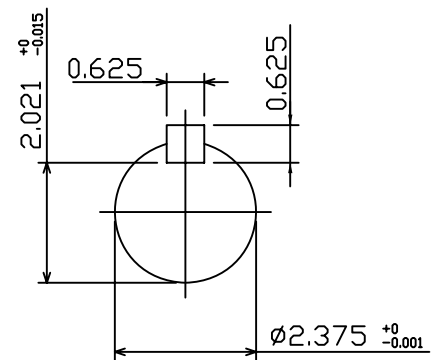
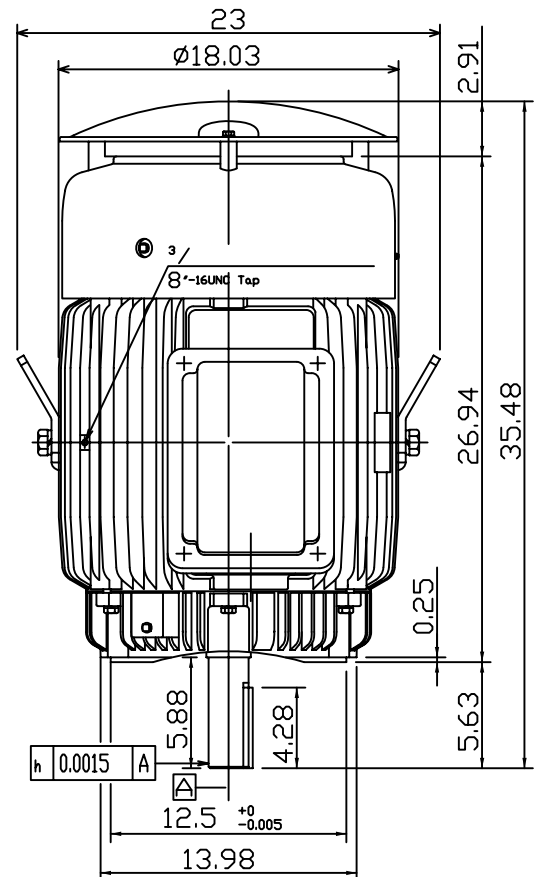

Note:  
1. C/W Inpro/Seal In Both End Brackets.  
2. Motor Vibration:15?

0	.	.
---	---	---

DWN.	???????	01 01 09
CHKD.	???????	01 02 09
APPD.	???????	01 02 09



DWG NO.  
31057H178740