

6 5 4 3 2 1

TYPE	OUTPUT		POLE	TIME RATING	VOLTAGE V	Hz	SYN.SPEED R.P.M
	HP.	kW.					
AEHH-8B	450	336	8	CONT.	460	60	900

TOTALLY ENCLOSED FAN-COOLED TYPE, SQUIRREL-CAGE ROTOR

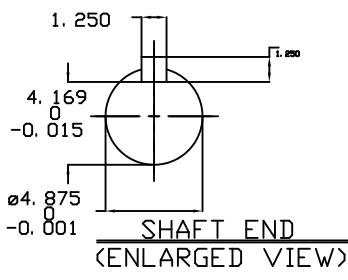
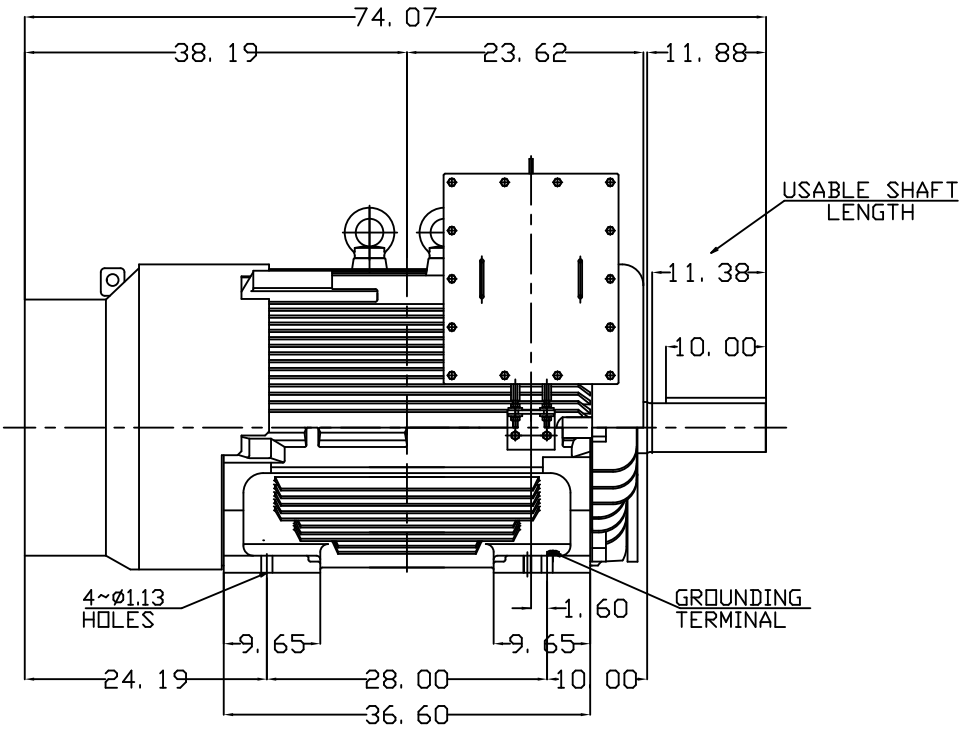
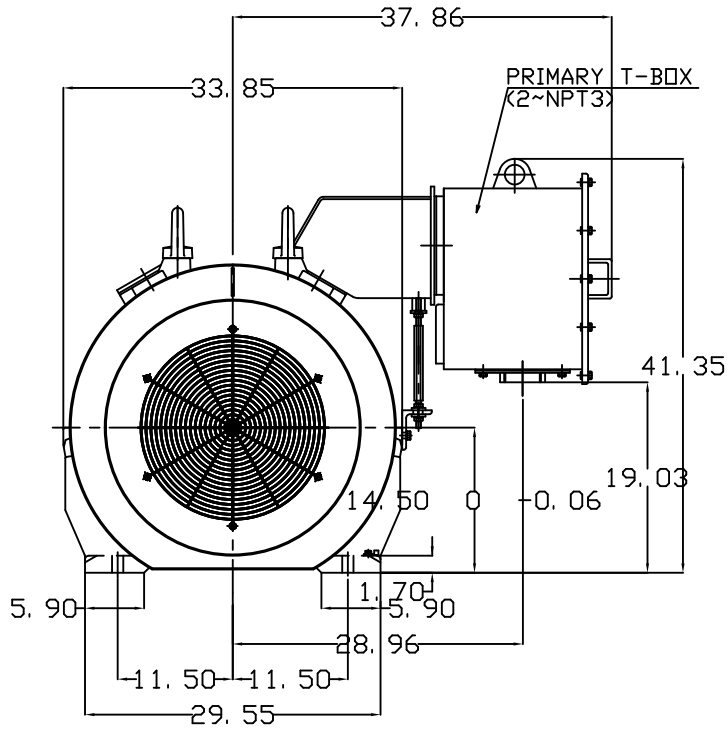

- NOTE:
1. DIMENSIONS IN inch
 2. FRAME NO. 5808B
 3. F CLASS INSULATION, S.F.1.15
 4. FOR DIRECT FLEXIBLE COUPLING
 5. ENCLOSURE: IP55
 6. BEARING SIZE: DRIVE-END 6326C3
OPP. DRIVE-END 6322C3
 7. BOTH ENDS BEARING ARE INPRO SEAL
 8. NON-SPARKING FAN
 9. MOTOR APPROX. WEIGHT: 5600 lb

DWN.	J.WU	APR-14-2014
CHKD.	W.CHENG	APR-28-2014
APPD.	C.SHIH	APR-28-2014

DATE	3-25-2015	OUTLINE DIMENSIONS	
	HB4508	3-PHASE INDUCTION MOTOR	
TEC Westinghouse		DWG NO.	REV:00
		4B040C151	

6 5 4 3 2 1