

DATE  
January 20, 2009  
CAT. #:

OUTLINE DIMENSIONS  
3-PHASE INDUCTION MOTOR

MOTOR TYPE:  
AEHH8B-CF  
FRAME NO. 284TSC

Pole	HP	kW	Hz	VOLT	Syn.Speed r/min(rpm)
2					

Ins	Rating	Dimension in	Approx Weight	Bearings
F	CONT.	inches	430 LBS	DE: 6311ZC3 NDE: 6310ZC3

Totally Enclosed Fan Cooled Type. Squirrel-cage Rotor.

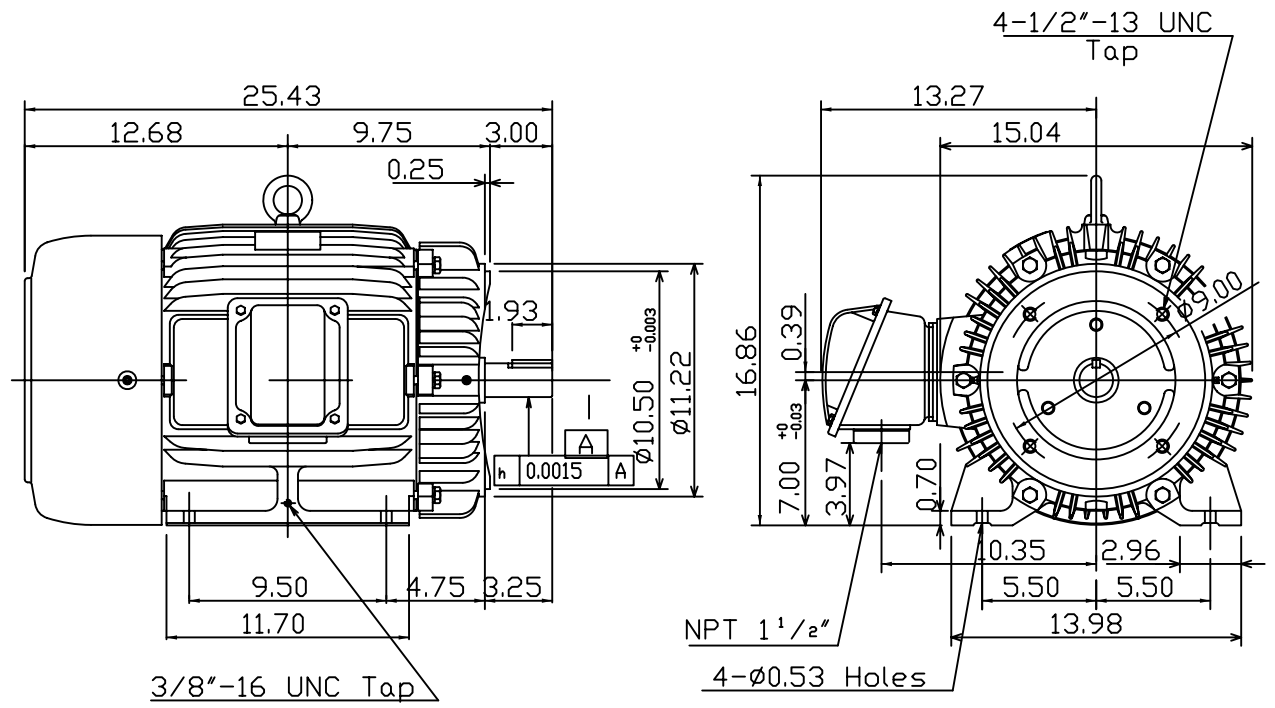

- Note:
1. Motor Vibration:10?
  2. Inpro/Seal in Both End Brackets

① 01.03.09

DWN.	???????	01 19 05
CHKD.	???????	01 02 09
APPD.	???????	01 02 09



DWG NO.  
31049M627401