

DATE  
OCTOBER 19, 2010  
CAT. #: GP0036C

OUTLINE DIMENSIONS  
3-PHASE INDUCTION MOTOR

MOTOR TYPE:  
AEGHCF  
FRAME NO. 213TC

Pole	HP	kW	Hz	VOLT	Syn.Speed r/min(rpm)
6	3	2.24	60	230/460	1200

Ins	Rating	Dimension in	Approx Weight	Bearings
F	CONT.	inches	164	DE: 6208ZZ NDE: 6206ZZ

Totally Enclosed Fan-Cooled Type, Squirrel-Cage Rotor.

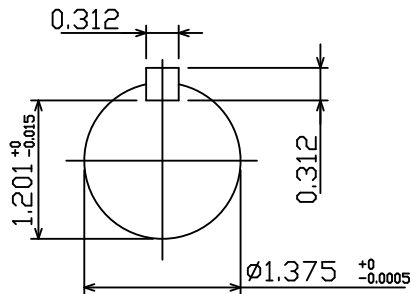
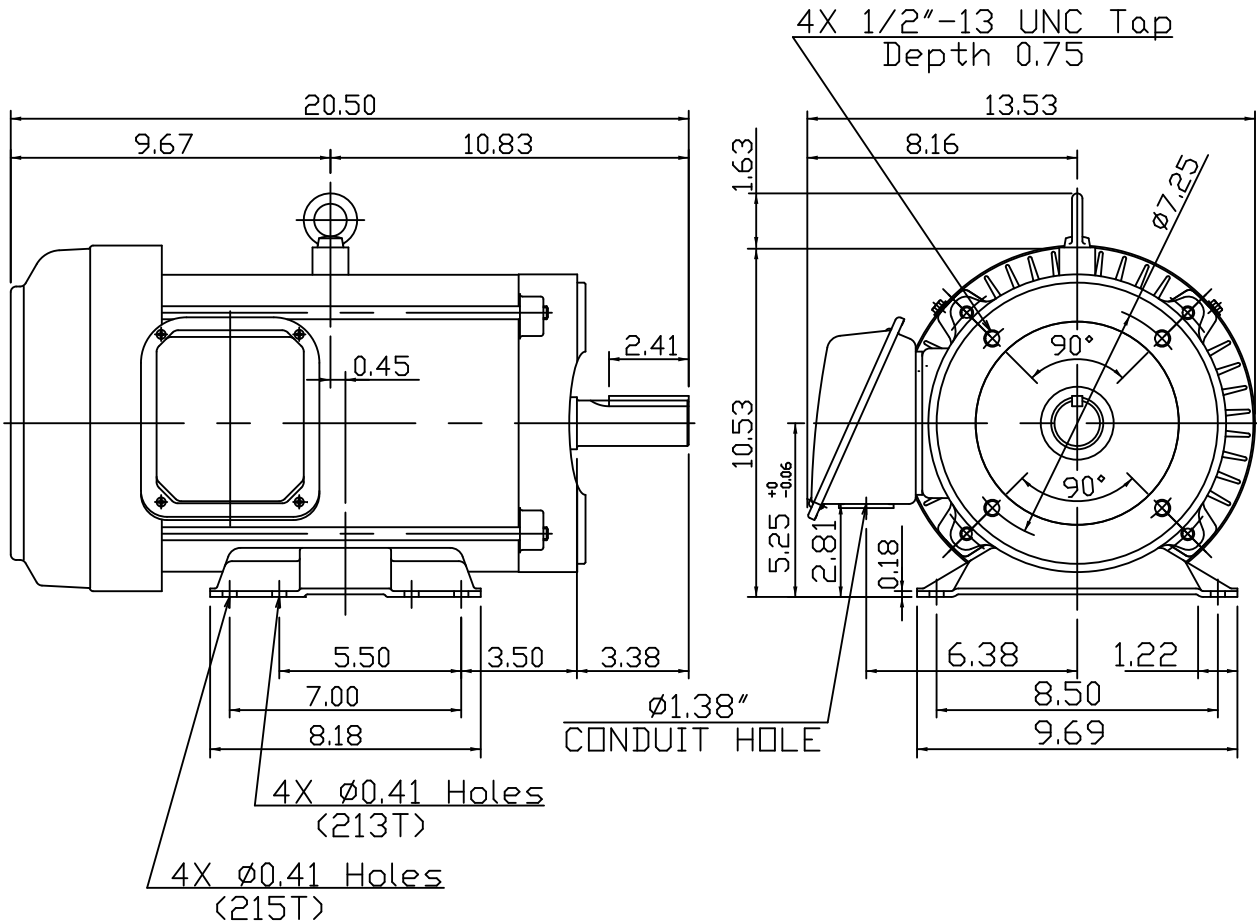

DWN.	Y.S.LIN	10 05 09
CHKD.	J.H.LIANG	10 06 09
APPD.	M.C.TSAI	10 06 09



DWG NO.  
31049R173020