

TYPE	OUTPUT		POLE	TIME RATING	VOLTAGE V	Hz	SYN.SPEED R.P.M
	HP.	KW.					
AEHH8N	300	224	2	CONT.	460	60	3600

TOTALLY ENCLOSED FAN-COOLED TYPE. SQUIRREL-CAGE ROTOR

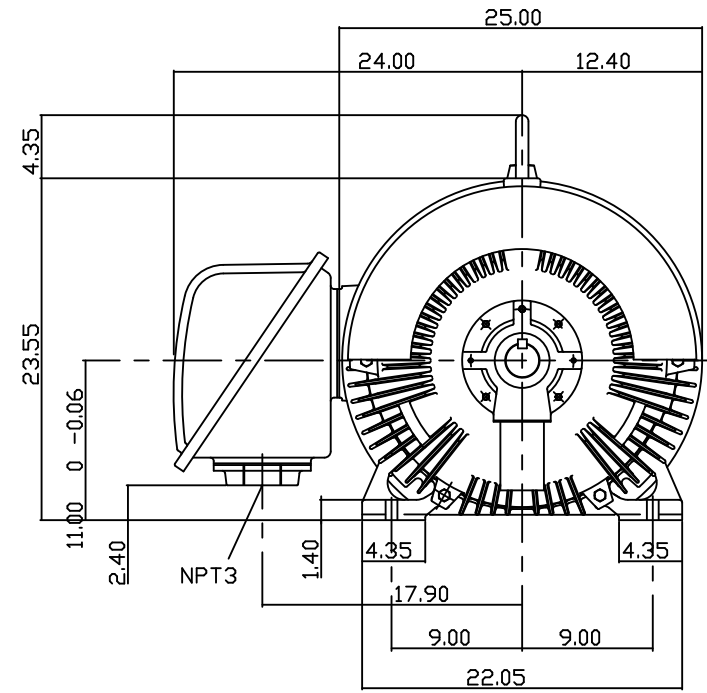
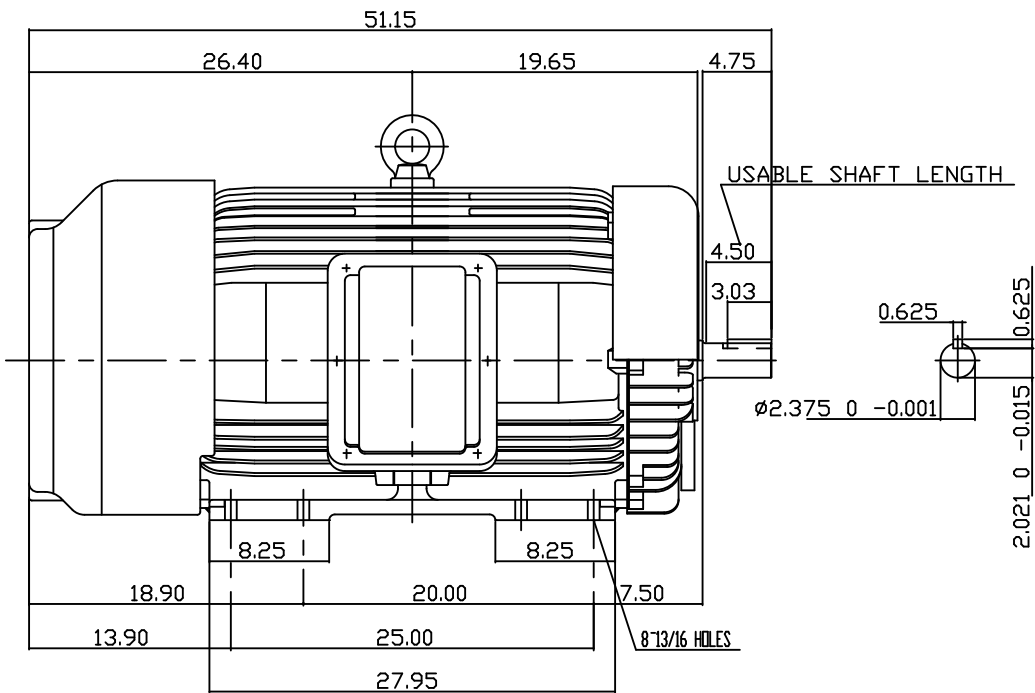

- NOTE:
1. DIMENSIONS IN INCH
 2. FRAME NO. 449TS
 3. F CLASS INSULATION, S.F.115
 4. FOR DIRECT FLEXIBLE COUPLING
 5. ENCLOSURE: IP54
 6. BEARING SIZE: DRIVE END: 6314C3
NON-DRIVE END: 6314C3
 7. APPROX. WEIGHT: 3100 LBS

TW-56C

DWN.	T.H.Pan	FEB 17 2005
CHKD.	H.HUANG	FEB 17 2005
APPD.	C.WANG	FEB 17 2005

DATE 20140616	OUTLINE DIMENSIONS
CATALOG # EP3002	3-PHASE INDUCTION MOTOR
TEC Westinghouse	
DWG NO. 3A040Y686	REV: 00