

TYPE	OUTPUT		POLE	TIME RATING	VOLTAGE	Hz	SYN SPEED R.P.M
	HP.	KW.					
AEH8N	300	223.8	2	CONT.	380	50	3000

TOTALLY ENCLOSED FAN-COOLED TYPE, SQUIRREL-CAGE ROTOR

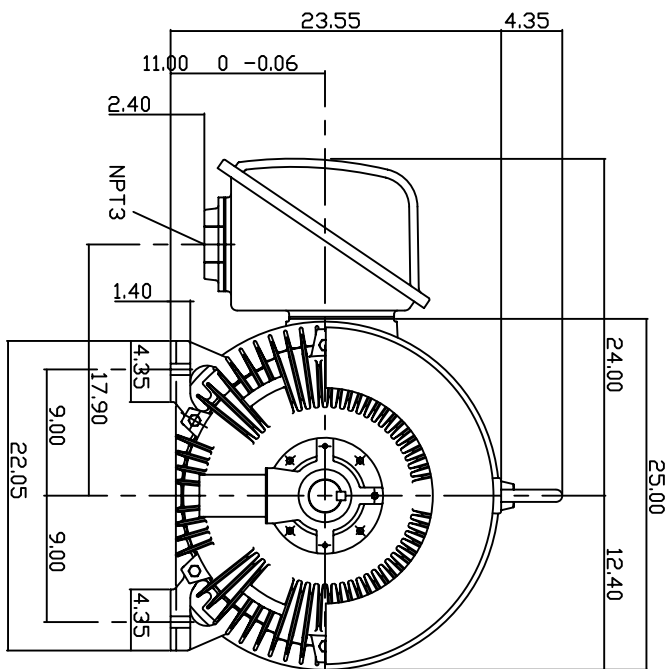
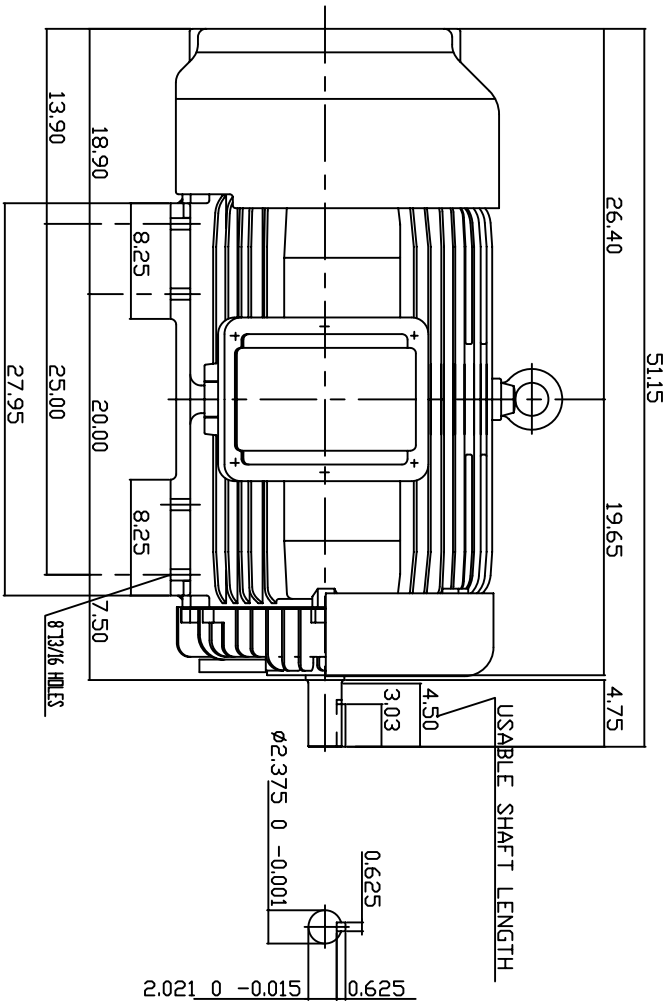

NOTE:

1. DIMENSIONS IN INCH
2. FRAME NO. 449TS
3. F CLASS INSULATION, S.F.115
4. FOR DIRECT FLEXIBLE COUPLING
5. ENCLOSURE: IP54
6. BEARING SIZE: DRIVE END: 6314C3
NON-DRIVE END: 6314C3
7. APPROX. WEIGHT: 3100 LBS

TW-56C

DWN.	T.H.Pan	FEB 17 2005
CHKD.	H.HUANG	FEB 17 2005
APPD.	C.WANG	FEB 17 2005

DATE 20050616

OUTLINE DIMENSIONS

CAT. # EP3002-50

3-PHASE INDUCTION MOTOR

DWG NO. REV: 00



3A040Y686