

TYPE	OUTPUT HP.	OUTPUT KW.	POLE	RATING CNT.	VOLTAGE V	Hz	SYNSPEED R.P.M
AEH8N	150	111.9	6	380	50	1000	

TOTALLY ENCLOSED FAN-COOLED TYPE, SQUIRREL-CAGE ROTOR

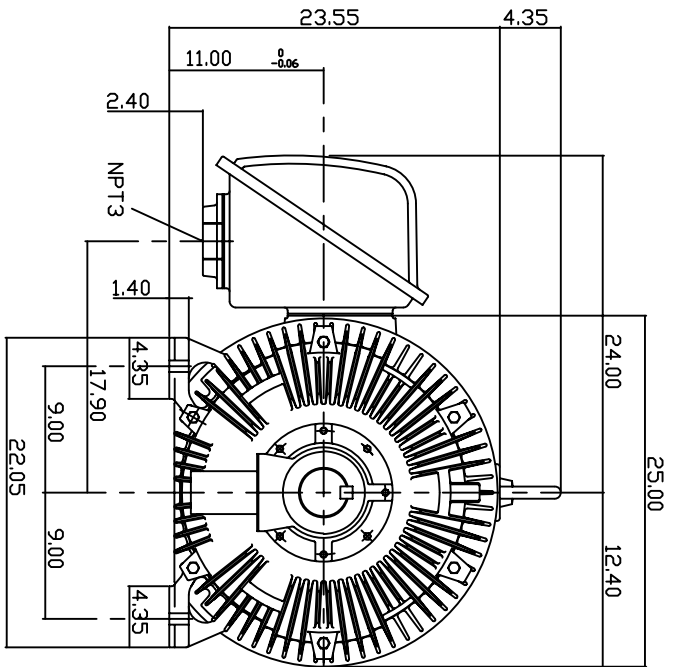
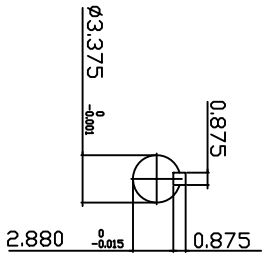
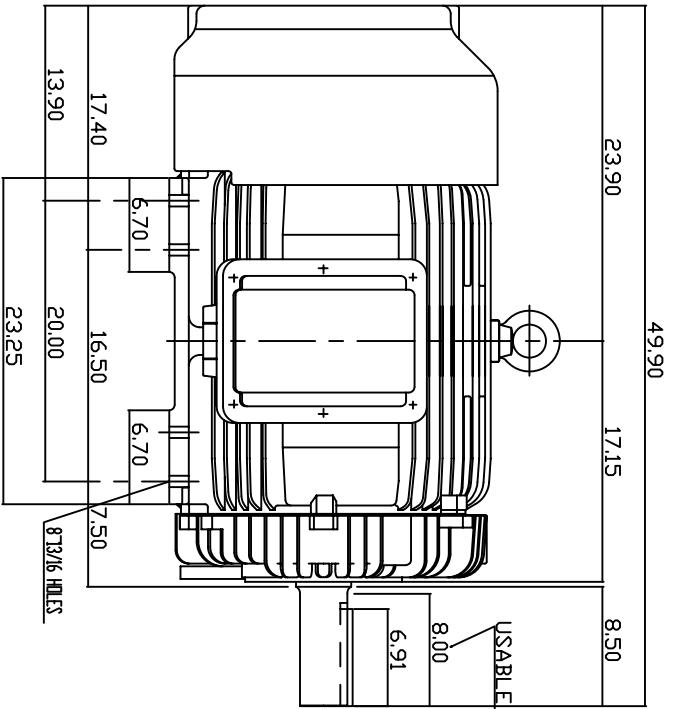

NOTE:

1. DIMENSIONS IN INCH
2. FRAME NO. 447T
3. F CLASS INSULATION, S.F.115
4. FOR DIRECT FLEXIBLE COUPLING
5. ENCLOSURE: IP54
6. BEARING SIZE: DRIVE END: 6320
NON-DRIVE END: 6316
7. APPROX. WEIGHT: 2450 LBS

TW-56C

DWN.	IN QIN	JAN 13 2005
CHKD.	H.HUANG	JAN 13 2005
APPD.	C.WANG	JAN 13 2005

DATE 20050617
CAT. # EP1506-50
3-PHASE INDUCTION MOTOR



DWG NO. 3A040Y597
REV: 00